

GRAN MILANO 440/2016

Ed. 06-2016

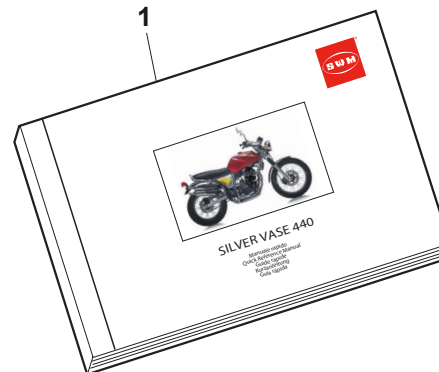

Catalogo ricambi
Spare parts catalog
Catalogue pieces de rechange
Ersatzteilkatalog
Catalogo piezas de repuestos

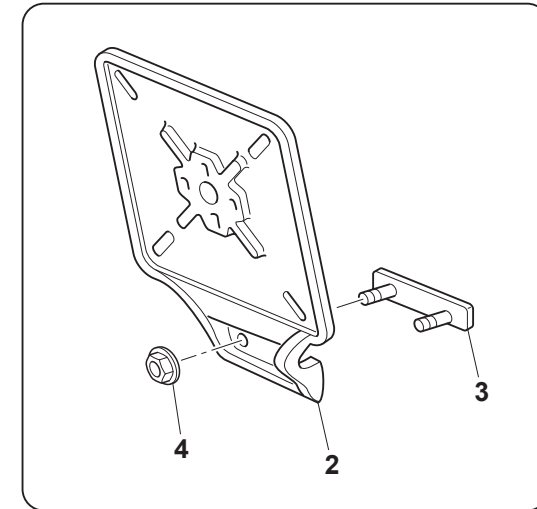
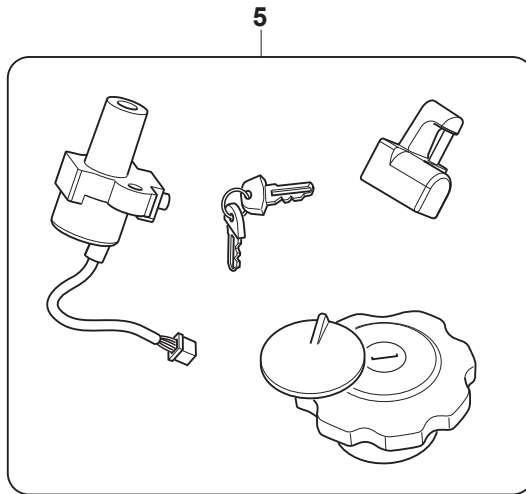

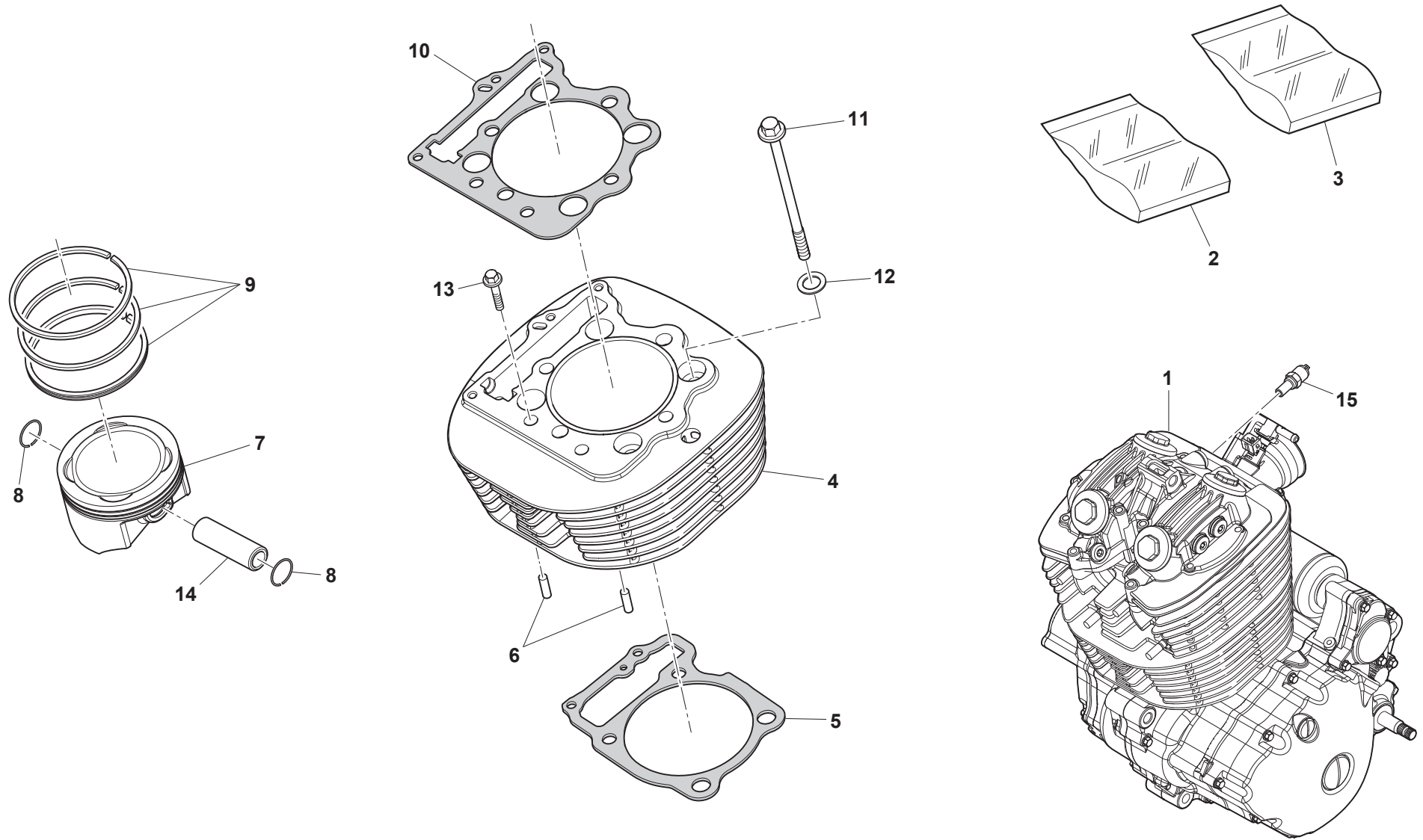



GRAN MILANO 440

CILINDRO, PISTONE - CYLINDER, PISTON CYLINDRE, PISTON - ZYLINDER, KOLBEN CILINDRO, PISTON

TAVOLA
DRAWING
TABLE
BILD
TABLA

2

Note Notes Notes Marke Notas	Pos. No. Index Pos.	N. Cod. Code No. Nr. Code Code Nr N. Cod.	Q.tà Q.ty Q.te M.ge C.ad	DENOMINAZIONE	NAME	DESIGNATION	BESHREIBUNG	DENOMINACION
	1	M000A00897	1	MOTORE COMPLETO	COMPLETE ENGINE	MOTEUR COMPLET	MOTOR KOMPLETT	MOTOR COMPLETO
	2	M000A00927	1	KIT GUARNIZIONI MOTORE	ENGINE GASKET KIT	KIT JOINTS MOTEUR	SATZ MOTORDICHTUNGEN	KIT JUNTAS MOTOR
	3	M000A00928	1	KIT ANELLI DI TENUTA MOTORE	ENGINE SEALING RING KIT	KIT BAGUES D'ETANCHEITE MOTEUR	SATZ DICHTUNGSRINGE MOTOR	KIT ANILLOS DE ESTANQUEIDAD MOTOR
	4	27010699	1	CILINDRO MOTORE	CYLINDER	CYLINDRE	ZYLINDER	CILINDRO
	5	72130598	1	GUARNIZIONE CILINDRO	CYLINDER GASKET	JOINT CYLINDRE	ZYLINDERDICHTUNG	JUNTA CILINDRO
	6	72060091	2	BUSSOLA DI CENTRAGGIO Ø10.5x12x20	BUSH Ø10.5x12x20	DOUILLE Ø10.5x12x20	BUCHSE Ø10.5x12x20	CASQUILLO Ø10.5x12x20
	7	M000A00860	1	ASSIEME PISTONE COMPLETO	COMPLETE PISTON ASSY	PISTON COMPLET	ZUSAMMENBAU KOLBEN KOMPLETT	CONJUNTO PISTÓN COMPLETO
	8	72080065	2	ANELLO RITEGNO SPINOTTO	PISTON PIN RETAINING RING	BAGUE DE RETENUE GOUJON	RÜCKHALTERING KOLBENBOLZEN	ANILLO DE RETENCIÓN EJE DE PISTÓN
	9	21030595	1	KIT SEGMENTI PISTONE	PISTON RING KIT	KIT SEGMENTS PISTON	SATZ KOLBENRINGE	KIT SEGMENTOS PISTÓN
	10	72130590	1	GUARNIZIONE TESTA MOTORE	ENGINE HEAD GASKET	JOINT	DICHTUNG	JUNTA
	11	72011371	4	VITE CILINDRO M10x100	SCREW M10x100	VIS M10x100	SCHRAUBE M10x100	TORNILLO M10x100
	12	72040577	4	ROSETTA Ø10,8x18,6x2	WASHER Ø10,8x18,6x2	RONDELLE Ø10,8x18,6x2	UNTERLEGSCHEIBE Ø10,8x18,6x2	ARANDELA Ø10,8x18,6x2
	13	72010388	2	VITE M6x32	BOLT M6x32	VIS M6x32	SCHRAUBE M6x32	TORNILLO M6x32
	14	21040044	1	SPINOTTO	PISTON PIN	GOUJON	KOLBENBOLZEN	EJE DE PISTON
	15	31350056	1	SENSORE TEMPERATURA	TEMPERATURE SENSOR	CAPTEUR DE TEMPÉRATURE	TEMPERATURSENSOR	SENSOR TEMPERATURA

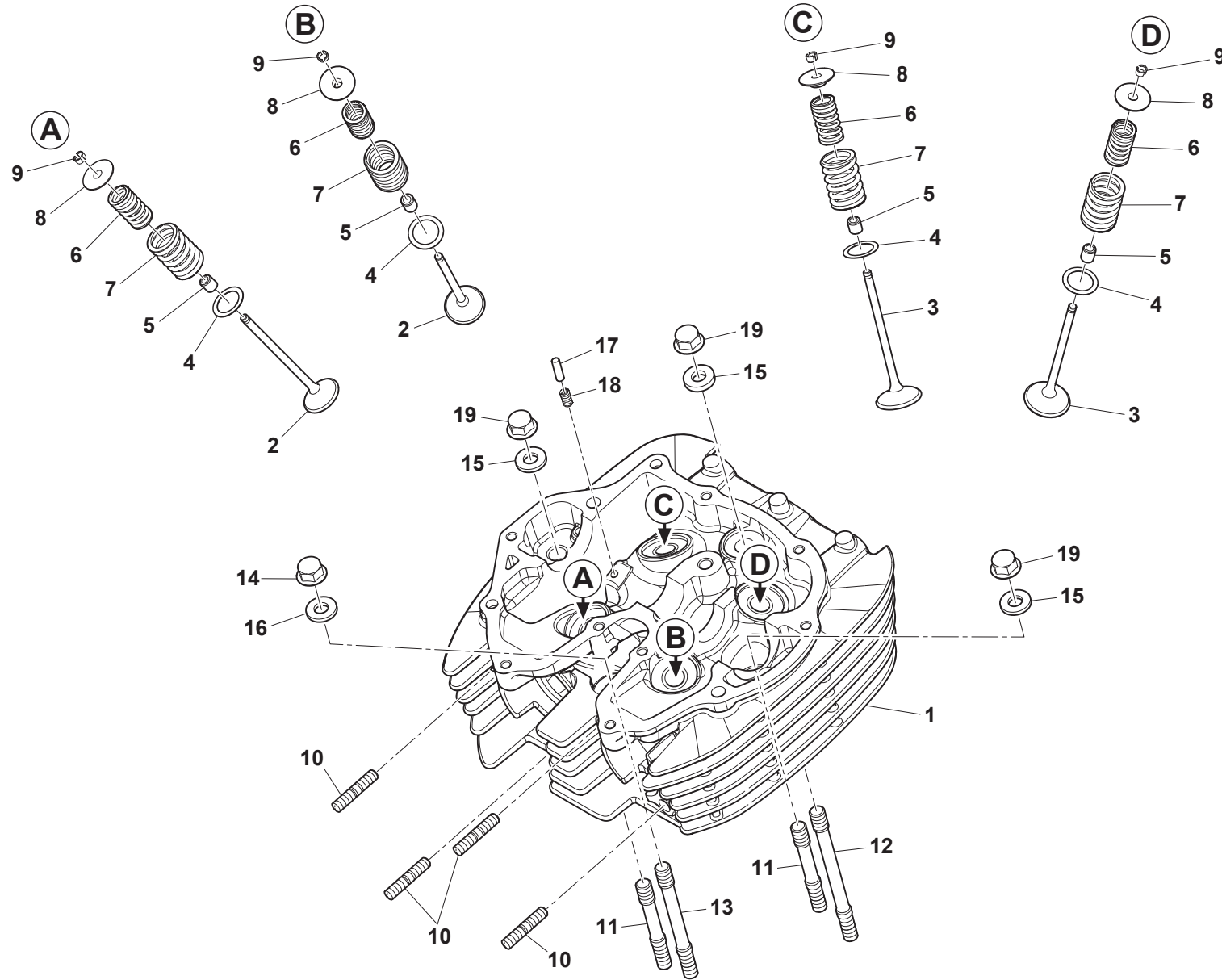



GRAN MILANO 440

**TESTA CILINDRO - CYLINDER HEAD
CULASSE - ZYLINDERKOPF
CULATA**

TAVOLA
DRAWING
TABLE
BILD
TABLA

3

Note Notes Marke Notas	Pos. No. Index Pos.	N. Cod. Code No. Nr. Code Code Nr N. Cod.	Q.tà Q.ty Q.te M.ge C.ad	DENOMINAZIONE	NAME	DESIGNATION	BESHREIBUNG	DENOMINACION
	1	22011001	1	TESTA MOTORE COMPLETA	ENGINE HEAD ASSY	CULASSE COMPLETE	MOTORKOPF KOMPLETT	CULATA COMPLETA
	2	22020044	2	VALVOLA DI SCARICO	EXHAUST VALVE	SOUPAPE D'ECHAPPEMENT	AUSLASSVENTIL	VÁLVULA DE ESCAPE
	3	22020043	2	VALVOLA DI ASPIRAZIONE	INTAKE VALVE	SOUPAPE D'ADMISSION	EINLASSVENTIL	VÁLVULA DE ADMISIÓN
	4	72040365	4	ROSETTA PER MOLLA Ø18.7x26.3x1	OUTER SPRING WASHER 18.7x26.3x1	RONDELLE Ø18.7x26.3x1	UNTERLEGSCHEIBE Ø18.7x26.3x1	ARANDELA Ø18.7x26.3x1
	5	72110026	4	TENUTA VALVOLE	VALVE SEALING	D'ETANCHEITE SOUPAPES	VENTILDICHTUNGS	ESTANQUEIDAD VALVULAS Ø5
	6	72120082	4	MOLLA INTERNA VALVOLA	INTERNAL VALVE SPRING	RESSORT INTERIEUR	INTERNE FEDER	MUELLE INTERNO
	7	72120083	4	MOLLA ESTERNA VALVOLA	EXTERNAL VALVE SPRING	RESSORT EXTERIEUR	EXTERNE FEDER	MUELLE EXTERNO
	8	22030003	4	SCODELLINO	RETAINER	RONDELLE À RESSORT	FEDERTELLER	ASIEN TO
	9	22040003	4	SEMICONO	COLLET	DEMI-CONE	KEGELHÄLFTE	SEMICONO
	10	72011809	4	VITE M8x41	BOLT M8x41	VIS M8x41	SCHRAUBE M8x41	TORNILLO M8x41
	11	72011372	2	PRIGIONIERO M10x86	STUD BOLT M10x86	PRISONNIER M10x86	STIFTSCHRAUBE M10x86	PRISIONERO M10x86
	12	72011373	1	PRIGIONIERO M10x118	STUD BOLT M10x118	PRISONNIER M10x118	STIFTSCHRAUBE M10x118	PRISIONERO M10x118
	13	72011376	1	PRIGIONIERO M10x99	STUD BOLT M10x99	PRISONNIER M10x99	STIFTSCHRAUBE M10x99	PRISIONERO M10x99
	14	72020359	1	TAPPO A VITE M10x1.25	CAP NUT M10x1.25	BOUCHON M10x1.25	STOPFEN M10x1.25	TAPON M10x1.25
	15	72040369	3	ROSETTA Ø10.3x20.8x3	WASHER Ø10.3x20.8x3	RONDELLE Ø10.3x20.8x3	UNTERLEGSCHEIBE Ø10.3x20.8x3	ARANDELA Ø10.3x20.8x3
	16	72040370	1	ROSETTA Ø10.3x25x4	WASHER Ø10.3x25x4	RONDELLE Ø10.3x25x4	UNTERLEGSCHEIBE Ø10.3x25x4	ARANDELA Ø10.3x25x4
	17	72060088	1	PERNO	PIN	AXE	BOLZEN	EJE
	18	72120086	1	MOLLA LEVA DECOMPRESSORE	DECOMPRESSION LEVER SPRING	RESSORT	FEDER	MUELLE
	19	72020024	3	TAPPO A VITE M10 x 1,25	CAP NUT M10 x 1,25	BOUCHON M10 x 1,25	DECKEL M10 x 1,25	TAPON M10 x 1,25

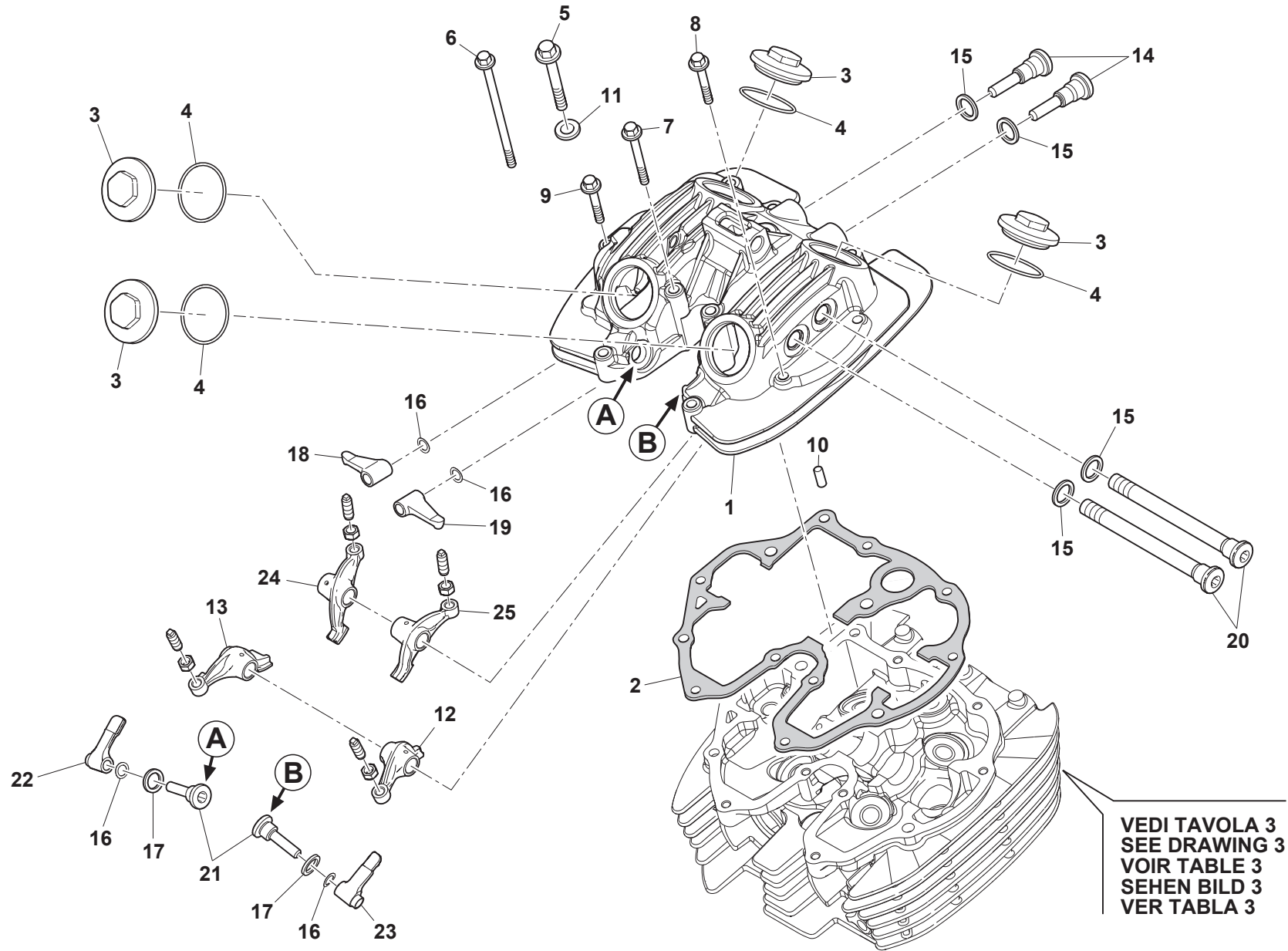



GRAN MILANO 440

**COPERCHIO VALVOLE - VALVE COVER
COUVERCLE CULASSE - ZYLINDERKOPFDECKEL
TAPA CULATA**

TAVOLA
DRAWING
TABLE
BILD
TABLA

4

Note Notes Marke Notas	Pos. No. N. Index Pos.	N. Cod. Code No. Nr. Code Code Nr N. Cod.	Q.tà Q.ty Q.te M.ge C.ad	DENOMINAZIONE	NAME	DESIGNATION	BESHREIBUNG	DENOMINACION
	1	22150272	1	COPERCHIO TESTA MOTORE	CYLINDER HEAD COVER	COUVERCLE CULASSE	ZYLINDERKOPFDECKEL	TAPA CULATA
	2	72130392	1	GUARNIZIONE COPERCHIO TESTA	HEAD COVER GASKET	JOINT COUVERCLE CULASSE	DICHTUNG ZYLINDERKOPFDECKEL	JUNTA TAPA CULATA
	3	22140006	4	TAPPO VALVOLA	VALVE PLUG	BOUCHON	STOPFEN	TAPON
	4	72150013	4	ANELLO OR	O-RING	JOINT TORIQUE	O-RING	JUNTA TORICA
	5	72011374	1	VITE M8x70	BOLT M8x70	VIS M8x70	SCHRAUBE M8x70	TORNILLO M8x70
	6	72011917	3	VITE M6x119	BOLT M6x119	VIS M6x119	SCHRAUBE M6x119	TORNILLO M6x119
	7	72010392	2	VITE M6x65	BOLT M6x65	VIS M6x65	SCHRAUBE M6x65	TORNILLO M6x65
	8	72010389	1	VITE M6x40	BOLT M6x40	VIS M6x40	SCHRAUBE M6x40	TORNILLO M6x40
	9	72010169	6	VITE M6x35	BOLT M6x35	VIS M6x35	SCHRAUBE M6x35	TORNILLO M6x35
	10	72060012	2	SPINA Ø8x14	DOWEL PIN Ø8x14	GOUPILLE Ø8x14	STIFT Ø8x14	CLAVIJA Ø8x14
	11	72040156	1	ROSETTA IN RAME Ø8.5x18x2	COPPER WASHER Ø8.5x18x2	RONDELLE Ø8.5x18x2	UNTERLEGSCHEIBE Ø8.5x18x2	ARANDELA Ø8.5x18x2
	12	22050019	1	BILANCIERE	ROCKER ARM	CULBUTEUR	UMLENK-HEBEL	BALANCÍN
	13	22050020	1	BILANCIERE	ROCKER ARM	CULBUTEUR	UMLENK-HEBEL	BALANCÍN
	14	22070014	2	ALBERO BILANCIERE	ROCKER ARM SHAFT	ARBRE	WELLE	ARBOL
	15	72040364	4	ROSETTA IN RAME Ø14.2x20x1.5	COPPER WASHER Ø14.2x20x1.5	RONDELLE Ø14.2x20x1.5	UNTERLEGSCHEIBE Ø14.2x20x1.5	ARANDELA Ø14.2x20x1.5
	16	73131480	4	ROSETTA Ø8.2x12x0.3	WASHER Ø8.2x12x0.3	RONDELLE Ø8.2x12x0.3	UNTERLEGSCHEIBE Ø8.2x12x0.3	ARANDELA Ø8.2x12x0.3
	17	72040363	2	ROSETTA IN RAME Ø12.2x18.5x2	COPPER WASHER Ø12.2x18.5x2	RONDELLE Ø12.2x18.5x2	UNTERLEGSCHEIBE Ø12.2x18.5x2	ARANDELA Ø12.2x18.5x2
	18	22050018	1	BILANCIERE	ROCKER ARM	CULBUTEUR	UMLENK-HEBEL	BALANCÍN
	19	22050018	1	BILANCIERE	ROCKER ARM	CULBUTEUR	UMLENK-HEBEL	BALANCÍN
	20	22070015	2	ALBERO PRINCIPALE BILANCIERE M14x1.5	MAIN ROCKER ARM SHAFT M14x1.5	ARBRE M14x1.5	WELLE M14x1.5	ARBOL M14x1.5
	21	22070013	2	ALBERO BILANCIERE	ROCKER ARM SHAFT	ARBRE	WELLE	ARBOL
	22	22050016	1	BILANCIERE SINISTRO	ROCKER ARM L.H.	CULBUTEUR G.	UMLENK-HEBEL L.	BALANCÍN IZQ.
	23	22050017	1	BILANCIERE DESTRO	ROCKER ARM R.H.	CULBUTEUR D.	UMLENK-HEBEL R.	BALANCÍN DER.
	24	22050019	2	BILANCIERE	ROCKER ARM	CULBUTEUR	UMLENK-HEBEL	BALANCÍN
	25	22050020	1	BILANCIERE	ROCKER ARM	CULBUTEUR	UMLENK-HEBEL	BALANCÍN

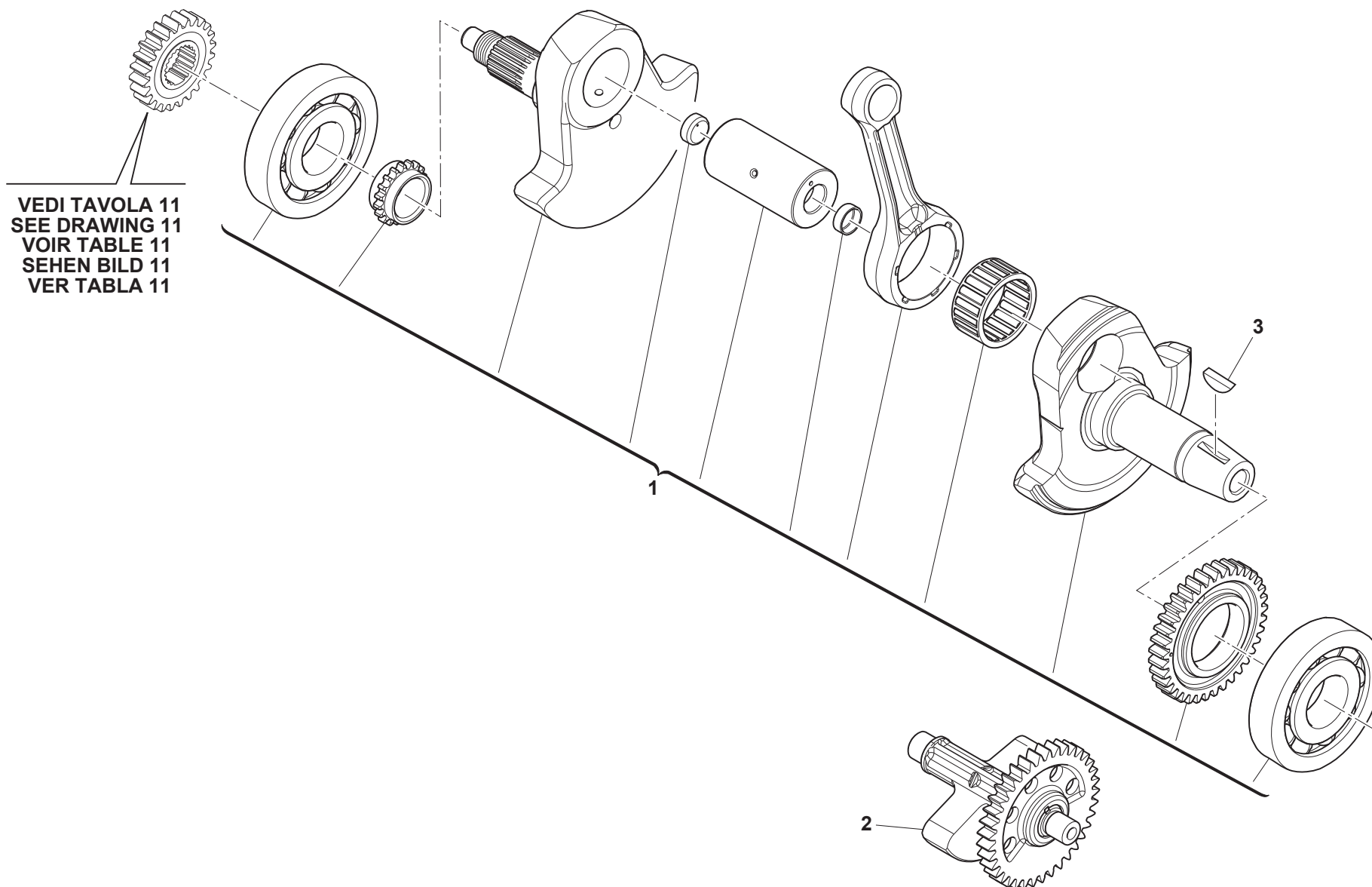

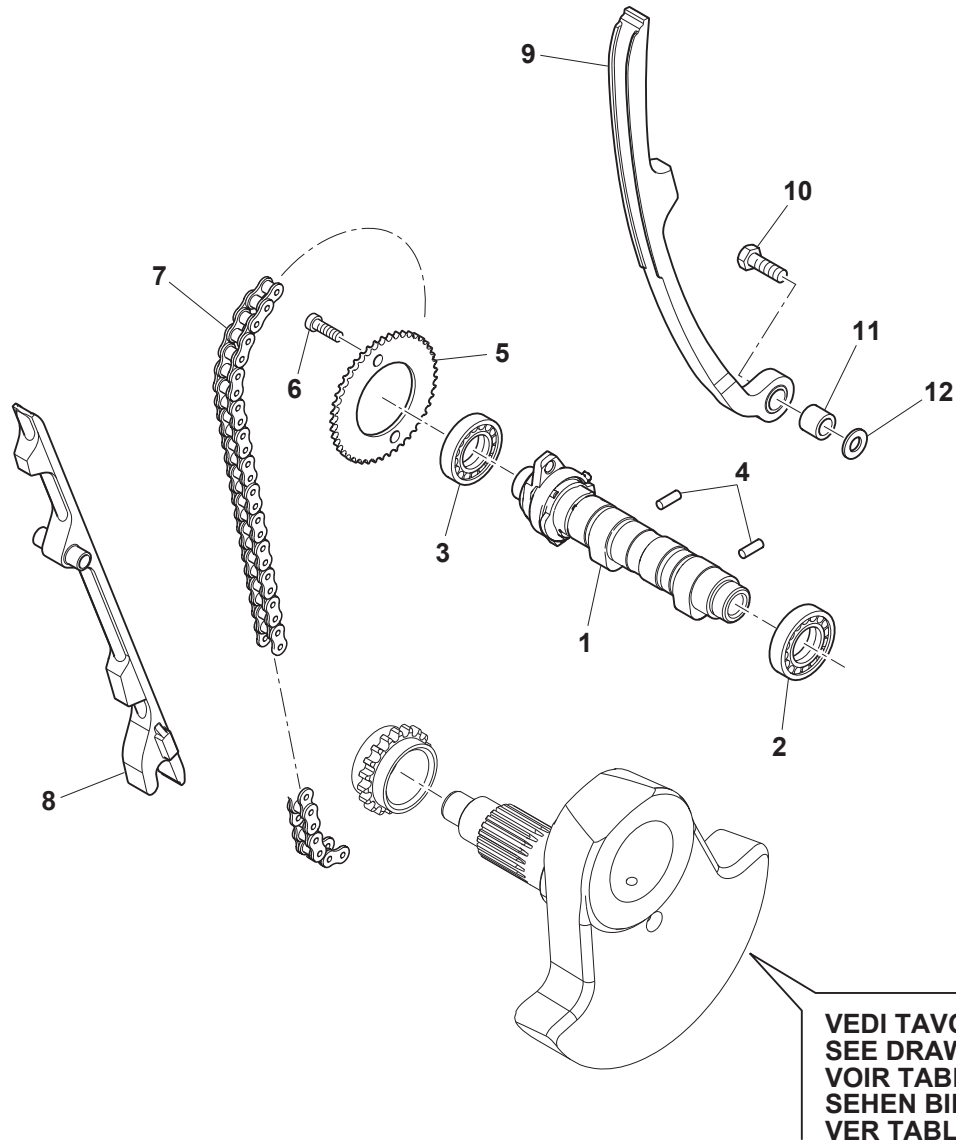

VEDI TAVOLA 2
SEE DRAWING 2
VOIR TABLE 2
SEHEN BILD 2
VER TABLA 2

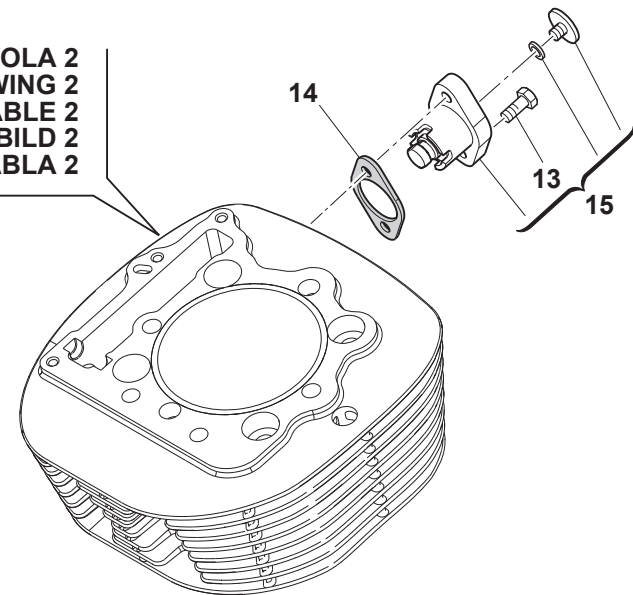



Note Notes Marke Notas	Pos. No. Index Pos.	N. Cod. Code No. Nr. Code Code Nr N. Cod.	Q.tà Q.ty M.ge C.ad	DENOMINAZIONE	NAME	DESIGNATION	BESHREIBUNG	DENOMINACION
	1	22080029	1	ASSIEME ALBERO A CAMME	CAMSHAFT	ARBRE A CAMES	NOCKENWELLE	ARBOL DE LEVAS
	2	70090199	1	CUSCINETTO Ø20x37x9	BEARING Ø20x37x9	ROULEMENT Ø20x37x9	LAGER Ø20x37x9	COJINETE Ø20x37x9
	3	70090198	1	CUSCINETTO Ø18x37x9	BEARING Ø18x37x9	ROULEMENT Ø18x37x9	LAGER Ø18x37x9	COJINETE Ø18x37x9
	4	72060090	2	PERNO 10x18	PIN 10x18	AXE 10x18	BOLZEN 10x18	EJE 10x18
	5	15170067	1	INGRANAGGIO DISTRIBUZIONE	TIMING DRIVEN SPROCKET	PIGNON DE DISTRIBUTION	ZAHNRAD	ENGRANAJE DISTRIBUCIÓN
	6	72011369	2	VITE TE M7x9.4	HEXAGON SOCKET-HEAD BOLT M7x9.4	VIS M7x9.4	SCHRAUBE M7x9.4	TORNILLO M7x9.4
	7	15160015	1	CATENA DISTRIBUZIONE	TIMING CHAIN	CHAINE DE DISTRIBUTION	VENTILSTEUERKETTE	CADENA DISTRIBUCION
	8	73011167	1	PATTINO CATENA	CHAIN SLIDER	PATIN CHAÎNE	KETTENSANNERAUFLAGE	PATÍN CADENA
	9	73011166	1	PIASTRA TENDICATENA	CHAIN SLIDER PLATE	PLAQUE	PLATTE	PLACA
	10	72010163	1	VITE M6x25	BOLT M6x25	VIS M6x25	SCHRAUBE M6x25	TORNILLO M6x25
	11	72060089	1	BUSSOLA PIASTRA TENDICATENA	BUSH	DOUILLE	BUCHSE	CASQUILLO
	12	72040167	1	ROSETTA Ø6.5x14.2x1	WASHER Ø6.5x14.2x1	RONDELLE Ø6.5x14.2x1	UNTERLEGSscheibe Ø6.5x14.2x1	ARANDELA Ø6.5x14.2x1
	13	72010157	2	VITE M6x16	SCREW M6x16	VIS M6x16	SCHRAUBE M6x16	TORNILLO M6x16
	14	72130438	1	GUARNIZIONE TENDICATENA	TENSIONER GASKET	JOINT	DICHTUNG	JUNTA
	15	15150022	1	TENDICATENA	CHAIN TENSIONER	TENDEUR DE CHAÎNE	KETTENSANNER	SENSOR DE CADENA

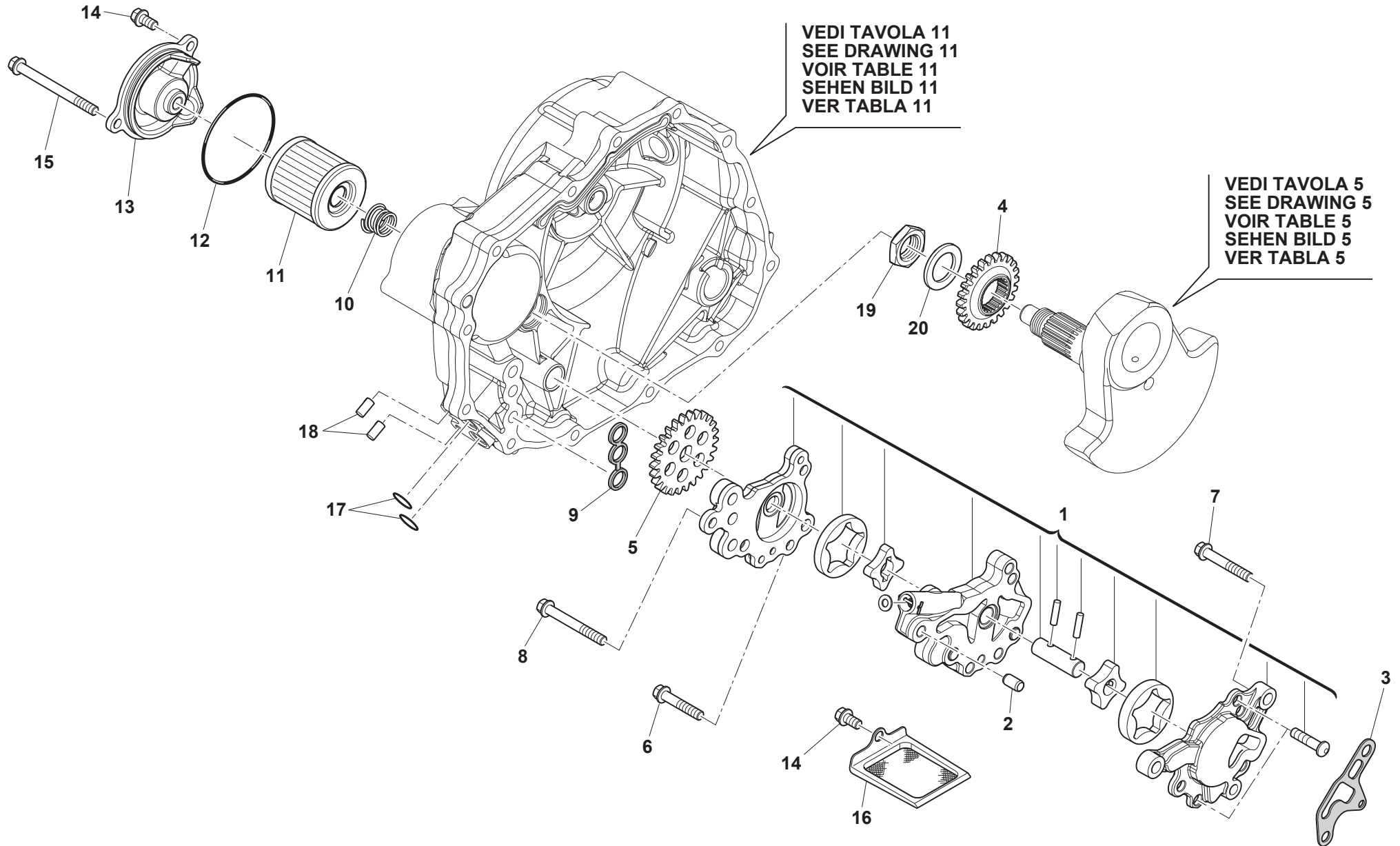



Note Notes Marka Notas	Pos. N. Index Pos.	N. Cod. Code No. Nr. Code Code Nr N. Cod.	Q.tà Q.ty Q.te M.ge C.ad	DENOMINAZIONE	NAME	DESIGNATION	BESHREIBUNG	DENOMINACION
	1	20010077	1	POMPA OLIO COMPLETA	COMPLETE OIL PUMP	POMPE A HUILE COMPLETE	ÖLPUMPE KOMPLETT	BOMBA ACEITE COMPLETA
	2	72060012	2	BUSSOLA Ø10x14	BUSHING Ø10x14	DOUILLE Ø10x14	BUCHSE Ø10x14	CASQUILLO Ø10x14
	3	72130423	1	GUARNIZIONE POMPA OLIO	OIL PUMP GASKET	JOINT POMPE A HUILE	DICHTUNG ÖLPUMPE	JUNTA BOMBA ACEITE
	4	20060005	1	INGRANAGGIO CONDUTTORE POMPA OLIO	DRIVE GEAR, OIL PUMP	ENGRENAGE CONDUCTEUR	ANTRIEBSZAHNRAD	ENGRANAJE CONDUCTOR
	5	20060006	1	INGRANAGGIO POMPA OLIO	OIL PUMP GEAR	ENGRENAGE POMPE	PUMPENZAHNRAD	ENGRANAJE BOMBA
	6	72010388	1	VITE M6x32	BOLT M6x32	VIS M6x32	SCHRAUBE M6x32	TORNILLO M6x32
	7	72010389	1	VITE M6x40	BOLT M6x40	VIS M6x40	SCHRAUBE M6x40	TORNILLO M6x40
	8	72010173	1	VITE M6x50	BOLT M6x50	VIS M6x50	SCHRAUBE M6x50	TORNILLO M6x50
	9	72150127	1	ANELLO IN GOMMA A 3 FORI	RING	BAGUE	RING	ANILLO
	10	72120159	1	MOLLA	SPRING	RESSORT	FEDER	MUELLE
	11	8000B0593	1	FILTRO OLIO	OIL FILTER	FILTRE À HUILE	ÖLFILTER	FILTRO ACEITE
	12	72150220	1	ANELLO OR	O-RING	JOINT TORIQUE	O-RING	JUNTA TORICA
	13	14090073	1	COPERCHIO FILTRO OLIO	OIL FILTER COVER	COUVERCLE	DECKEL	TAPA
	14	72010157	2	VITE M6x16	BOLT M6x16	VIS M6x16	SCHRAUBE M6x16	TORNILLO M6x16
	15	72010394	1	VITE M6x90	BOLT M6x90	VIS M6x90	SCHRAUBE M6x90	TORNILLO M6x90
	16	11060005	1	FILTRO A RETE	MESH FILTER	FILTRE À GRILLE	NETZFILTER	FILTRO DE RED
	17	72150213	2	ANELLO OR	O-RING	JOINT TORIQUE	O-RING	JUNTA TORICA
	18	72060019	2	BUSSOLA Ø10x14	DOWEL PIN Ø10x14	DOUILLE Ø10x14	BUCHSE Ø10x14	CASQUILLO Ø10x14
	19	72020360	1	DADO M18x1	NUT M18x1	ECROU M18x1	MUTTER M18x1	TUERCA M18x1
	20	72040367	1	RONDELLA	WASHER	RONDELLE	UNTERLEGSCHNITT	ARANDELA

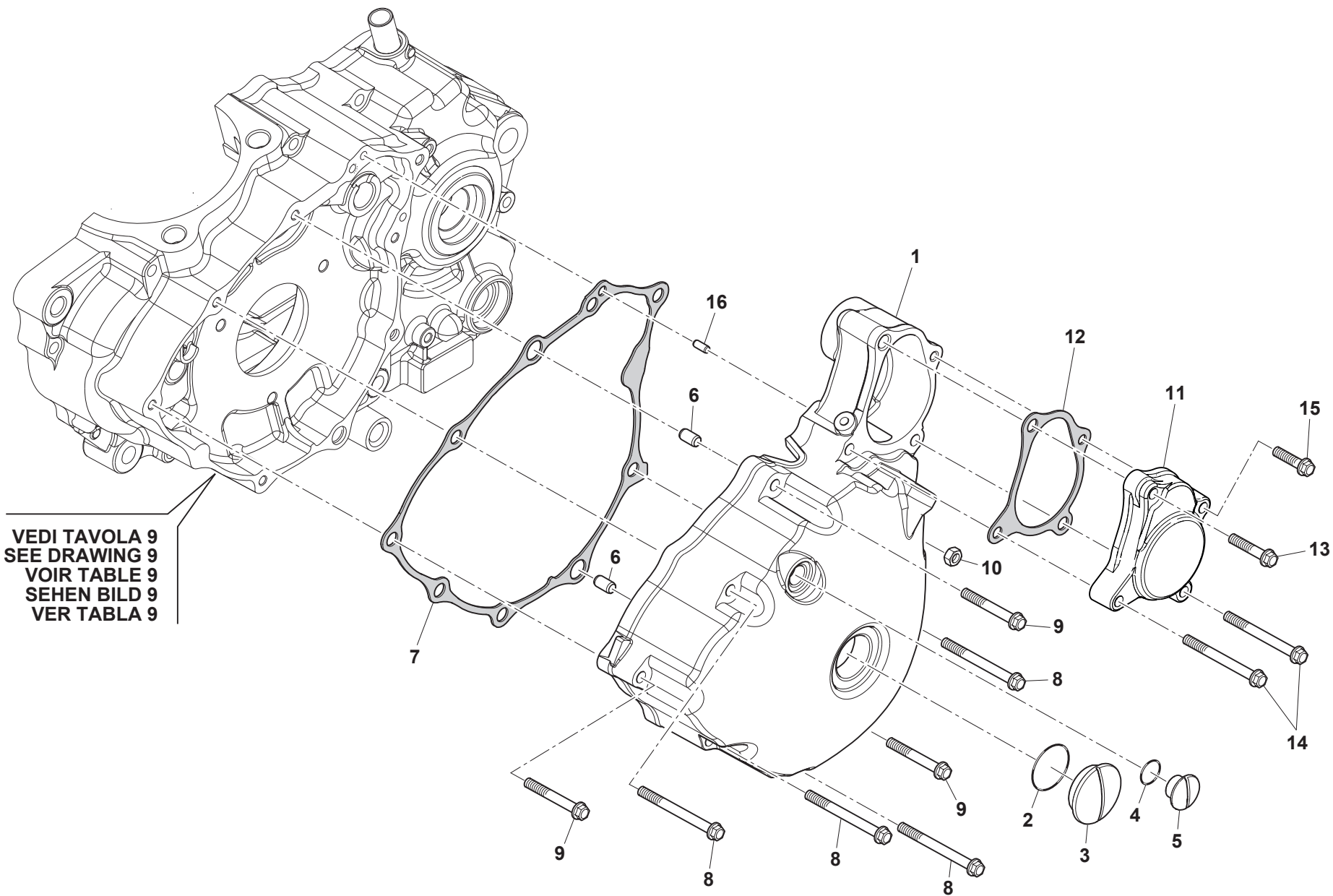

VEDI TAVOLA 9
SEE DRAWING 9
VOIR TABLE 9
SEHEN BILD 9
VER TABLA 9



**COPERCHIO CARTER SINISTRO - LEFT CRANKCASE COVER
COUVERCLES CARTER GAUCHE - GEHAUSEDECKEL LINKS
TAPAS BANCADA IZQUIERDA**

Note Notes Notes Marke Notas	Pos. No. Index Pos.	N. Cod. Code No. Nr. Code Code Nr N. Cod.	Q.tà Q.ty Q.te M.ge C.ad	DENOMINAZIONE	NAME	DESIGNATION	BESHREIBUNG	DENOMINACION
	1	14010970	1	COPERCHIO ACCENSIONE	IGNITION COVER	COUVERCLE ALLUMAGE	DECKEL ZÜNDUNG	TAPA ENCENDIDO
	2	72150009	1	ANELLO OR	O-RING	JOINT TORIQUE	O-RING	JUNTA TORICA
	3	14060063	1	TAPPO GRANDE ISPEZIONE	BIG INSPECTION CAP	BOUCHON GRAND	STOPFEN	TAPON GRANDE
	4	72150021	1	ANELLO OR	O-RING	JOINT TORIQUE	O-RING	JUNTA TORICA
	5	14060064	1	TAPPO PICCOLO ISPEZIONE	SMALL INSPECTION CAP	BOUCHON PETIT	STOPFEN	TAPON
	6	72060014	2	BUSSOLA Ø10x20	DOWEL PIN Ø10x20	DOUILLE Ø10x20	BUCHSE Ø10x20	CASQUILLO Ø10x20
	7	72130595	1	GUARNIZIONE COPERCHIO ACCENSIONE	LEFT CRANKCASE COVER GASKET	JOINT	DICHTUNG	JUNTA
	8	72010174	4	VITE M6x60	BOLT M6x60	VIS M6x60	SCHRAUBE M6x60	TORNILLO M6x60
	9	72010173	2	VITE M6x50	BOLT M6x50	VIS M6x50	SCHRAUBE M6x50	TORNILLO M6x50
	10	72020358	1	DADO M6	NUT M6	ECROU M6	MUTTER M6	TUERCA M6
	11	14070206	1	COPERCHIO AVVIAMENTO	KICK START COVER	COUVERCLE DE DEMARRAGE	DEKEL KICKSTARTER	TAPA ARRANQUE
	12	72130395	1	GUARNIZIONE COPERCHIO AVVIAMENTO	KICK START COVER GASKET	JOINT	DICHTUNG	JUNTA
	13	72010169	1	VITE M6x35	BOLT M6x35	VIS M6x35	SCHRAUBE M6x35	TORNILLO M6x35
	14	72010392	2	VITE M6x65	BOLT M6x65	VIS M6x65	SCHRAUBE M6x65	TORNILLO M6x65
	15	72010387	1	VITE M6x28	BOLT M6x28	VIS M6x28	SCHRAUBE M6x28	TORNILLO M6x28
	16	72060012	2	SPINA Ø8x14	DOWEL Ø8x14	GOUPILLE Ø8x14	STIFT Ø8x14	CLAVIJA Ø8x14

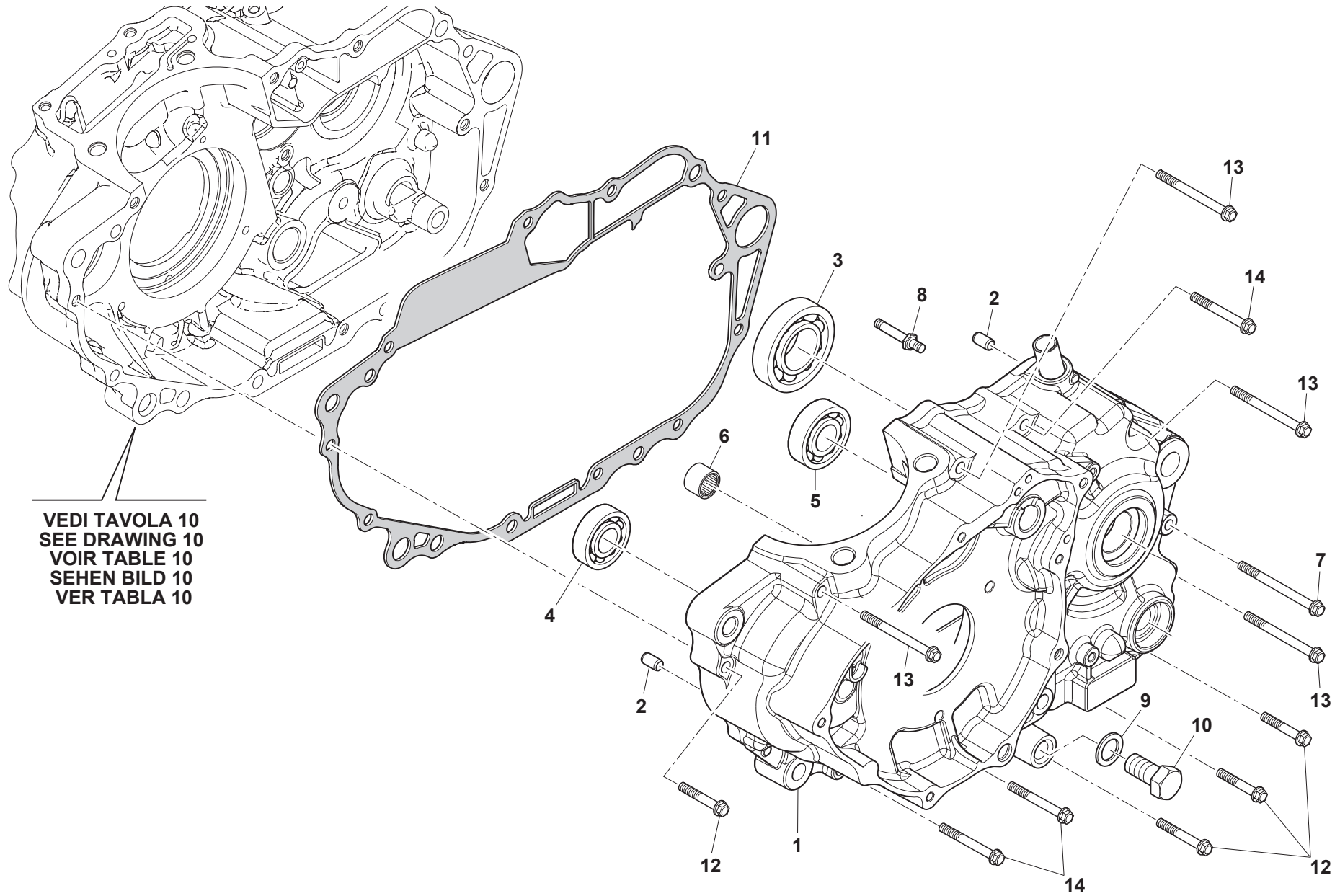

VEDI TAVOLA 10
SEE DRAWING 10
VOIR TABLE 10
SEHEN BILD 10
VER TABLA 10



GRAN MILANO 440

**SEMICARTER SINISTRO - LEFT HALF CRANKCASE
 CARTER GAUCHE - GEHAUSEDECKEL LINKS
 BANCADA IZQUIERDA**

TAVOLA
 DRAWING
 TABLE
 BILD
 TABLA

9

Note Notes Notes Marke Notas	Pos. No. Index Pos.	N. Cod. Code No. Nr. Code Code Nr N. Cod.	Q.tà Q.ty Q.te M.ge C.ad	DENOMINAZIONE	NAME	DESIGNATION	BESHREIBUNG	DENOMINACION
	1	11010664	1	CARTER SINISTRO	LEFT CRANKCASE	CARTER G.	DECKEL R.	CÁRTER DER.
	2	72060019	2	BUSSOLA Ø10x16	DOWEL PIN Ø10x16	DOUILLE Ø10x16	BUCHSE Ø10x16	CASQUILLO Ø10x16
	3	70090194	1	CUSCINETTO 6006	BEARING 6006	ROULEMENT 6006	LAGER 6006	COJINETE 6006
	4	70090193	1	CUSCINETTO 6301/13/C3	BEARING 6301/13/C3	ROULEMENT 6301/13/C3	LAGER 6301/13/C3	COJINETE 6301/13/C3
	5	70090195	1	CUSCINETTO 6203Z	BEARING 6203Z	ROULEMENT 6203Z	LAGER 6203Z	COJINETE 6203Z
	6	70090016	1	CUSCINETTO HK1210	BEARING HK1210	ROULEMENT HK1210	LAGER HK1210	COJINETE HK1210
	7	72010176	1	VITE M6x80	BOLT M6x80	VIS M6x80	SCHRAUBE M6x80	TORNILLO M6x80
	8	72011363	1	VITE M8x41	BOLT M8x41	VIS M8x41	SCHRAUBE M8x41	TORNILLO M8x41
	9	72040159	1	ROSETTA DI TENUTA	ALUMINIUM WASHER	RONDELLE D'ETANCHEITE	DICHTUNGSSCHEIBE	ARANDELA DE ESTANQUEIDAD
	10	72012089	1	VITE SCARICO OLIO	OIL DRAIN BOLT	VIS VIDANGE D'HUILE	ÖLABLASSSCHRAUBE	TORNILLO VACIADO ACEITE
	11	72130390	1	GUARNIZIONE	GASKET	JOINT	DICHTUNG	JUNTA
	12	72010169	4	VITE M6x35	BOLT M6x35	VIS M6x35	SCHRAUBE M6x35	TORNILLO M6x35
	13	72010392	5	VITE M6x65	BOLT M6x65	VIS M6x65	SCHRAUBE M6x65	TORNILLO M6x65
	14	72010173	3	VITE M6x50	BOLT M6x50	VIS M6x50	SCHRAUBE M6x50	TORNILLO M6x50

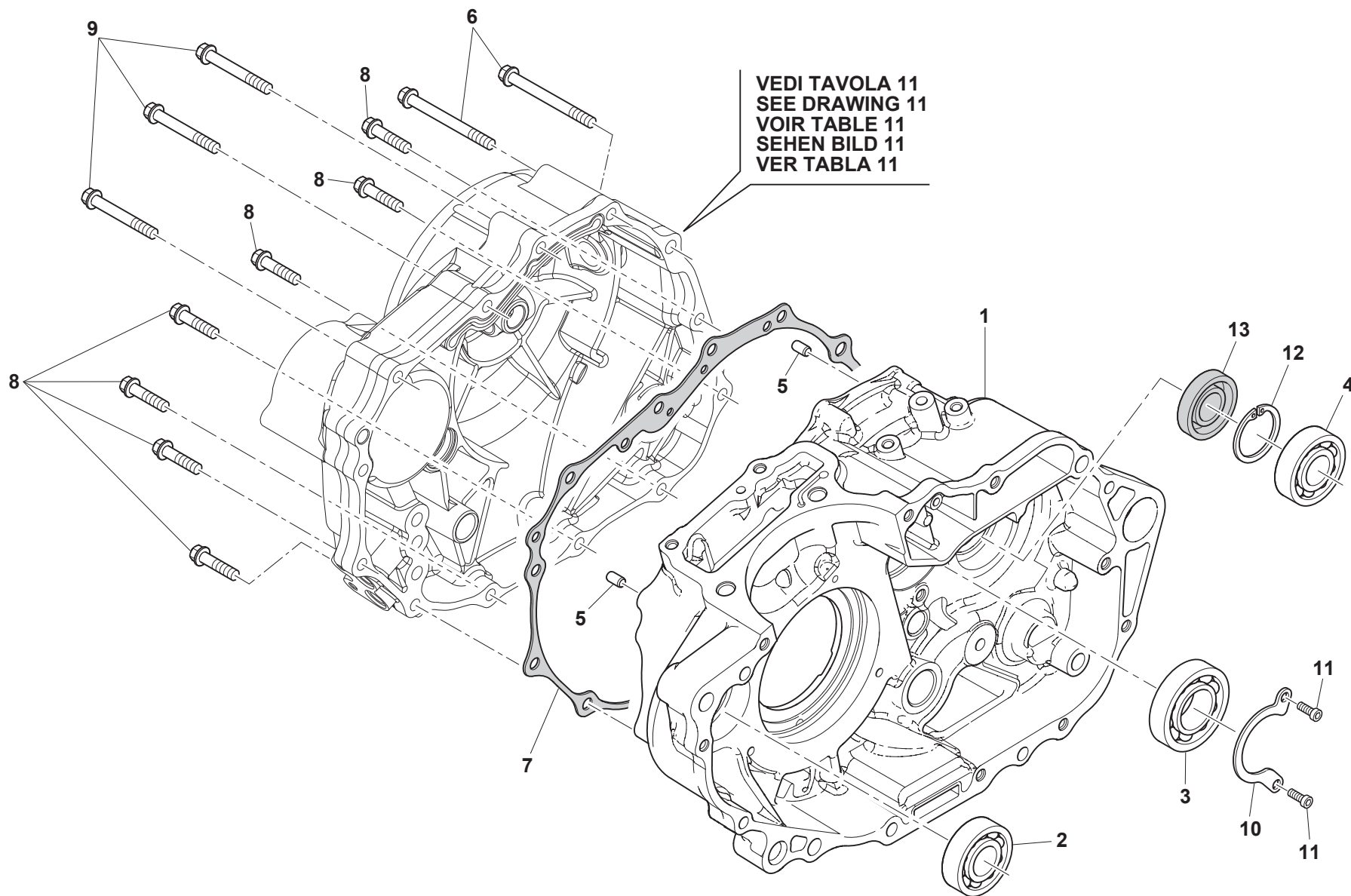



GRAN MILANO 440

SEMICARTER DESTRO - RIGHT HALF CRANKCASE
CARTER DROIT - GEHAUSEDECKEL RECHTS
BANCADA DERECHO

TAVOLA
DRAWING
TABLE
BILD
TABLA

10

Note Notes Notes Marke Notas	Pos. No. Index Pos.	N. Cod. Code No. Nr. Code Code Nr N. Cod.	Q.tà Q.ty Q.te M.ge C.ad	DENOMINAZIONE	NAME	DESIGNATION	BESHREIBUNG	DENOMINACION
	1	12010623	1	CARTER DESTRO	RIGHT CRANKCASE	CARTER D.	GEHAUSE R.	CARTER DER.
	2	70090192	1	CUSCINETTO 6302/C3	BEARING 6302/C3	ROULEMENT 6302/C3	LAGER 6302/C3	COJINETE 6302/C3
	3	70090196	1	CUSCINETTO 62/22	BEARING 62/22	ROULEMENT 62/22	LAGER 62/22	COJINETE 62/22
	4	70090197	1	CUSCINETTO 60/22/18	BEARING 60/22/18	ROULEMENT 60/22/18	LAGER 60/22/18	COJINETE 60/22/18
	5	72060012	2	BUSSOLA Ø10x14	DOWEL PIN Ø10x14	DOUILLE Ø10x14	BUCHSE Ø10x14	CASQUILLO Ø10x14
	6	72010392	2	VITE M6x65	BOLT M6x65	VIS M6x65	SCHRAUBE M6x65	TORNILLO M6x65
	7	72130607	1	GUARNIZIONE COPERCHIO FRIZIONE	GASKET	JOINT	DICHTUNG	JUNTA
	8	72010387	7	VITE M6x28	BOLT M6x28	VIS M6x28	SCHRAUBE M6x28	TORNILLO M6x28
	9	72010390	3	VITE M6x45	BOLT M6x45	VIS M6x45	SCHRAUBE M6x45	TORNILLO M6x45
	10	73131479	1	PIASTRA ALBERO PRIMARIO	PLATE INPUT SHAFT	PLAQUE ARBRE PRIMAIRE	PLATTE	PLACA ARBOL PRIMARIO
	11	72011368	2	VITE	BOLT	VIS	SCHRAUBE	TORNILLO
	12	72080066	1	ANELLO DI TENUTA Ø24x35x5	SEALING RING Ø24x35x5	BAGUE D'ETANCHEITE Ø24x35x5	DICHTUNGSRING Ø24x35x5	ANILLO DE ESTANQUEIDAD Ø24x35x5
	13	72110096	1	ANELLO DI TENUTA Ø18x34x5	SEALING RING Ø18x34x5	BAGUE D'ETANCHEITE Ø18x34x5	DICHTUNGSRING Ø18x34x5	ANILLO DE ESTANQUEIDAD Ø18x34x5

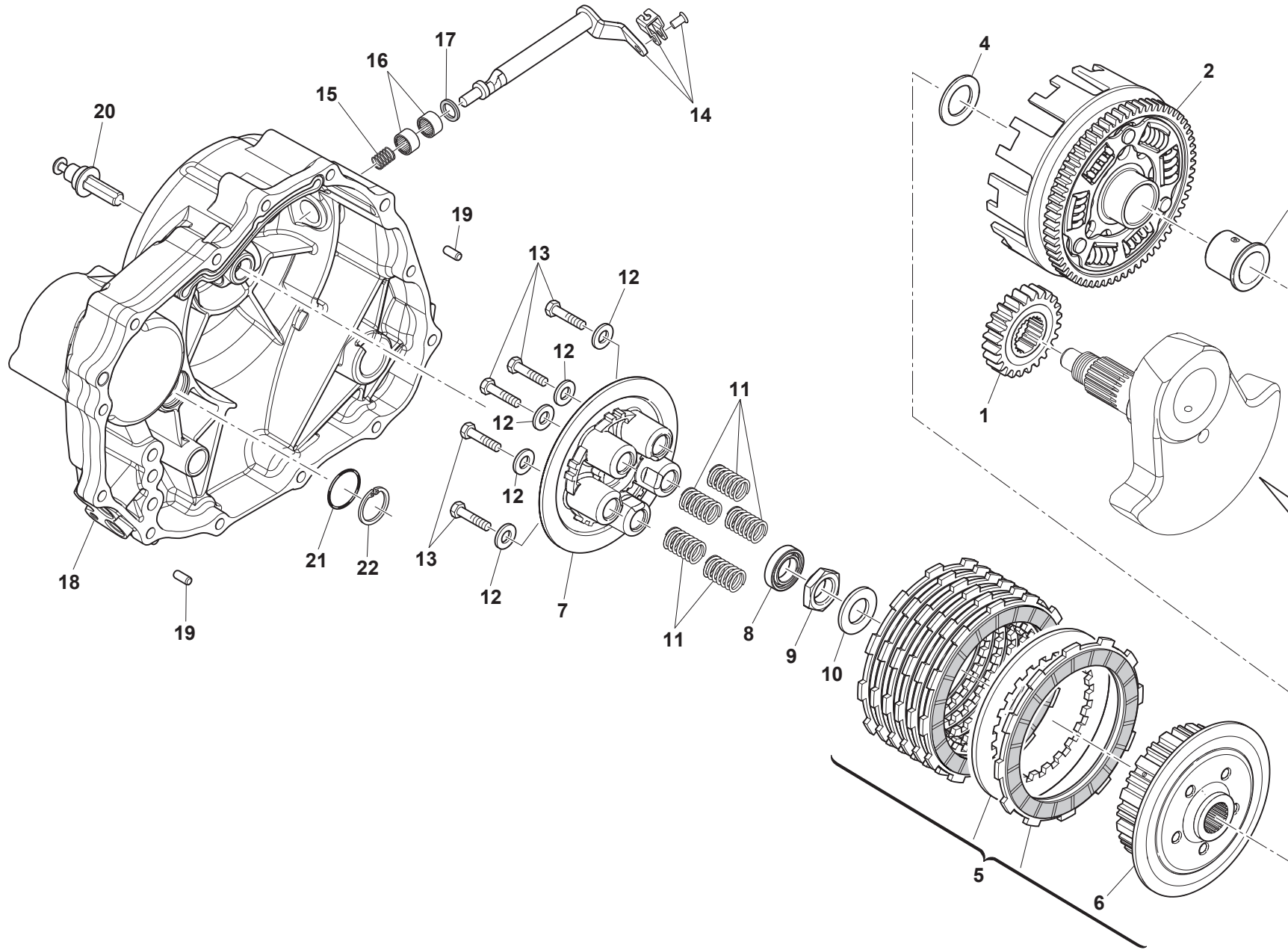

VEDI TAVOLA 5
SEE DRAWING 5
VOIR TABLE 5
SEHEN BILD 5
VER TABLA 5



GRAN MILANO 440

FRIZIONE - CLUTCH EMBRAYAGE - KUPPLUNG EMBRAGUE

TAVOLA
DRAWING
TABLE
BILD
TABLA

11

Note Notes Marke Notas	Pos. No. Index Pos.	N. Cod. Code No. Nr. Code Code Nr N. Cod.	Q.tà Q.ty Q.te M.ge C.ad	DENOMINAZIONE	NAME	DESIGNATION	BESHREIBUNG	DENOMINACION
	1	24020044	1	INGR. CONDUTTORE PRIMARIA	PRIMARY DRIVE GEAR	ENGRENAGE CONDUCTEUR	ANTRIEBSZAHNRAD	ENGRANAJE CONDUCTOR
	2	24120157	1	INGR. CONDOTTO TRASM. PRIMARIA	DRIVEN GEAR, ASSY	ENGRENAGE CONDUIT	ANGETRIEBENES ZAHNRAD	ENGRANAJE CONDICADO
	3	24070261	1	BUSSOLA FRIZIONE Ø22x28x29.3	CLUTCH BUSH Ø22x28x29.3	DOUILLE Ø22x28x29.3	BUCHSE Ø22x28x29.3	CASQUILLO Ø22x28x29.3
	4	24070204	1	ROSETTA Ø22x35x2	WASHER Ø22x35x2	RONDELLE Ø22x35x2	UNTERLEGSCHEIBE Ø22x35x2	ARANDELA Ø22x35x2
	5	24120104	1	MOZZO PORTADISCHI	CLUTCH HUB	MOYEU PORTE-DISQUES	SCHEIBENNABE	CUBO PORTADISCOS
	6	24070251	1	MOZZO	HUB	MOYEU	NABE	CUBO
	7	24070256	1	PIATTO SPINGIDISCO	PUSH DISC PLATE	PLAQUE PRESSE-DISQUE	KUPPLUNGS-DRUCKPLATTE	PLATO PRESION DISCO
	8	24070205	1	CUSCINETTO 61903/P6	BEARING 61903/P6	ROULEMENT 61903/P6	LAGER 61903/P6	COJINETE 61903/P6
	9	24070163	1	DADO M18x1	NUT M18x1	ECROU M18x1	MUTTER M18x1	TUERCA M18x1
	10	72040222	1	RONDELLA	WASHER	RONDELLE	UNTERLEGSCHEIBE	ARANDELA
	11	24070255	5	MOLLA PER FRIZIONE	CLUTCH SPRING	RESSORT POUR EMBRAYAGE	KUPPLUNGSFEDER	MUELLE PARA EMBRAGUE
	12	72040197	5	ROSETTA	WASHER	RONDELLE	UNTERLEGSCHEIBE	ARANDELA
	13	72010097	5	VITE M6x35	SCREW M6x35	VIS M6x35	SCHRAUBE M6x35	TORNILLO M6x35
	14	24030031	1	LEVA DISINNESTO FRIZIONE	CLUTCH PUSH LEVER	LEVIER DEBRAYAGE	KUPPLUNGS-AUSRÜCKSTANGE	PALANCA DESACOPL.EMBRAGUE
	15	72120084	1	MOLLA LEVA DISINNESTO FRIZIONE	CLUTCH CONTROL ROD SPRING	RESSORT	FEDER	MUELLE
	16	70090016	2	CUSCINETTO HK1210	ROLLING NEEDLE HK1210	ROULEMENT HK1210	LAGER HK1210	COJINETE HK1210
	17	72110098	1	GUARNIZIONE	GASKET	JOINT	DICHTUNG	JUNTA
	18	13011908	1	COPERCHIO FRIZIONE	CLUTCH COVER	COUVERCLE D'EMBRAYAGE	KUPPLUNGSDECKEL	TAPA EMBRAGUE
	19	72060012	2	BUSSOLA Ø10x14	BUSHING Ø10x14	DOUILLE Ø10x14	BUCHSE Ø10x14	CASQUILLO Ø10x14
	20	24070295	1	ASTA DISINNESTO FRIZIONE	CLUTCH PUSHROD	TIGE DEBRAYAGE	KUPPLUNGS-AUSRÜCKSTANGE	VARILLA DESACOPLAMIENTO EMBRAGUE
	21	72110097	1	ANELLO DI TENUTA Ø14x22x5	SEALING RING Ø14x22x5	BAGUE D'ETANCHEITE Ø14x22x5	DICHTUNGSRING Ø14x22x5	ANILLO DE ESTANQUEIDAD Ø14x22x5
	22	72080066	1	ANELLO DI FERMO INTERNO	INNER RETAINING RING	BAGUE D'ARRET	SICHERUNGSRING	ANILLO DE RETENCION

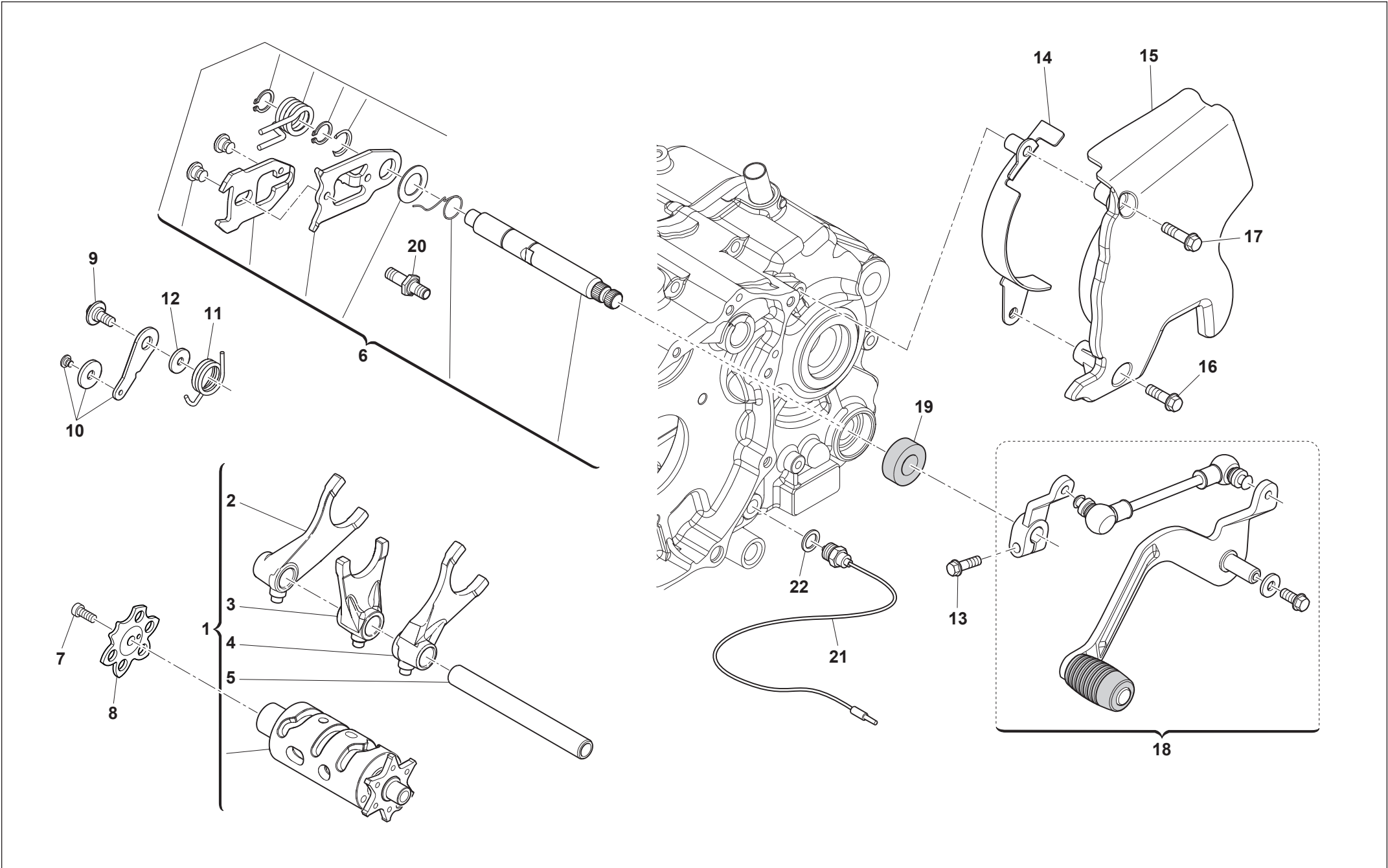



GRAN MILANO 440

COMANDO CAMBIO - GEARSHIFT MECHANISM COMMANDE DE VITESSE - GANGSCHALTUNG MANDO CAMBIO

TAVOLA
DRAWING
TABLE
BILD
TABLA

12

Note Notes Marke Notas	Pos. No. N. Index Pos.	N. Cod. Code No. Nr. Code Code Nr N. Cod.	Q.tà Q.ty Q.te M.ge C.ad	DENOMINAZIONE	NAME	DESIGNATION	BESHREIBUNG	DENOMINACION
	1	15050043	1	ASS. TAMBURIO SELETTORE MARCE	GEAR SELECTOR DRUM, ASSY	TAMBOUR SELECTEUR DE VITESSES COMPL	.SCHALTWALZE	TAMBOR SELECTOR MARCHAS
	2	15140017	1	FORCELLA CAMBIO (1ª)	GEARBOX FORK (1ST)	FOURCHE BOÎTE DE VITESSES (1ERE)	SCHALTGABEL 1.	HORQUILLA CAMBIO (1ª)
	3	15140018	1	FORCELLA CAMBIO (2ª)	GEARBOX FORK (2ND)	FOURCHE BOÎTE DE VITESSES (2EME)	SCHALTGABEL 2.	HORQUILLA CAMBIO (2ª)
	4	15140019	1	FORCELLA CAMBIO (3ª)	GEARBOX FORK (3RD)	FOURCHE BOÎTE DE VITESSES (3EME)	SCHALTGABEL 3.	HORQUILLA CAMBIO (3ª)
	5	15140020	1	PERNO FORCHETTE	AXES, FORKS	AXE FOURCHE	BOLZEN	EJE HORQUILLA
	6	15070043	1	SELETTORE CAMBIO	GEAR SHIFT SPINDLE, ASSY	SELECTEUR COMPL.	ZUSAMMENBAU SCHALTWALZE	CONJUNTO SELECTOR
	7	72011370	1	VITE PIASTRA FORCELLA INNESTO M6x20	BOLT, GEAR SHIFT FORK PLATE M6x20	VIS M6x20	SCHRAUBE M6x20	TORNILLO M6x20
	8	15090009	1	ROCCHETTO SELETTORE	SELECTOR SPROCKET	PIGNON SELECTEUR	SPULE SCHALTWALZE	PINON SELECTOR
	9	72011366	1	VITE M6x16	SCREW M6x16	VIS M6x16	SCHRAUBE M6x16	TORNILLO M6x16
	10	15080015	1	PIASTRINA	PLATE	PLAQUETTE	PLÄTTCHEN	PLACA
	11	72120085	1	MOLLA	SPRING	RESSORT	FEDER	MUELLE
	12	72040167	1	RONDELLA	WASHER	RONDELLE	UNTERLEGSCHIEBE	ARANDELA
	13	Z00062728	1	VITE TEF M6x20	FLANGED EXAGON HEAD SCREW M6x20	VIS M6x20	SCHRAUBE M6x20	TORNILLO M6x20
	14	F000P00870	1	GUIDACATENA LATO PIGNONE	DRIVE CHAIN	GUIDE DE CHAÎNE	KETTENFÜHRUNG	GUÍA CADENA
	15	14021193	1	COPERCHIO PIGNONE CATENA	CHAIN SPROCKET COVER	COUVERCLE PIGNON CHAÎNE	DECKEL KETTENRITZEL	TAPA PINON CADENA
	16	Z00062730	1	VITE TEF M6x30	FLANGED EXAGON HEAD SCREW M6x30	VIS M6x30	SCHRAUBE M6x30	TORNILLO M6x30
	17	ZE0067545	1	VITE TEF M6x40	BOLT M6x40	VIS M6x40	SCHRAUBE M6x40	TORNILLO M6x40
	18	F000A00517	1	ASS. LEVA COMANDO CAMBIO	GEAR CONTROL LEVER ASSY	LEVIER DE COM. BOÎTE DE VITESSES	ZSB. SCHALTHEBEL	CONJ. PALANCA MANDO CAMBIO
	19	72110009	1	ANELLO DI TENUTA OLIO Ø14x28x7	SEALING RING Ø14x28x7	BAGUE D'ETANCHEITE Ø14x28x7	DICHTUNGSRING Ø14x28x7	ANILLO DE ESTANQUEIDAD Ø14x28x7
	20	72011363	1	VITE SELETTORE CAMBIO M8x41	GEARSHIFT POSITIONING BOLT	VIS M8x41	SCHRAUBE M8x41	TORNILLO M8x41
	21	11040153	1	SENSORE FOLLE	NEUTRAL POSITION SWITCH	CAPTEUR POINT MORT	LEERLAUFSENSOR	SENSOR PUNTO MUERTO
	22	72040362	1	ROSETTA IN RAME	COPPER WASHER	RONDELLE	UNTERLEGSCHIEBE	ARANDELA

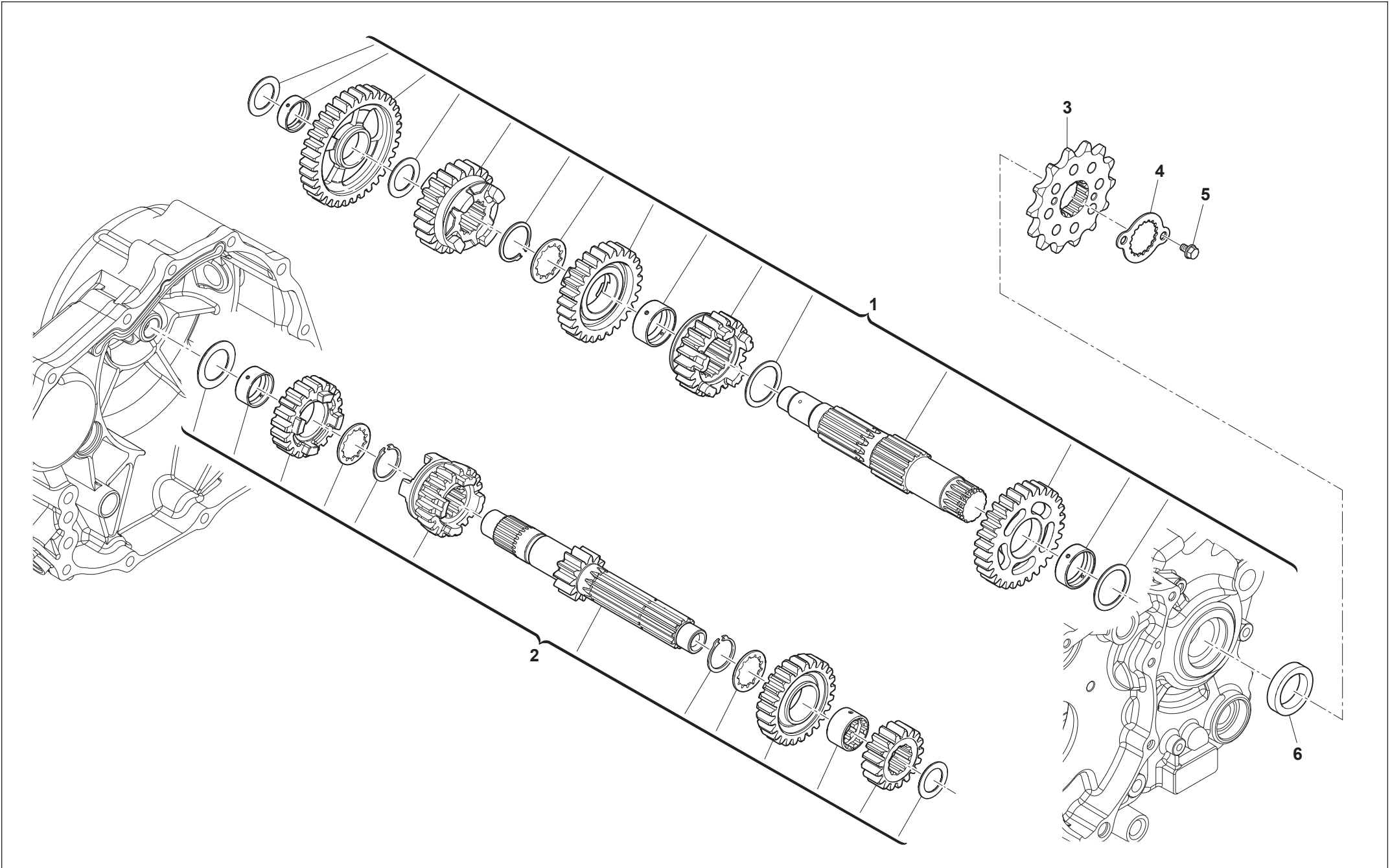

**GRAN MILANO 440**
TRASMISSIONE PRIMARIA - PRIMARY DRIVE
TRANSMISSION PRIMAIRE - PRIMÄRÜBERSETZUNG
TRANSMISION PRIMARIA

TAVOLA
DRAWING
TABLE
BILD
TABLA
13

Note Notes Marke Notas	Pos. No. Index Pos.	N. Cod. Code No. Nr. Code Code Nr N. Cod.	Q.tà Q.ty Q.te M.ge C.ad	DENOMINAZIONE	NAME	DESIGNATION	BESHREIBUNG	DENOMINACION
	1	15020081	1	ASSIEME ALBERO PRIMARIO	INPUT SHAFT ASSY	ARBRE PRIMAIRE COMPL.	ZUSAMMENBAU HAUPTANTRIEBSWELLE	CONJUNTO ARBOL PRIMARIO
	2	15030105	1	ASSIEME ALBERO SECONDARIO	OUTPUT SHAFT ASSY	ARBRE SECONDAIRE COMPL.	ZUSAMMENBAU VORGELEGEWELLE	CONJUNTO ARBOL SECUNDARIO
	3	15170121	1	PIGNONE USCITA CAMBIO Z=16	TRANSMISSION SPROCKET T=16	PIGNON SORTIE BOÎTE DE VITESSES Z=16	GETRIEBE-AUSGANGSRITZEL Z=16	PINON SALIDA CAMBIO Z=16
	4	73131476	1	PIASTRA FISSAGGIO PIGNONE	PINION FIXING BRACKET	PLAQUE PIGNON	RITZELPLATTE	PLACA PINON
	5	72011365	2	VITE M6x12	SCREW M6x12	VIS M6x12	SCHRAUBE M6x12	TORNILLO M6x12
	6	72110095	1	PARAOLIO Ø25x35x5	OIL SEAL Ø25x35x5	JOINT PARE-HUILE Ø25x35x5	ÖLDICHTRING Ø25x35x5	RETÉN DE ACEITE Ø25x35x5

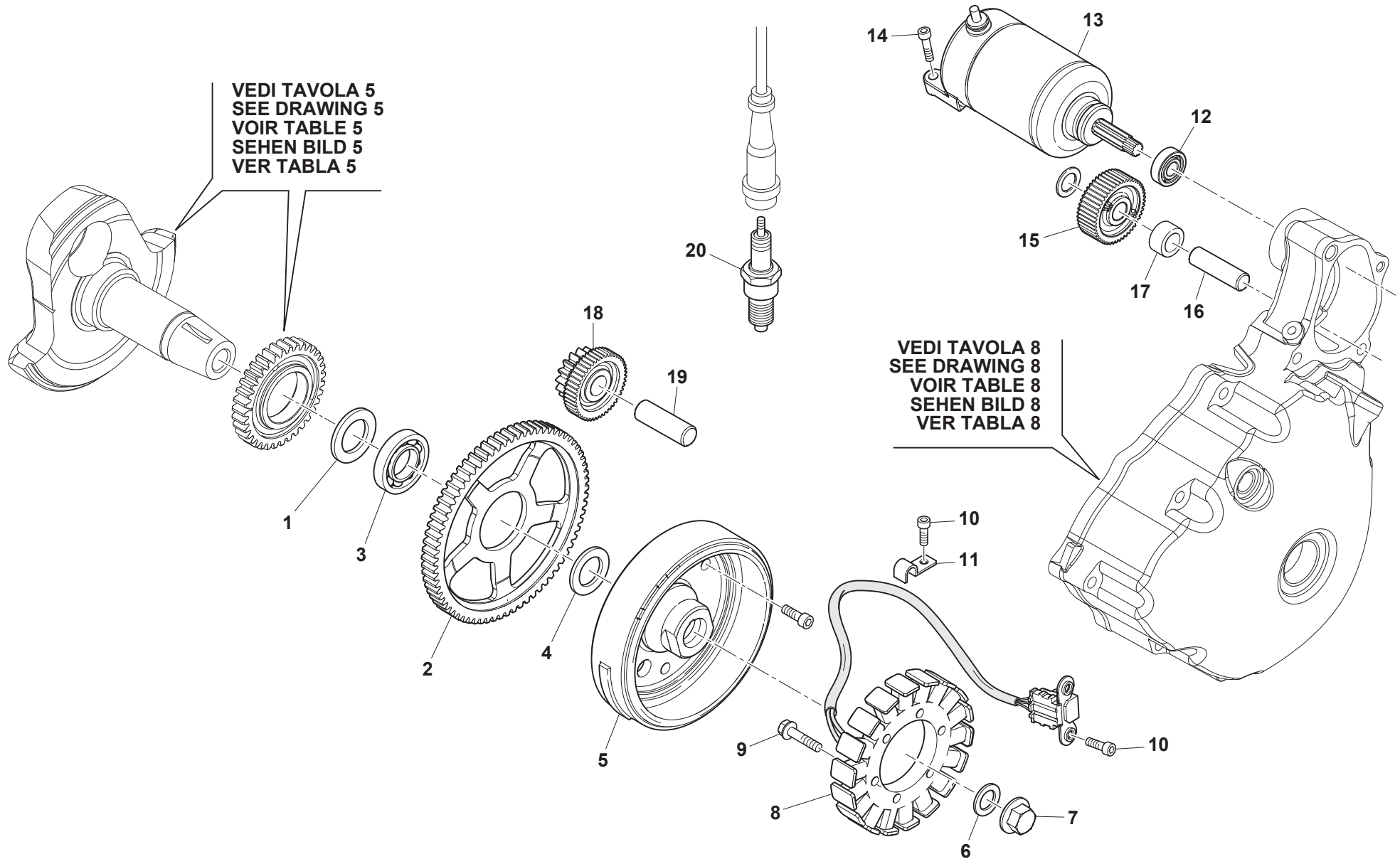



GRAN MILANO 440

PARTE ELETTRICA - IGNITION SYSTEM
PARTIES ELECTRIQUE - ELEKTRISCHE TEILE
PARTE ELECTRICA

TAVOLA
DRAWING
TABLE
BILD
TABLA

14

Table with 8 columns: Note, Pos. N., N. Cod., Q.tà, DENOMINAZIONE, NAME, DESIGNATION, BESHREIBUNG, DENOMINACION. Contains 20 rows of parts data including items like ROSETTA, INGR. FRIZIONE, CUSCINETTO, ROTORE, DADO, ASSIEME STATORE, VITE, PIASTRINA, CUSCINETTO 6000, MOTORINO, INGRANAGGIO, ALBERO INGRANAGGIO, BUSSOLA, PERNO, CANDELA.

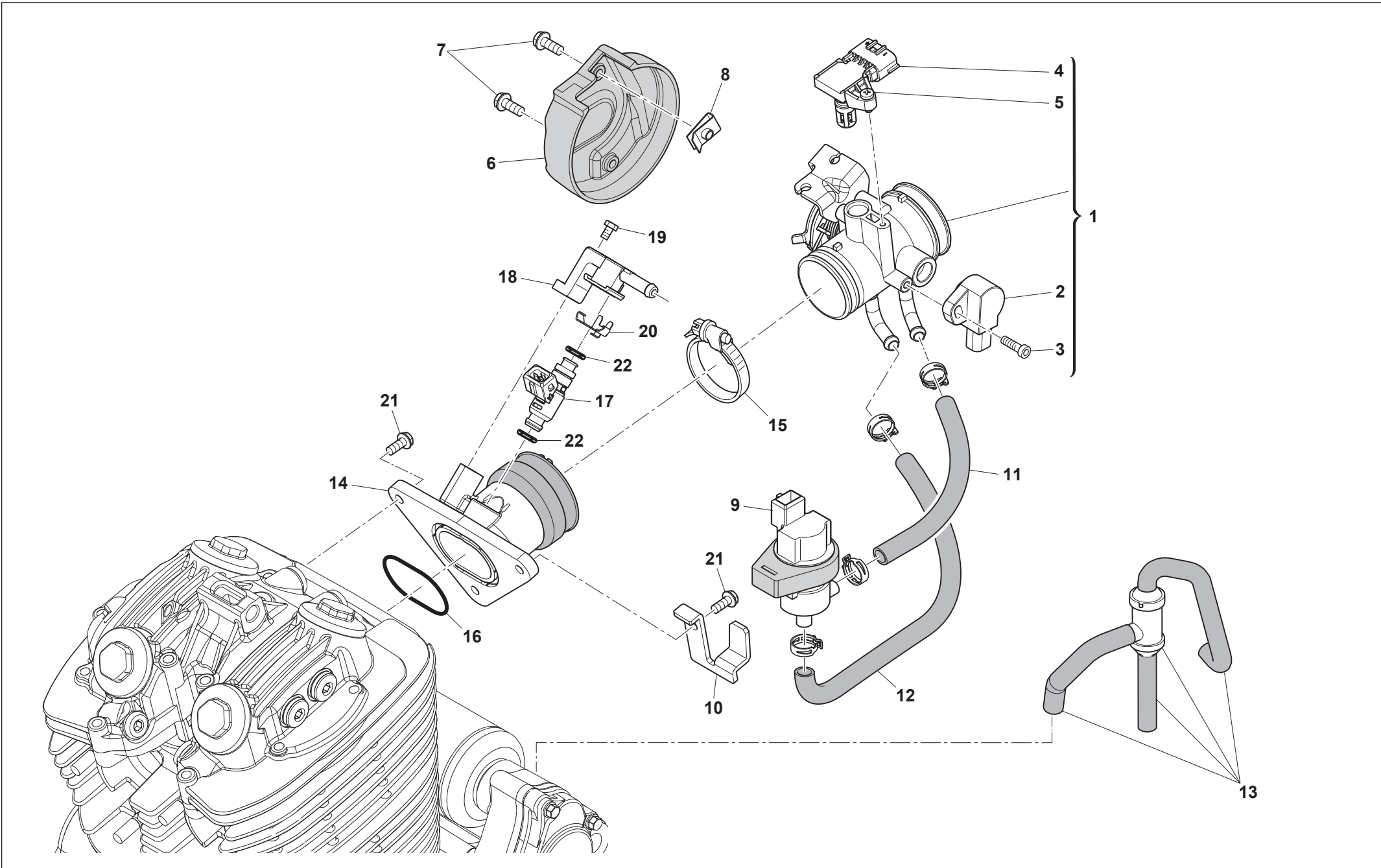



GRAN MILANO 440

CORPO FARFALLATO - THROTTLE BODY CORP PAPILLON - DROSSELKLAPPENKÖRPER CUERPO OSCILANTE

TAVOLA
DRAWING
TABLE
BILD
TABLA

15

Note Notes Notes Marke Notas	Pos. No. N. Index Pos.	N. Cod. Code No. Nr. Code Code Nr N. Cod.	Q.tà Q.ty Q.te M.ge C.ad	DENOMINAZIONE	NAME	DESIGNATION	BESHREIBUNG	DENOMINACION
	1	F000A00853	1	ASSIEME CORPO FARFALLATO	THROTTLE BODY ASSY	CORPS À PAPILLONS	DROSSELKÖRPER	CUERPO MARIPOSA
	2	31350080	1	SENSORE DI POSIZIONE	POSITION SENSOR	CAPTEUR	SENSOR	SENSOR
	3	72030657	1	VITE TCIC M4x16	SCREW M4x16	VIS M4x16	SCHRAUBE M4x16	TORNILLO M4x16
	4	31350057	1	SENSORE DI PRESSIONE	PRESSURE SENSOR	CAPTEUR DE PRESSION	DRUCKSENSOR	SENSOR PRESIÓN
	5	72030078	1	VITE TEF M5x12	FLANGED EXAGON HEAD SCREW M5x12	BOULON DE BRIDE M5x12	FLANSCHENSCHRAUBE M5x12	TORNILLO DE REBORDE M5x12
	6	F000P00855	1	COPERCHIO	COVER	COUVERCLE	DECKEL	TAPA
	7	Z00067997	2	VITE TEF M5x12	FLANGED EXAGON HEAD SCREW M5x12	BOULON DE BRIDE M5x12	FLANSCHENSCHRAUBE M5x12	TORNILLO DE REBORDE M5x12
	8	8000H2168	1	DADO A GRAFFETTA M5	CLIP NUT M5	ECROU À AGRAFE M5	SICHERUNGSMUTTER M5	TUERCA DE CLIP M5
	9	31350058	1	VALVOLA SOLENOIDE	SOLENOID VALVE	VANNE À SOLÉNOÏDE	MAGNETVENTIL	VÁLVULA SOLENOIDE
	10	73032134	1	SUPPORTO VALVOLA SOLENOIDE	SOLENOID VALVE BRACKET	SUPPORT	HALTERUNG	SOPORTE
	11	73090282	1	TUBO INGRESSO	INTAKE HOSE	TUYAU DE REFOULEMENT	VORLAUFROHR	TUBO ALIMENTACIÓN
	12	73090283	1	TUBO USCITA	OUTLET HOSE	TUYAU DE SORTIE	ANSCHLUSSROHR	TUBO SALIDA
	13	18050094	1	VALVOLA BLOW-BY CON TUBI FASCETTE E TAPPO	FUEL AND VAPOR SEPARATOR + CLIPS AND CAP	VANNE BLOW-BY	BLOW-BY VENTIL	VÁLVULA BLOW-BY
	14	F000P00849	1	COLLETTORE ASPIRAZIONE	INTAKE MANIFOLD	COLLECTEUR ADMISSION	KRÜMMER EINLASS	COLECTOR ADMISIÓN
	15	18170097	1	FASCETTA TJBC 40-60	CLIP TJBC 40-60	COLLIER TJBC 40-60	SHELLE TJBC 40-60	ABRAZADERA TJBC 40-60
	16	72150219	1	ANELLO OR	O-RING	JOINT TORIQUE	O-RING	JUNTA TORICA
	17	F000P00850	1	INIETTORE	INJECTOR	INJECTEUR	EINSPRITZDÜSE	INYECTOR
	18	F000P00851	1	CAPPUCCIO INIETTORE	INJECTOR CAP	CAPUCHON	KAPPE	CAPUCHÓN
	19	Z00062726	1	VITE TEF M6x14	FLANGED EXAGON HEAD SCREW M6x14	BOULON DE BRIDE M6x14	FLANSCHENSCHRAUBE M6x14	TORNILLO DE REBORDE M6x14
	20	F000P00852	1	FASCETTA	CLIP	COLLIER	SHELLE	ABRAZADERA
	21	Z00062729	3	VITE TEF M6x25	FLANGED EXAGON HEAD SCREW M6x25	BOULON DE BRIDE M6x25	FLANSCHENSCHRAUBE M6x25	TORNILLO DE REBORDE M6x25
	22	F000P01472	2	ANELLO OR	O-RING	JOINT TORIQUE	O-RING	JUNTA TORICA

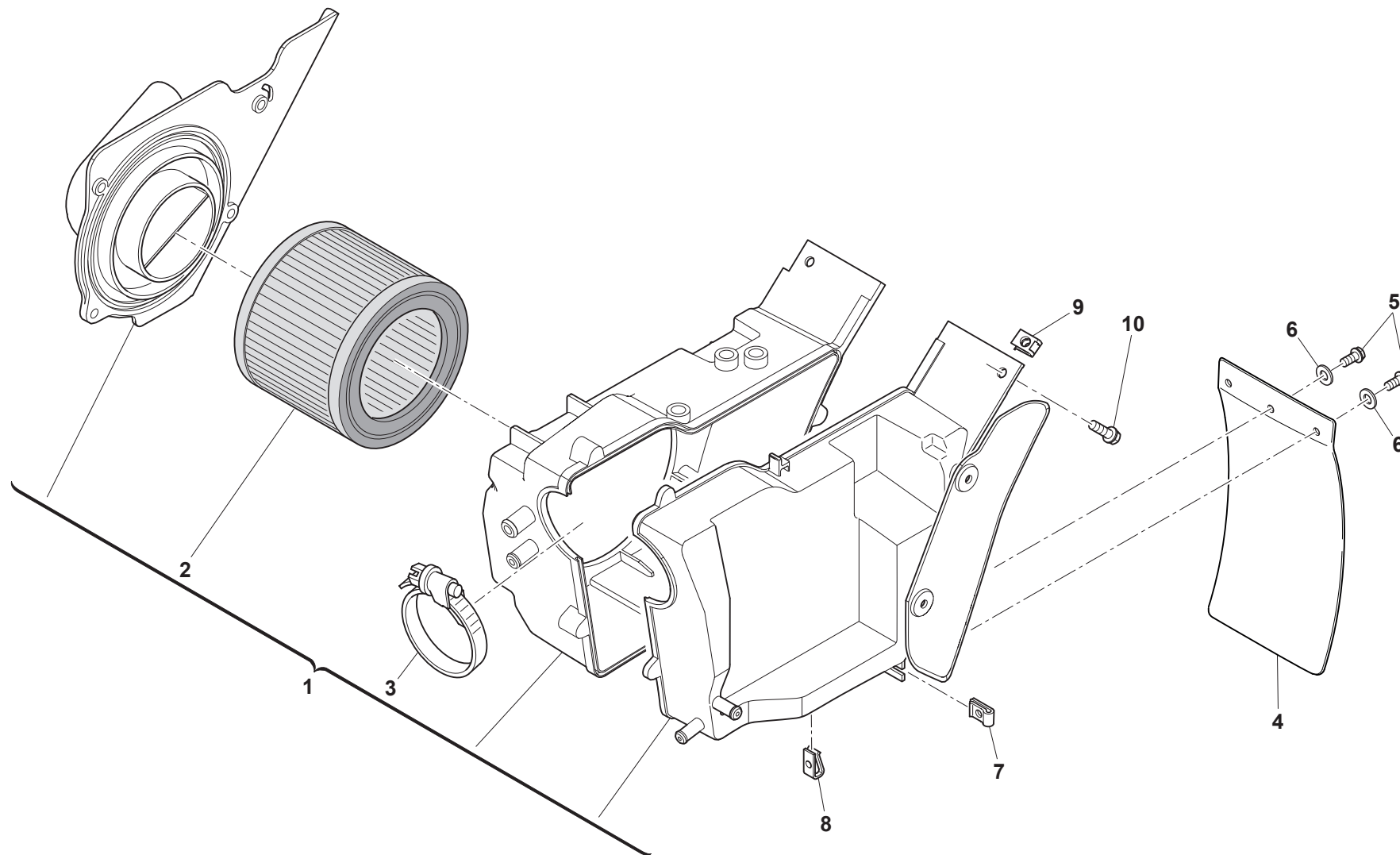



GRAN MILANO 440

FILTRO ARIA - AIR FILTER FILTRE AIRE - LUFTFILTER FILTRO DE AIRE

TAVOLA
DRAWING
TABLE
BILD
TABLA

16

Note Notes Notes Marke Notas	Pos. No. Index Pos.	N. Cod. Code No. Nr. Code Code Nr N. Cod.	Q.tà Q.ty Q.te M.ge C.ad	DENOMINAZIONE	NAME	DESIGNATION	BESHREIBUNG	DENOMINACION
	1	F000A00777	1	SCATOLA FILTRO ARIA	AIR FILTER BOX	BOÎTIER DE FILTRE À AIR	LUFTFILTERGEHÄUSE	CAJA FILTRO AIRE
	2	18130045	1	FILTRO ARIA	AIR FILTER	FILTRE À AIR	LUFTFILTER	FILTRO AIRE
	3	18170097	1	FASCETTA METALLICA TJBC 40-60	METALLIC CLIP TJBC 40-60	COLLIERT JBC 40-60	SCHELLE TJBC 40-60	ABRAZADERA TJBC 40-60
	4	73021054	1	PARASPRUZZI	INTERNAL REAR MUDGUARD	GARDE-BOUE ARRIÈRE INTÉRIEUR	HINTERRADKOTFLÜGEL INNEN	GUARDABARROS TRASERO INTERNO
	5	Z00067997	3	VITE TEF M5x12	FLANGED EXAGON HEAD SCREW M5x12	BOULON DE BRIDE M5x12	FLANSCHENSCHRAUBE M5x12	TORNILLO DE REBORDE M5x12
	6	62ND15548	3	ROSETTA	WASHER	RONDELLE	UNTERLEGSCHEIBE	ARANDELA
	7	U00055134	2	DADO A GRAFFETTA M5	CLIP NUT M5	ECROU À AGRAFE M5	SICHERUNGSMUTTER M5	TUERCA DE CLIP M5
	8	8000H2168	1	DADO A GRAFFETTA M5	CLIP NUT M5	ECROU À AGRAFE M5	SICHERUNGSMUTTER M5	TUERCA DE CLIP M5
	9	U00046893	2	DADO A GRAFFETTA M6	CLIP NUT M6	ECROU À AGRAFE M6	SICHERUNGSMUTTER M6	TUERCA DE CLIP M6
	10	Z00062727	2	VITE TEF M6x16	FLANGED EXAGON HEAD SCREW M6x16	BOULON DE BRIDE M6x16	FLANSCHENSCHRAUBE M6x16	TORNILLO DE REBORDE M6x16

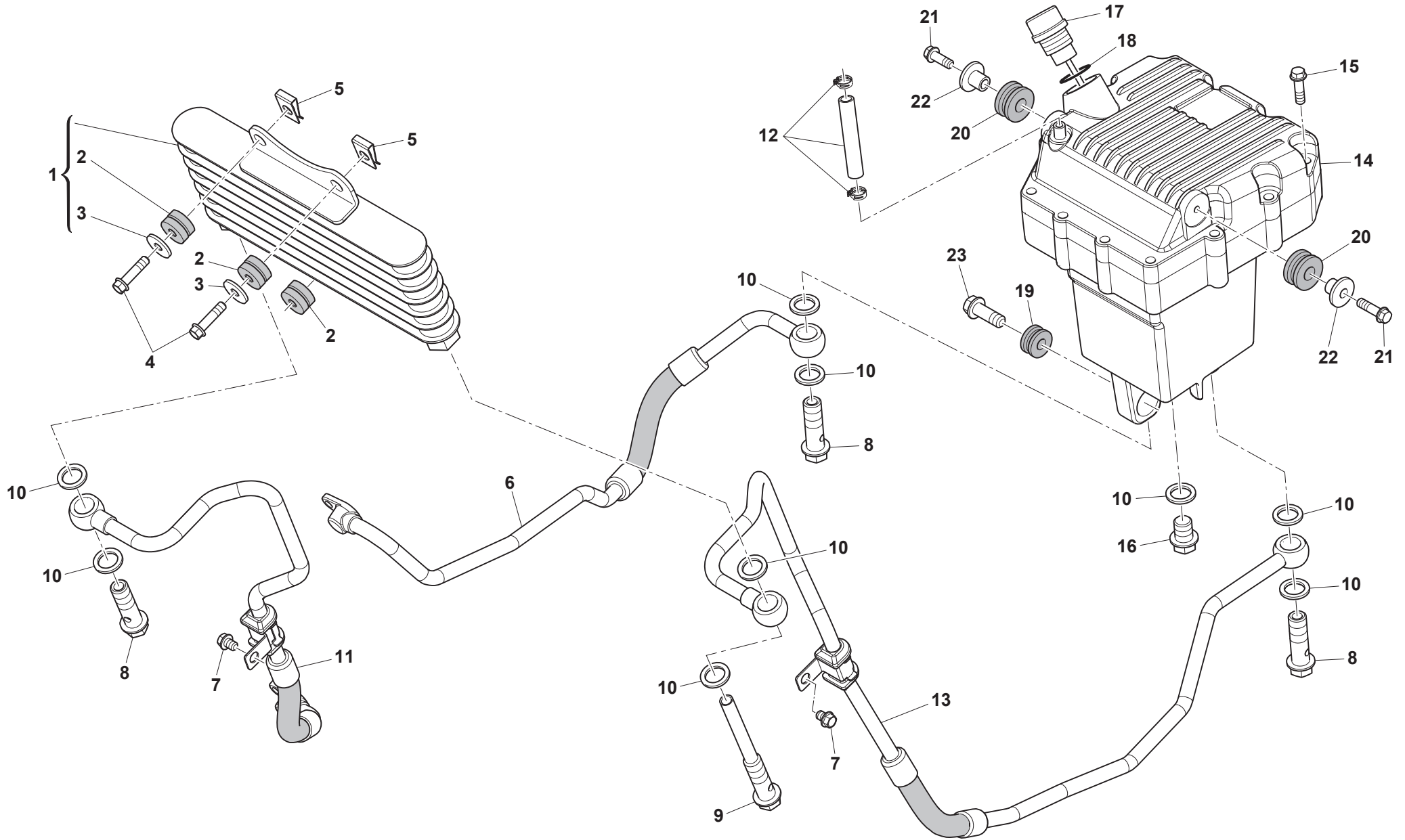



Note Notes Marke Notas	Pos. No. Index Pos.	N. Cod. Code No. Nr. Code Code Nr N. Cod.	Q.tà Q.ty Q.te M.ge C.ad	DENOMINAZIONE	NAME	DESIGNATION	BESHREIBUNG	DENOMINACION
	1	F000A00447	1	RADIATORE OLIO COMPLETO	OIL COOLER ASSY	RADIATEUR HUILE COMPLET	ÖLKÜHLER KOMPLETT	RADIADOR ACEITE COMPLETO
	2	F000P00774	3	GOMMINO RADIATORE OLIO	OIL COOLER RUBBER	JOINT EN CAOUTCHOUC	GUMMISCHEIBE	GOMA
	3	F000P00775	2	DISTANZIALE	SPACER	ENTRETOISE	ABSTANDHALTER	DISTANCIADOR
	4	Z00062729	2	VITE TEF M6x25	FLANGED EXAGON HEAD SCREW M6x25	BOULON DE BRIDE M6x25	FLANSCHENSCHRAUBE M6x25	TORNILLO DE REBORDE M6x25
	5	U00046893	2	DADO A GRAFFETTA M6	CLIP NUT M6	ECROU À AGRAFE M6	SICHERUNGSMUTTER M6	TUERCA DE CLIP M6
	6	F000P00452	1	TUBO SERBATOIO-MOTORE	OIL PIPE TANK-ENGINE	TUBE RÉSERVOIR-MOTEUR	ROHR TANK-MOTOR	TUBO DEPÓSITO-MOTOR
	7	ZS0067545	2	VITE TEF M6x8	FLANGED EXAGON HEAD SCREW M6x8	BOULON DE BRIDE M6x8	FLANSCHENSCHRAUBE M6x8	TORNILLO DE REBORDE M6x8
	8	72012140	3	VITE FORATA M12x1,25x30	LIQUID BOLT M12x1,25x30	VIS M12x1,25x30	SCHRAUBE M12x1,25x30	TORNILLO M12x1,25x30
	9	F000P00742	1	VITE FORATA SPECIALE	SPECIAL LIQUID BOLT	VIS SPÉCIAUX	SPEZIALSCHRAUBE	TORNILLO ESPECIAL
	10	72040159	9	ROSETTA DI TENUTA	SEALING WASHER	RONDELLE D'ETANCHEITE	DICHTUNGSSCHEIBE	ARANDELA DE ESTANQUEIDAD
	11	F000A00843	1	TUBO MOTORE-RADIATORE	PIPE ENGINE-TANK	TUBE MOTEUR-RÉSERVOIR	ROHR MOTOR-TANK	TUBO MOTOR-DEPÓSITO
	12	17060151	1	TUBO TESTA-SERBATOIO CON CLIPS	CYLINDER HEAD-OIL TANK HOSE WITH CLIPS	TUBE MOTEUR-RÉSERVOIR	ROHR MOTOR-TANK	TUBO MOTOR-DEPÓSITO
	13	F000A00844	1	TUBO RADIATORE-SERBATOIO	OIL PIPE COOLER-TANK	TUBE RADIATEUR-RÉSERVOIR	ROHR ÖLKÜHLER-TANK	TUBO RADIADOR-DEPÓSITO
	14	M000A00643	1	ASS. SERBATOIO OLIO	OIL TANK ASSY	RÉSERVOIR D'HUILE COMPLET	ÖLBEHÄLTER KOMPLETT	DEPÓSITO ACEITE COMPLETO
	15	72010387	12	VITE TEF M6x28	FLANGED EXAGON HEAD SCREW M6x28	BOULON DE BRIDE M6x28	FLANSCHENSCHRAUBE M6x28	TORNILLO DE REBORDE M6x28
	16	72012089	1	TAPPO OLIO INFERIORE	LOWER OIL CAP	BOUCHON	STOPFEN	TAPON
	17	73010172	1	TAPPO OLIO	OIL CAP	BOUCHON	STOPFEN	TAPON
	18	72150018	1	ANELLO OR	OIL CAP O-RING	JOINT TORIQUE	O-RING	JUNTA TORICA
	19	73012333	2	SILENT-BLOCK	SILENT-BLOCK	SILENT-BLOCK	SILENT-BLOCK	SILENT-BLOCK
	20	73012321	2	GOMMINO	RUBBER RING	JOINT EN CAOUTCHOUC	GUMMISCHEIBE	GOMA
	21	Z00062728	2	VITE TEF M6x20	FLANGED EXAGON HEAD SCREW M6x20	BOULON DE BRIDE M6x20	FLANSCHENSCHRAUBE M6x20	TORNILLO DE REBORDE M6x20
	22	72040551	2	BUSSOLA FLANGIATA Ø6,5x18x7	FLANGED BUSH Ø6,5x18x7	DOUILLE À BRIDE Ø6,5x18x7	FLANSCHBUCHSE Ø6,5x18x7	CASQUILLO CON BRIDA Ø6,5x18x7
	23	8A00B1959	1	VITE TEF M8x30	FLANGED EXAGON HEAD SCREW M8x30	BOULON DE BRIDE M8x30	FLANSCHENSCHRAUBE M8x30	TORNILLO DE REBORDE M8x30

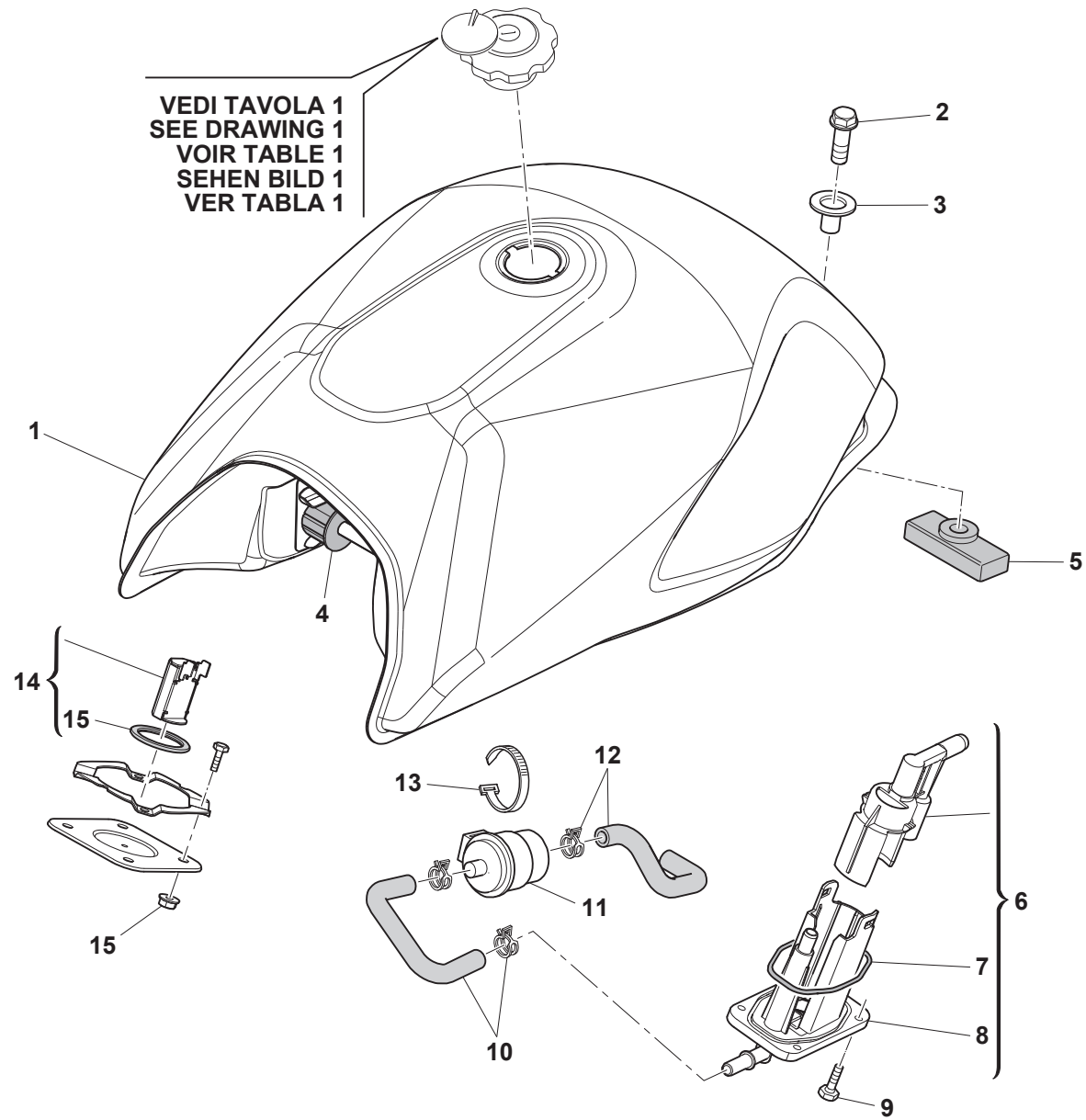



GRAN MILANO 440

SERBATOIO CARBURANTE - FUEL TANK RESERVOIR CARBURANT - KRAFTSTOFFBEHALTER DEPOSITO GASOLINA

TAVOLA
DRAWING
TABLE
BILD
TABLA

18

Note Notes Notes Marke Notas	Pos. No. N. Index Pos.	N. Cod. Code No. Nr. Code Code Nr N. Cod.	Q.tà Q.ty Q.te M.ge C.ad	DENOMINAZIONE	NAME	DESIGNATION	BESHREIBUNG	DENOMINACION
	1	F0A0A00295	1	ASS. SERBATOIO CARBURANTE	FUEL TANK ASSY	RÉSERVOIR DE CARBURANT COMPLET	KRAFTSTOFFTANK KOMPLETT	DEPÓSITO COMBUSTIBLE COMPLETO
	2	72011245	1	VITE TEF M8x30	FLANGED EXAGON HEAD SCREW M8x30	BOULON DE BRIDE M8x30	FLANSCHENSCHRAUBE M8x30	TORNILLO DE REBORDE M8x30
	3	70120233	1	BUSSOLA	BUSHING	DOUILLE	BUCHSE	CASQUILLO
	4	73012149	2	TAMPONE LATERALE SERBATOIO	FRONT DAMPING MAT	TAMPON LATÉRALE	PUFFER SEITLICH	TACO LATERAL
	5	73012489	1	TAMPONE POSTERIORE SERBATOIO	REAR DAMPING MAT	TAMPON ARRIÈRE	PUFFER HINTEN	TACO TRASERO
	6	31350039	1	POMPA BENZINA	FUEL PUMP	POMPE À CARBURANT	BENZINPUMPE	BOMBA GASOLINA
	7	31350081	1	GUARNIZIONE POMPA BENZINA	FUEL PUMP GASKET	JOINT POMPE DE CARBURANT	DICHTUNG PUMPE	JUNTA BOMBA COMBUSTIBLE
	8	31350083	1	PIASTRA METALLICA	METALLIC PLATE	PLAQUE	PLATTE	PLACA
	9	72030657	4	VITE M4x16	BOLT M4x16	VIS M4x16	SCHRAUBE M4x16	TORNILLO M4x16
	10	F000A00761	1	TUBO MANDATA BENZINA CON CLIPS	PUMP- FUEL FILTER HOSE WITH CLIPS	TUYAU DE REFOULEMENT	VORLAUFROHR	TUBO ALIMENTACIÓN
	11	F000P00915	1	FILTRO BENZINA	FUEL FILTER	FILTRE DE CARBURANT	BENZINFILTER	FILTRO COMBUSTIBLE
	12	F000P00913	1	TUBO FILTRO-INIETTORE CON CLIPS	FUEL FILTER-INJECTOR HOSE WITH CLIPS	TUBE FILTRE-INJECTEUR	ROHR FILTER-EINSPRITZDÜSE	TUBO FILTRO-INYECTOR
	13	F000P00916	1	FASCETTA	CLAMP	COLLIER	SCHELLE	ABRAZADERA
	14	31130115	1	SENSORE LIVELLO BENZINA	FUEL SENDER ASSY	CAPTEUR	SENSOR	SENSOR
	15	31130117	1	GUARNIZIONE	FUEL SENDER GASKET	JOINT	DICHTUNG	JUNTA
	16	72020178	4	DADO M6	NUT M6	ECROU M6	MUTTER M6	TUERCA M6

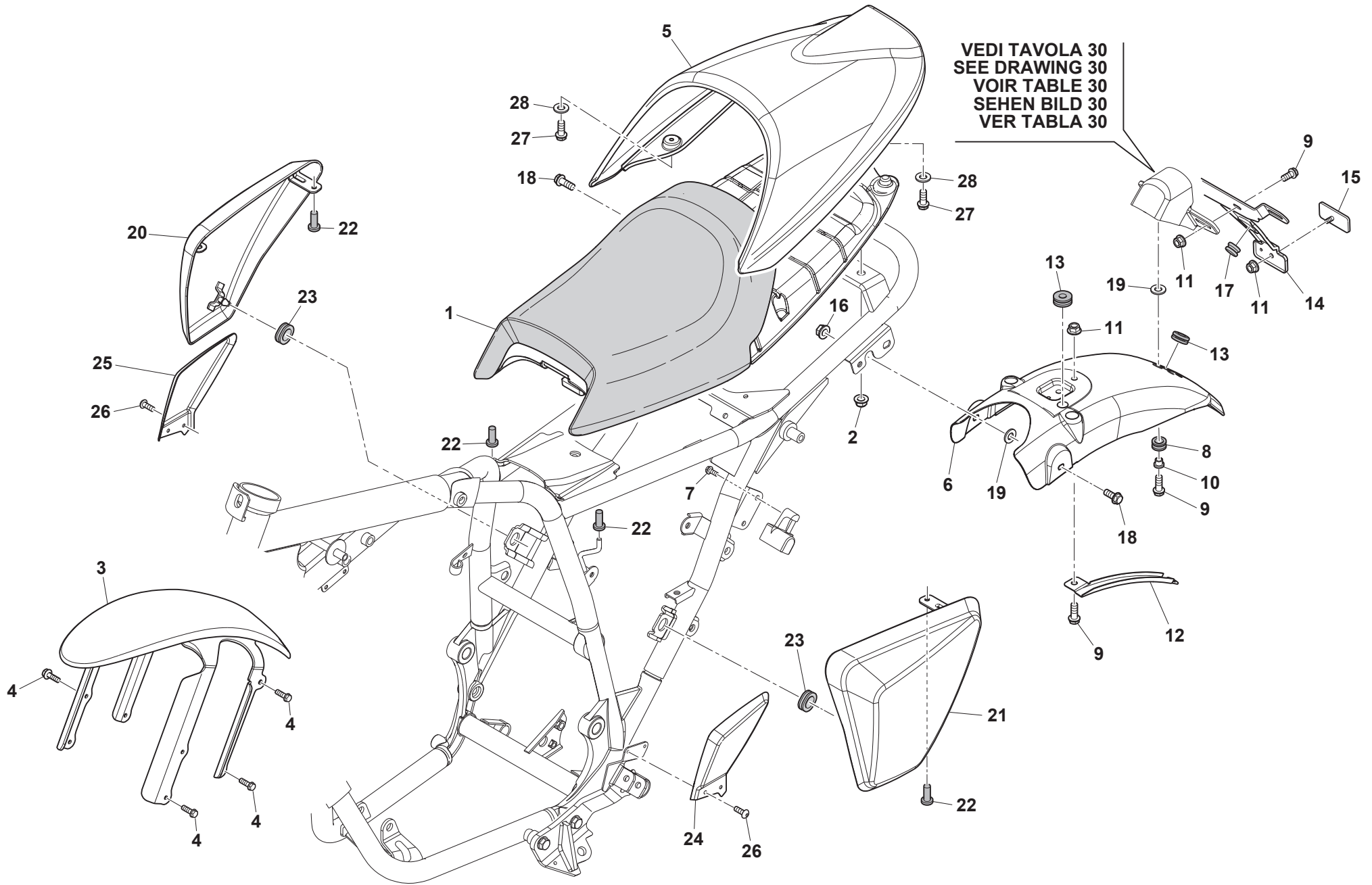



GRAN MILANO 440

PANNELLI, PARAFANGHI, SELLA - PANEL, FENDERS, SEAT PANNEAU, GARDE-BOUES, SIEGE - STREIFEN, KOTFLUGEL, SATTEL PANELO, GUARDABARROS, SILLIN

TAVOLA
DRAWING
TABLE
BILD
TABLA

19

Note Notes Notes Marke Notas	Pos. No. N. Index Pos.	N. Cod. Code No. Nr. Code Code Nr N. Cod.	Q.tà Q.ty Q.te M.ge C.ad	DENOMINAZIONE	NAME	DESIGNATION	BESHREIBUNG	DENOMINACION
	1	F000A00454	1	SELLA	SADDLE	SELLE	SITZBANK	ASIENTO
	2	Y00043928	2	DADO FRENATO M8x12	SELF-LOCKING NUT M8x12	ECROU AUTOBLOQUANT M8x12	SELBSTSICHERNDE MUTTER M8x12	TUERCA AUTOBLOCANTE M8x12
	3	F000P00285	1	PARAFANGO ANTERIORE	FRONT MUDGUARD	GARDE-BOUE AVANT	VORDERRADKOTFLÜGEL	GUARDABARROS DELANTERO
	4	Z00067997	6	VITE TEF M5x12	FLANGED EXAGON HEAD SCREW M5x12	BOULON DE BRIDE M5x12	FLANSCHENSCHRAUBE M5x12	TORNILLO DE REBORDE M5x12
	5	F000P00278	1	CODA	TAIL	QUEUE	ENDSTÜCK	COLA
	6	F000P00287	1	PARAFANGO POSTERIORE	REAR MUDGUARD	GARDE-BOUE ARRIÈRE	HINTERRADKOTFLÜGEL	GUARDABARROS TRASERO
	7	ZH0067545	2	VITE TEF M6x12	FLANGED EXAGON HEAD SCREW M6x12	BOULON DE BRIDE M6x12	FLANSCHENSCHRAUBE M6x12	TORNILLO DE REBORDE M6x12
	8	800041862	3	PASSACAVO	CABLE RING	PASSE-CÂBLE	KABELDURCHFÜHRUNG	PASACABLE
	9	Z00062727	5	VITE TEF M6x16	FLANGED EXAGON HEAD SCREW M6x16	BOULON DE BRIDE M6x16	FLANSCHENSCHRAUBE M6x16	TORNILLO DE REBORDE M6x16
	10	8C00B2799	3	DISTANZIALE CON COLLETTO	SPACER WITH COLLAR	ENTRETOISE	ABSTANDHALTER	DISTANCIADOR
	11	Z00044240	4	DADO AUTOBLOCCANTE	SELF-LOCKING NUT	ECROU AUTOBLOQUANT	SELBSTSICHERNDE MUTTER	TUERCA AUTOBLOCANTE
	12	73032132	1	PIASTRINA	PLATE	PLAQUETTE	PLÄTTCHEN	PLACA
	13	73012329	2	GOMMINO PASSAGGIO CAVI	RUBBER SLEEVE	JOINT EN CAOUTCHOUC	GUMMISCHEIBE	GOMA
	14	73280100	1	SUPPORTO TARGA	LICENCE PLATE SUPPORT	SUPPORT PLAQUE D'IMM.	KENNZEICHENHALTERUNG	SOPORTE MATRÍCULA
	15	73060039	1	CATADIOTTRO	REFLECTOR	CATADIOPTRE	RÜCKSTRAHLER	CATADIÓPTRICO
	16	Z00061313	2	DADO M6	NUT M6	ECROU M6	MUTTER M6	TUERCA M6
	17	73012164	1	GOMMINO PER PORTATARGA	CUSHION RUBBER, REAR LICENSE	JOINT EN CAOUTCHOUC	GUMMISCHEIBE	GOMA
	18	ZH0067545	6	VITE TEF M6x12	FLANGED EXAGON HEAD SCREW M6x12	BOULON DE BRIDE M6x12	FLANSCHENSCHRAUBE M6x12	TORNILLO DE REBORDE M6x12
	19	62ND15504	5	ROSETTA	WASHER	RONDELLE	UNTERLEGSCHEIBE	ARANDELA
	20	FOA0A00306	1	PANNELLO DESTRO	RIGHT SIDE PANEL	PANNEAU DROITE	PANEEL RECHTS	PANEL DERECHO
	21	FOA0A00305	1	PANNELLO SINISTRO	LEFT SIDE PANEL	PANNEAU GAUCHE	PANEEL LINKS	PANEL IZQUIERDO
	22	73012510	4	GOMMINO ANTIVIBRANTE	SILENT-BLOCK	ANTIVIBRATION	SCHWINGUNGSDAMFER	ANTIVIBRADOR
	23	73010065	2	GOMMINO	RUBBER RING	JOINT EN CAOUTCHOUC	GUMMISCHEIBE	GOMA
	24	F000P00310	1	PROTEZIONE DESTRA	R.H. PROTECTION	PROTECTION DROIT	SCHUTZ RECHTS	PROTECCIÓN DCH.
	25	F000P00456	1	PROTEZIONE SINISTRA	L.H. PROTECTION	PROTECTION GAUCHE	SCHUTZ LINKS	PROTECCIÓN IZQ.
	26	ZA0059572	4	VITE TBEI M5x12	BOLT TBEI M5x12	VIS TBEI M5x12	SCHRAUBE TBEI M5x12	TORNILLO TBEI M5x12
	27	Z00062726	2	VITE TEF M6x14	FLANGED EXAGON HEAD SCREW M6x14	BOULON DE BRIDE M6x14	FLANSCHENSCHRAUBE M6x14	TORNILLO DE REBORDE M6x14
	28	Z00021535	2	RONDELLA	WASHER	RONDELLE	UNTERLEGSCHEIBE	ARANDELA

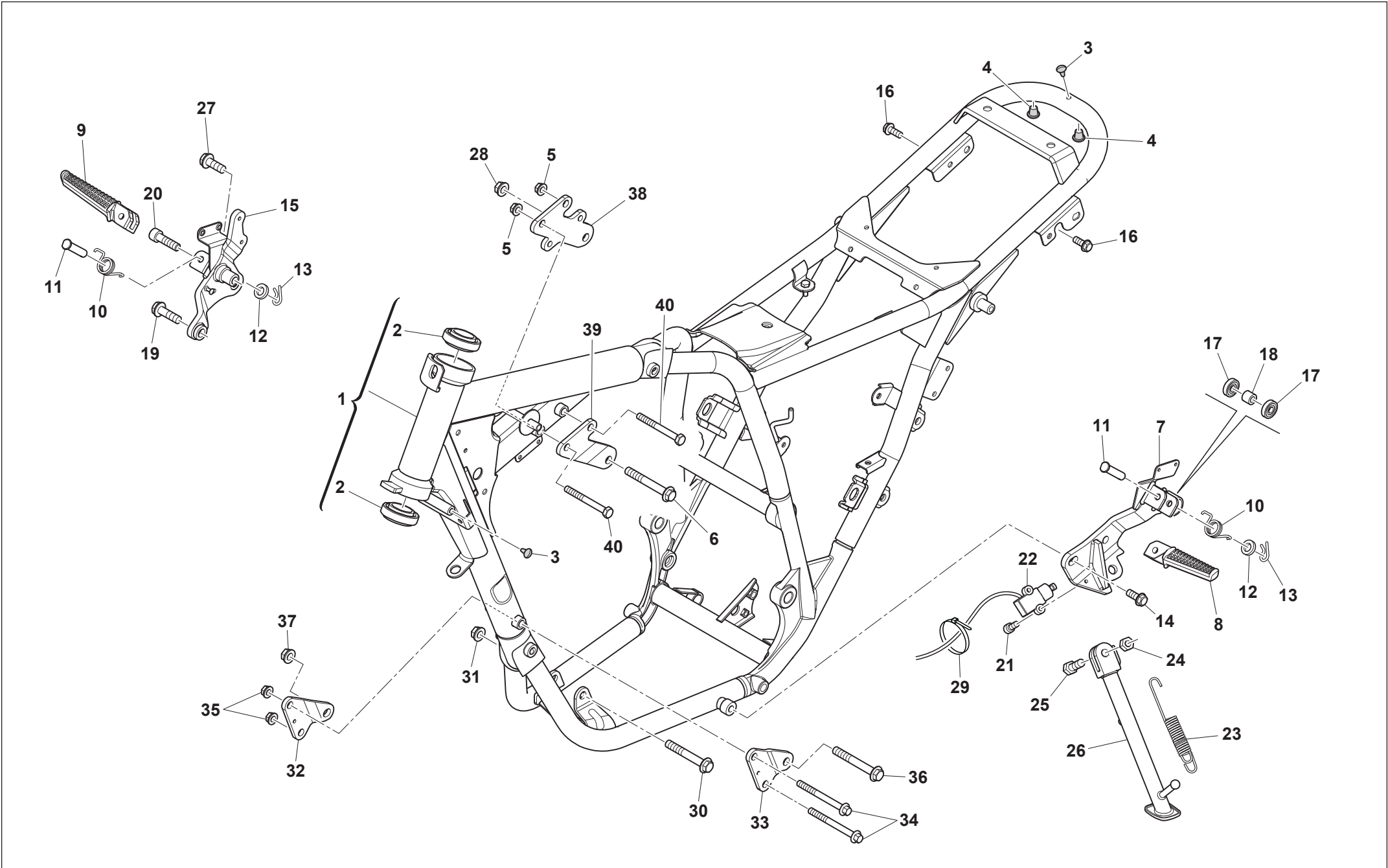



GRAN MILANO 440

TELAIO, PEDANE - FRAME, FOOT RESTS CADRE, REPOSE PIEDS - RAHMEN, FUSSBRETT BASTIDOR, REPOSAPIES

TAVOLA
DRAWING
TABLE
BILD
TABLA

20

Note Notes Notes Marke Notas	Pos. No. N. Index Pos.	N. Cod. Code No. Nr. Code Code Nr N. Cod.	Q.tà Q.ty Q.te M.ge C.ad	DENOMINAZIONE	NAME	DESIGNATION	BESHREIBUNG	DENOMINACION
	1	F0A0A00480	1	TELAIO CON CUSCINETTI	FRAME WITH BEARINGS	CHÂSSIS AVEC ROULEMENTS	RAHMEN MIT LAGERN	CHASIS CON COJINETES
	2	800087243	2	CUSCINETTO A RULLI CONICI	TAPERED ROLLER BEARING	ROULEMENT À ROULEAUX CONIQUES	KEGELROLLENLAGER	COJINETE DE RODILLOS CÓNICOS
	3	800058394	3	TAMPONE IN GOMMA	RUBBER BUFFER	TAMPON	PUFFER	TACO
	4	F000P01119	2	TAMPONE IN GOMMA	RUBBER BUFFER	TAMPON	PUFFER	TACO
	5	Z00069056	4	VITE TEF M8x20	FLANGED EXAGON HEAD SCREW M8x20	BOULON DE BRIDE M8x20	FLANSCHENSCHRAUBE M8x20	TORNILLO DE REBORDE M8x20
	6	ZT0069138	1	VITE TEF M10x70	SCREW M10x70	BOULON DE BRIDE M10x70	FLANSCHENSCHRAUBE M10x70	TORNILLO DE REBORDE M10x70
	7	F000A00445	1	SUPPORTO PEDANA SINISTRA	L.H. FOOTREST SUPPORT	SUPPORT REPOSE-PIEDS GAUCHE	HALTERUNG FUßRASTE LINKS	SOPORTE ESTRIBO IZQUIERDA
	8	F000P00698	1	PEDANA SINISTRA	L.H. FOOTREST	REPOSE-PIEDS GAUCHE	FUßRASTE LINKS	ESTRIBO IZQUIERDA
	9	F000P00699	1	PEDANA DESTRA	R.H. FOOTREST	REPOSE-PIEDS DROITE	FUßRASTE RECHTS	ESTRIBO DERECHA
	10	F000P00822	2	MOLLA PEDANA SINISTRA	SPRING	RESSORT	FEDER	MUELLE
	11	F000P00823	2	PERNO	PIN	AXE	BOLZEN	EJE
	12	Z00056377	2	ROSETTA	WASHER	RONDELLE	UNTERLEGSSCHEIBE	ARANDELA
	13	64ND20068	2	COPIGLIA	SPLIT PIN	GOUPILLE	SPLINT	PASADOR
	14	ZG0062797	2	VITE TEF M10x22	FLANGED EXAGON HEAD SCREW M10x22	BOULON DE BRIDE M10x22	FLANSCHENSCHRAUBE M10x22	TORNILLO DE REBORDE M10x22
	15	F000A00446	1	SUPPORTO PEDANA DESTRA	R.H. FOOTREST SUPPORT	SUPPORT REPOSE-PIEDS DROITE	HALTERUNG FUßRASTE RECHTS	SOPORTE ESTRIBO DERECHA
	16	ZF0062797	1	VITE TEF M10x30	FLANGED EXAGON HEAD SCREW M10x30	BOULON DE BRIDE M10x30	FLANSCHENSCHRAUBE M10x30	TORNILLO DE REBORDE M10x30
	17	70090215	2	CUSCINETTO 6900	BEARING 6900	ROULEMENT 6900	LAGER 6900	COJINETE 6900
	18	70180041	1	DISTANZIALE INTERNO	INTERNAL SPACER	ENTRETOISE INTÉRIEUR	INTERNER ABSTANDHALTER	DISTANCIADOR INTERNO
	19	ZG0062797	1	VITE TEF M10x22	FLANGED EXAGON HEAD SCREW M10x22	BOULON DE BRIDE M10x22	FLANSCHENSCHRAUBE M10x22	TORNILLO DE REBORDE M10x22
	20	YN0082751	1	VITE TCEIF M10x40	SCREW TCEIF M10x40	VIS TCEIF M10x40	SCHRAUBE TCEIF M10x40	TORNILLO TCEIF M10x40
	21	60ND07330	2	VITE TCEI M5x16	SCREW TCEI M5x16	VIS TCEI M5x16	SCHRAUBE TCEI M5x16	TORNILLO TCEI M5x16
	22	31120016	1	INTERRUTTORE CAVALLETTO	POWEROFF SWITCH	INTERRUPTEUR	SCHALTER	INTERRUPTOR
	23	72050555	1	MOLLA	SPRING	RESSORT	FEDER	MUELLE
	24	72020534	1	DADO	NUT	ECROU	MUTTER	TUERCA
	25	72030710	1	VITE ROTAZIONE CAVALLETTO LATERALE	SIDE STAND SCREW	VIS BÉQUILLE	SCHRAUBE STÄNDER	TORNILLO CABALLETE
	26	F0A0P00519	1	CAVALLETTO LATERALE	LATERAL STAND	BÉQUILLE	STÄNDER	CABALLETE LATERAL
	27	Y00043928	2	DADO FLANGIATO M8	FLANGED NUT M8	ECROU BRIDE M8	FLANSCHMUTTER M8	TUERCA CON BRIDA M8
	28	Z00042022	1	DADO FLANGIATO M10	FLANGED NUT M10	ECROU BRIDE M10	FLANSCHMUTTER M10	TUERCA CON BRIDA M10
	29	800056444	1	FASCETTA L=188 mm	CLAMP L=188 mm	COLLIER L=188 mm	SHELLE L=188 mm	ABRAZADERA L=188 mm
	30	ZT0069138	1	VITE TEF M10x70	SCREW M10x70	BOULON DE BRIDE M10x70	FLANSCHENSCHRAUBE M10x70	TORNILLO DE REBORDE M10x70
	31	Z00042022	1	DADO FLANGIATO M10	FLANGED NUT M10	ECROU BRIDE M10	FLANSCHMUTTER M10	TUERCA CON BRIDA M10
	32	F0A0P00482	1	PIASTRA ANT. DESTRA MOTORE	R.H. FRONT ENGINE PLATE	PLAQUE MOTEUR AV. DROIT	PLATTE MOTOR VORNE RECHTS	PLACA MOTOR DEL. DER.
	33	F0A0P00483	1	PIASTRA ANT. SINISTRA MOTORE	L.H. FRONT ENGINE PLATE	PLAQUE MOTEUR AV. GAUCHE	PLATTE MOTOR VORNE LINKE	PLACA MOTOR DEL. IZQ.

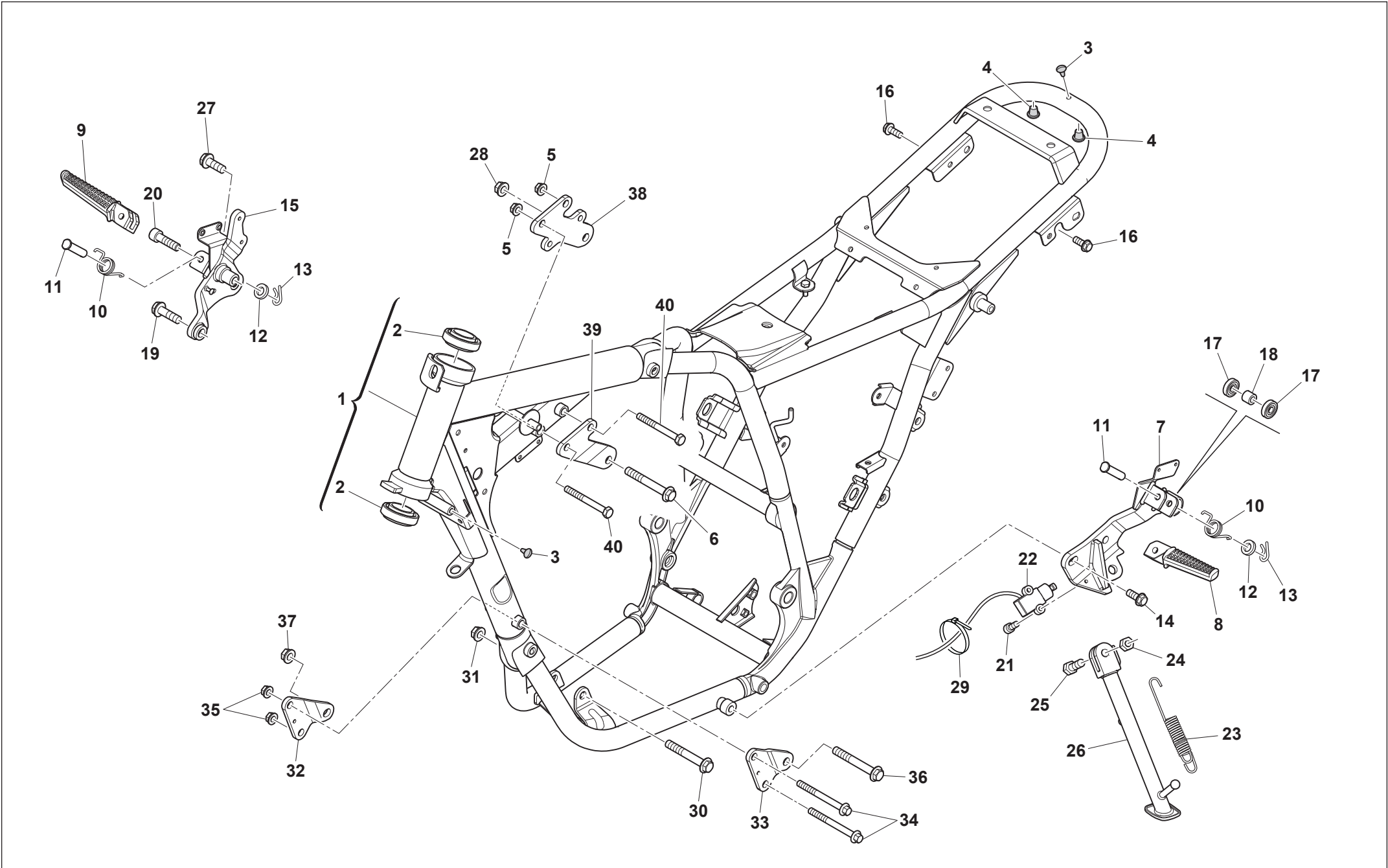



Note Notes Marke Notas	Pos. No. Index Pos.	N. Cod. Code No. Nr. Code Code Nr N. Cod.	Q.tà Q.ty Q.te M.ge C.ad	DENOMINAZIONE	NAME	DESIGNATION	BESHREIBUNG	DENOMINACION
	34	YU0073458	2	VITE M8x85	SCREW M8x85	VIS M8x85	SCHRAUBE M8x85	TORNILLO M8x85
	35	Y00043928	2	DADO FLANGIATO M8	FLANGED NUT M8	ECROU BRIDE M8	FLANSCHMUTTER M8	TUERCA CON BRIDA M8
	36	ZS0069138	1	VITE TEF M10x75	FLANGED EXAGON HEAD SCREW M10x75	BOULON DE BRIDE M10x75	FLANSCHENSCHRAUBE M10x75	TORNILLO DE REBORDE M10x75
	37	Z00042022	1	DADO FLANGIATO M10	FLANGED NUT M10	ECROU BRIDE M10	FLANSCHMUTTER M10	TUERCA CON BRIDA M10
	38	F0A0P00633	1	PIASTRA MOTORE DESTRA	R.H. ENGINE PLATE	PLAQUE MOTEUR D.	PLATTE MOTOR RECHTS	PLACA MOTOR DER.
	39	F0A0P00634	1	PIASTRA MOTORE SINISTRA	L.H. ENGINE PLATE	PLAQUE MOTEUR G.	PLATTE MOTOR LINKE	PLACA MOTOR IZQ.
	40	ZV0073458	2	VITE TEF M8x75	FLANGED EXAGON HEAD SCREW M8x75	BOULON DE BRIDE M8x75	FLANSCHENSCHRAUBE M8x75	TORNILLO DE REBORDE M8x75

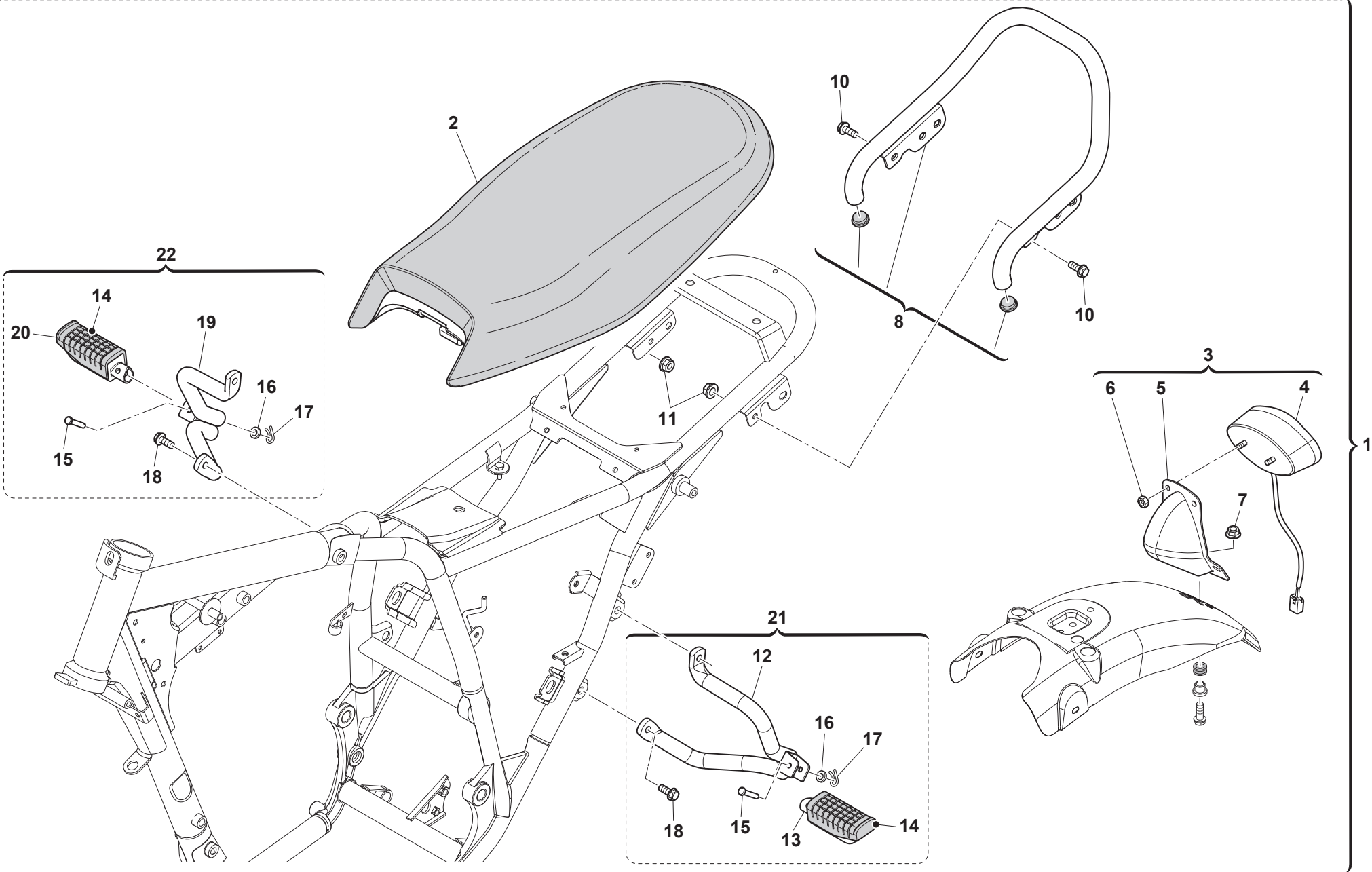



Note Notes Notes Marke Notas	Pos. No. N. Index Pos.	N. Cod. Code No. Nr. Code Code Nr N. Cod.	Q.tà Q.ty Q.te M.ge C.ad	DENOMINAZIONE	NAME	DESIGNATION	BESHREIBUNG	DENOMINACION
	1	F000A00311	1	KIT BIPOSTO	DOUBLE SIT KIT	KIT BIPLACE	SATZ ZWEISITZER	KIT BIPOSTO
	2	F000A00629	1	SELLA BIPOSTO	SADDLE	SELLE	SITZBANK	ASIENTO
	3	32060531	1	FANALE POSTERIORE COMPLETO	COMPLETE TAIL LIGHT	FEU ARRIÈRE COMPLET	HECKSCHEINWERFER KOMPLETT	PILOTO TRASERO COMPLETO
	4	32060503	1	FANALE POSTERIORE	TAIL LIGHT	FEU ARRIÈRE	HECKSCHEINWERFER	PILOTO TRASERO
	5	73220076	1	SUPPORTO FARO POSTERIORE	SUPPORT	SUPPORT	HALTERUNG	SOPORTE
	6	72020507	2	DADO M6	NUT M6	ECROU M6	MUTTER M6	TUERCA M6
	7	Z00061313	3	DADO M6	NUT M6	ECROU M6	MUTTER M6	TUERCA M6
	8	FA00A00821	1	MANIGLIA PASSEGGERO	PASSENGERS HANDLE	POIGNÉE PASSAGER	GRIFF	MANILLA ACOMPAÑANTE
	9	73012255	2	TAPPO Ø22 - Ø19	PLUG Ø22 - Ø19	BOUCHON Ø22 - Ø19	STOPFEN Ø22 - Ø19	TAPON Ø22 - Ø19
	10	Z00069056	2	VITE TEF M8x20	FLANGED EXAGON HEAD SCREW M8x20	BOULON DE BRIDE M8x20	FLANSCHENSCHRAUBE M8x20	TORNILLO DE REBORDE M8x20
	11	Y00043928	2	DADO FRENATO M8	SELF-LOCKING NUT M8	ECROU AUTOBLOQUANT M8	SELBSTSICHERNDE MUTTER M8	TUERCA AUTOBLOCANTE M8
	12	F000P00508	1	SUPPORTO PEDANA SINISTRA	L.H. FOOTREST SUPPORT	SUPPORT REPOSE-PIEDS GAUCHE	HALTERUNG FUßRASTE LINKS	SOPORTE ESTRIBO IZQUIERDA
	13	50718-BA7-9000	1	PEDANA PASSEGGERO SINISTRA	PASSENGER L.H. FOOTREST	REPOSE-PIEDS GAUCHE	FUßRASTE LINKS	ESTRIBO IZQUIERDA
	14	50710-BA7-7700	2	GOMMINO PEDANA	FOOTREST RUBBER	CAOUTCHOUC	GUMMI	GOMA
	15	S5015-81000	2	PERNO	PIN	AXE	BOLZEN	EJE
	16	72040633	2	ROSETTA	WASHER	RONDELLE	UNTERLEGSCHLEIFE	ARANDELA
	17	S7205012	2	COPIGLIA	SPLIT PIN	GOUPILLE	SPLINT	PASADOR
	18	ZA0069056	2	VITE TEF M8x45	FLANGED EXAGON HEAD SCREW M8x45	BOULON DE BRIDE M8x45	FLANSCHENSCHRAUBE M8x45	TORNILLO DE REBORDE M8x45
	19	F000P00507	1	SUPPORTO PEDANA DESTRA	R.H. FOOTREST SUPPORT	SUPPORT REPOSE-PIEDS DROITE	HALTERUNG FUßRASTE RECHTS	SOPORTE ESTRIBO DERECHA
	20	50715-BA7-9000	1	PEDANA PASSEGGERO DESTRA	PASSENGER R.H. FOOTREST	REPOSE-PIEDS DROIT	FUßRASTE RECHTS	ESTRIBO DERECHA
	21	F000A00726	1	ASS. PEDANA PASSEGGERO SINISTRA	PASSENGER L.H. FOOTREST ASSY	REPOSE-PIEDS GAUCHE COMPL.	ZSB. FUßRASTE LINKS	CONJ. ESTRIBO IZQUIERDA
	22	F000A00727	1	ASS. PEDANA PASSEGGERO DESTRA	PASSENGER R.H. FOOTREST ASSY	REPOSE-PIEDS DROIT COMPL.	ZSB. FUßRASTE RECHTS	CONJ. ESTRIBO DERECHA

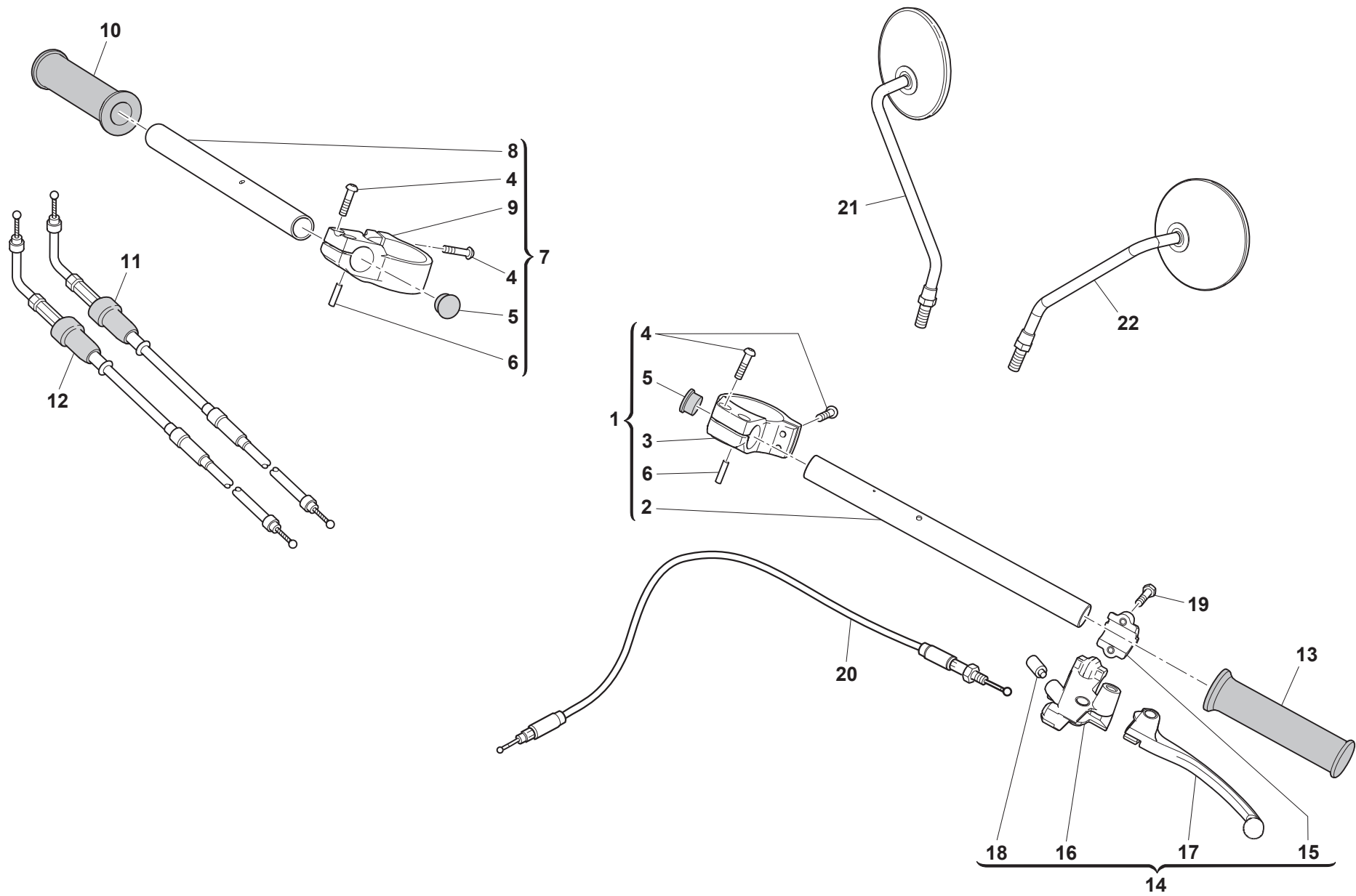

**GRAN MILANO 440**
MANUBRIO E COMANDI - HANDLEBAR AND CONTROLS
GUIDON ET COMMANDES - LENKER UND STEUERORGANE
MANILLAR Y MANDOS
TAVOLA
DRAWING
TABLE
BILD
TABLA**21**

Note Notes Marke Notas	Pos. No. Index Pos.	N. Cod. Code No. Nr. Code Code Nr N. Cod.	Q.tà Q.ty Q.te M.ge C.ad	DENOMINAZIONE	NAME	DESIGNATION	BESHREIBUNG	DENOMINACION
	1	F000A00442	1	SEMIMANUBRIO SINISTRO	L.H. HALF HANDLEBAR	GUIDON GAUCHE	LENKER LINKS	MANILLAR IZQ.
	2	F000P00789	1	TUBO SEMIMANUBRIO SINISTRO	L.H. HALF HANDLEBAR HOSE	TUBE GUIDON GAUCHE	LENKER ROHR LINKS	TUBO MANILLAR IZQ.
	3	F000P00790	1	BRACCIALETTO SEMIMANUBRIO SX	L.H. HALF HANDLEBAR BRACKET	ETRIER GUIDON GAUCHE	BÜGEL LINKS	ESTRIBO IZQ.
	4	800061070	8	VITE TBEI M6x25	BOLT TBEI M6x25	VIS TBEI M6x25	SCHRAUBE TBEI M6x25	TORNILLO TBEI M6x25
	5	F000P00791	2	TAPPO	PLUG	BOUCHON	STOPFEN	TAPON
	6	F000P00869	2	PERNO	PIN	AXE	BOLZEN	EJE
	7	F000A00443	1	SEMIMANUBRIO DESTRO	R.H. HALF HANDLEBAR	GUIDON DROIT	LENKER RECHTS	MANILLAR DER.
	8	F000P00792	1	TUBO SEMIMANUBRIO DX	R.H. HALF HANDLEBAR HOSE	TUBE GUIDON DROIT	LENKER ROHR RECHTS	TUBO MANILLAR DER.
	9	F000P00793	1	BRACCIALETTO SEMIMANUBRIO DX	R.H. HALF HANDLEBAR BRACKET	ETRIER GUIDON DROIT	BÜGEL RECHTS	ESTRIBO DER.
	10	F000A00883	1	COMANDO GAS COMPLETO	COMPLETE THROTTLE CONTROL	COMMANDE DES GAZ COMPLÈTE	GASZUG KOMPLETT	MANDO ACELERADOR COMPLETO
	11	47030328	1	CAVO ACCELERATORE	CABLE ASSY, THROTTLE	CÂBLE COMMANDE DES GAZ	KABEL GASZUG	CABLE ACELERADOR
	12	F000A00796	1	ASSIEME CAVO ACCEL. CON PIASTRINA	CABLE ASSY THROTTLE WITH CLAMP	CÂBLE COMM. DES GAZ COMPLÈTE	KABEL GASZUG KOMPLETT	CABLE ACELERADOR COMPLETO
	13	45060104	1	MANOPOLA SINISTRA	L.H. HANDGRIP	POIGNÉE GAUCHE	GRIFF LINKS	PUÑO IZQUIERDA
	14	F000A00776	1	ASSIEME COMANDO FRIZIONE	CLUTCH CONTROL ASSY	COMMANDE EMBRAYAGE COMPL.	ZUSAMMENBAU KUPPLUNGSZUG	CONJUNTO MANDO EMBRAGUE
	15	F000P00828	1	CAVALLOTTO	CLAMP	BOULON	BÜGELSCHRAUBE	CABALLETE
	16	F000P00829	1	SUPPORTO	SUPPORT	SUPPORT	HALTERUNG	SOPORTE
	17	F000P00830	1	LEVA FRIZIONE	CLUTCH LEVER	LEVIER EMBRAYAGE	KUPPLUNGSHEBEL	PALANCA EMBRAGUE
	18	45530027	1	INTERRUTTORE LEVA FRIZIONE	CLUTCH LEVER SWITCH	INTER. LEVIER EMBRAYAGE	KUPPLUNGSCHALTER	INTER.PALANCAEMBRAGUE
	19	Z00062728	2	VITE TEF M6x20	FLANGED EXAGON HEAD SCREW M6x20	BOULON DE BRIDE M6x20	SCHRAUBE M6x20	TORNILLO M6x20
	20	F000P01180	1	CAVO FRIZIONE	CLUTCH CABLE	CÂBLE	KABEL	CABLE
	21	53230291	1	SPECCHIETTO RETROV. DX	R.H. REAR-VIEW MIRROR	RÉTROVISEUR DROITE	RÜCKSPIEGEL RECHTS	ESPEJO RETROV. DER.
	22	53240279	1	SPECCHIETTO RETROV. SX	L.H. REAR-VIEW MIRROR	RÉTROVISEUR GAUCHE	RÜCKSPIEGEL LINKE	ESPEJO RETROV. IZQ.

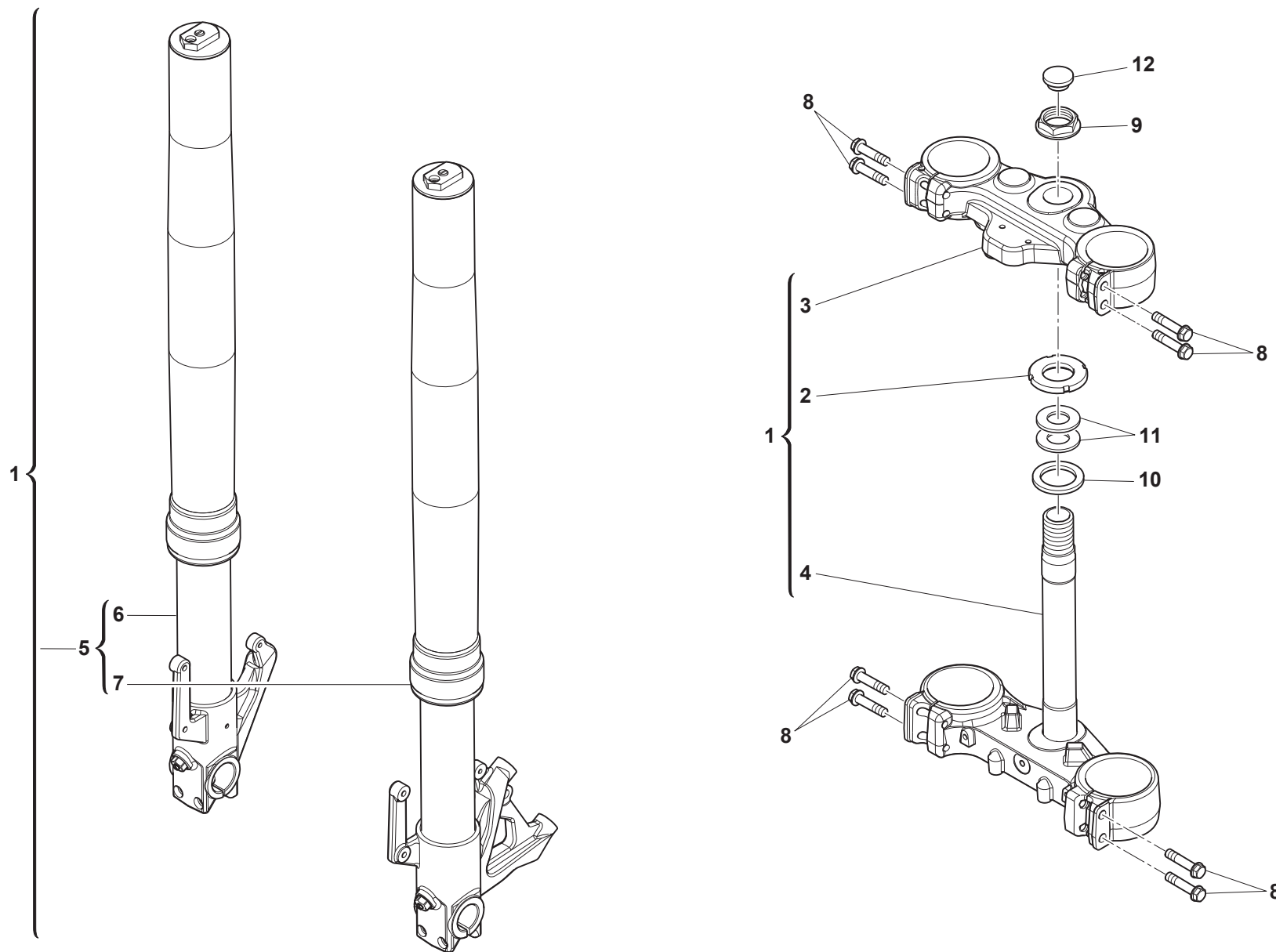

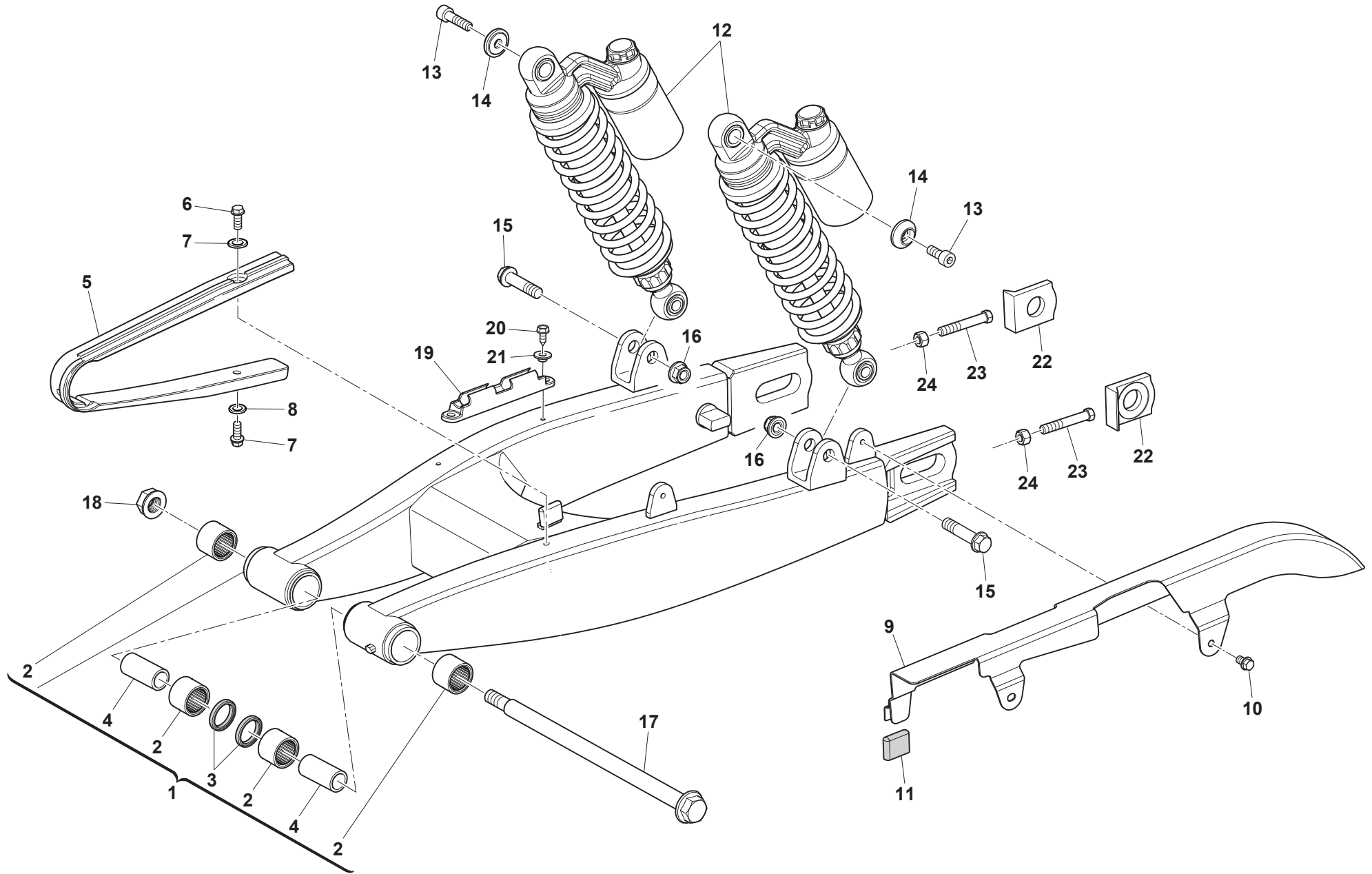

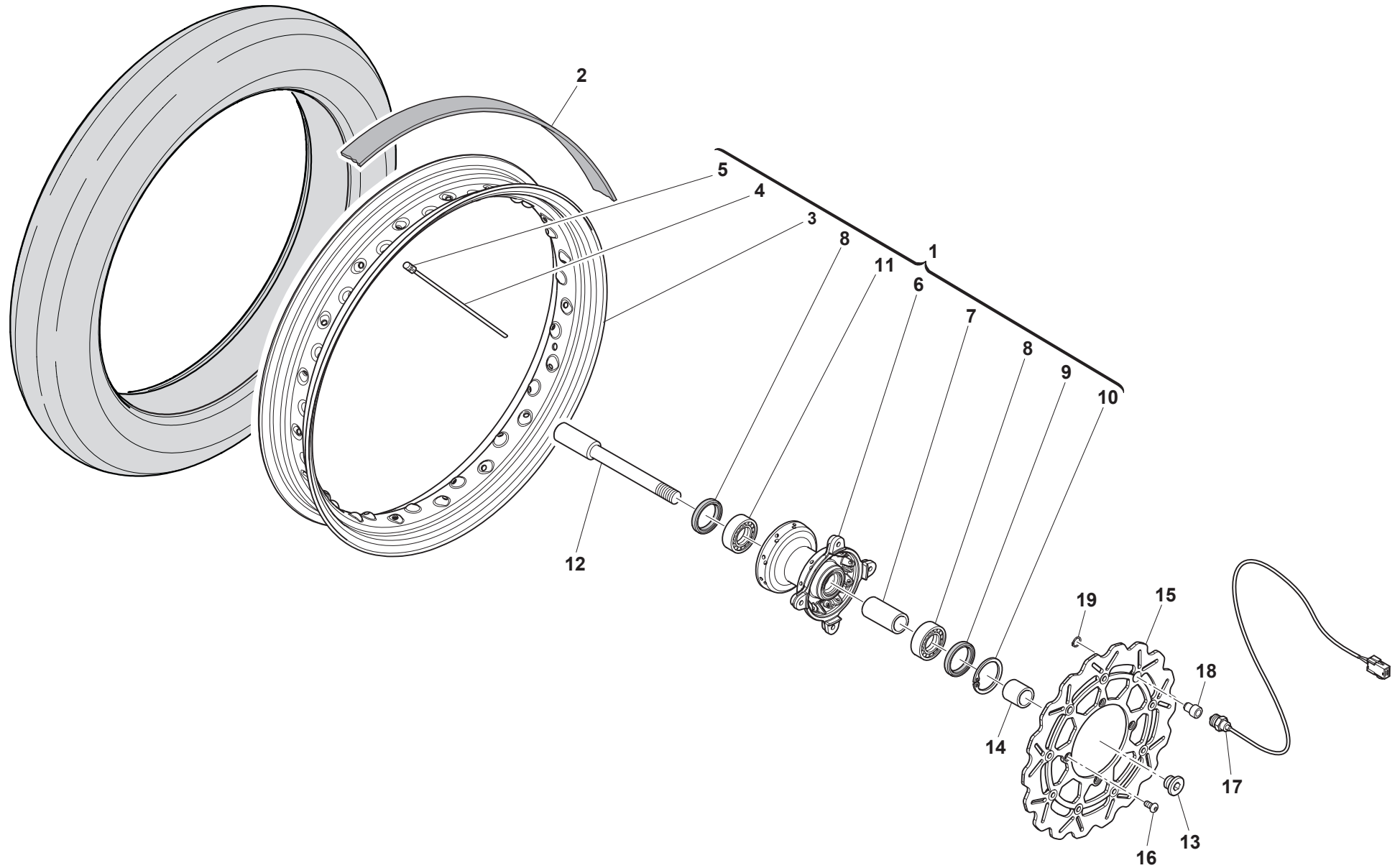

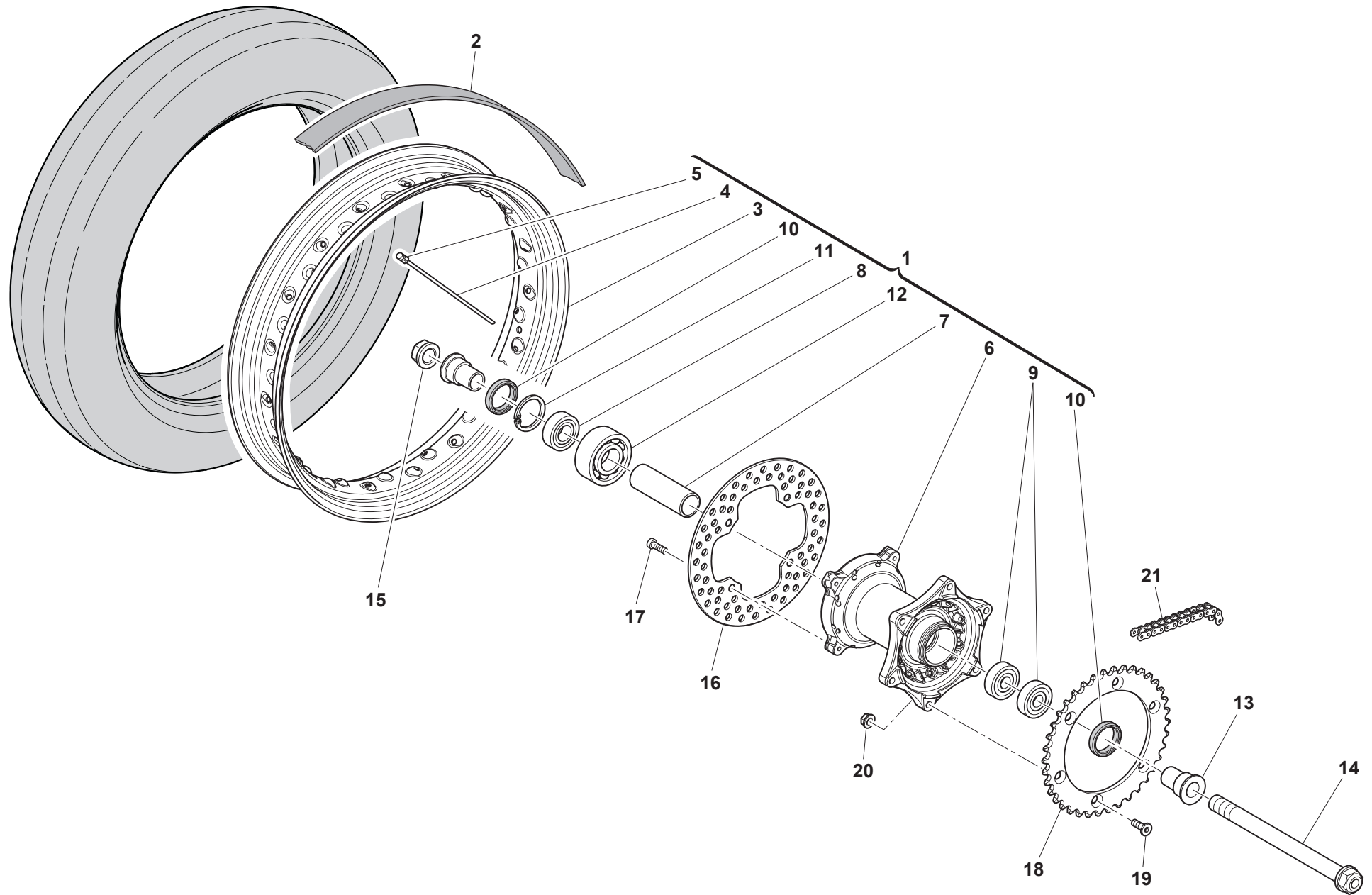



GRAN MILANO 440

RUOTA POSTERIORE - REAR WHEEL ROUE ARRIERE - HINTERRAD RUEDA TRASERA

TAVOLA
DRAWING
TABLE
BILD
TABLA

25

Note Notes Notes Marke Notas	Pos. No. Index Pos.	N. Cod. Code No. Nr. Code Code Nr N. Cod.	Q.tà Q.ty Q.te M.ge C.ad	DENOMINAZIONE	NAME	DESIGNATION	BESHREIBUNG	DENOMINACION
	1	FA00A00126	1	RUOTA POSTERIORE COMPLETA	REAR WHEEL ASSY	ROUE ARRIÈRE COMPLÈTE	HINTERRAD KOMPLETT	RUEDA TRASERA COMPLETA
	2	8B0082879	1	PROTEZIONE CAMERA D'ARIA	AIR TUBE PROTECTION	VAINE DE PROTECTION	HULLE	VAINA DE PROTECCION
	3	FOA0P00262	1	CERCHIO RUOTA POST. 4,25"x17"	REAR WHEEL RIM 4,25"x17"	JANTE ROUE ARRIÈRE 4,25"x17"	FELGE HINTERRAD 4,25"x17"	LLANTA RUEDA TRAS. 4,25"x17"
	4	8000H1725	18	RAGGIO	SPOKE	BRAS	SPEICHE	RADIO
	4	8000H1726	18	RAGGIO	SPOKE	BRAS	SPEICHE	RADIO
	5	69N429005	36	NIPPLO	NIPPLE	NIPPLE	NIPPEL	NIPLE
	6	FA00P00094	1	MOZZO RUOTA POSTERIORE	REAR WHEEL HUB	MOYEU	NABE	CUBO
	7	800092414	1	DISTANZIALE INTERNO	INTERNAL SPACER	ENTRETOISE INTÉRIEUR	INTERNER ABSTANDHALTER	DISTANCIADOR INTERNO
	8	8B0026846	1	CUSCINETTO A SFERE Ø25x47x16	BALL BEARING Ø25x47x16	ROULEMENT À BILLES Ø25x47x16	KUGELLAGER Ø25x47x16	COJINETE DE BOLAS Ø25x47x16
	9	8A0026846	2	CUSCINETTO RADIALE	RADIAL BALL BEARING	ROULEMENT	LAGER	COJINETE
	10	800089572	2	ANELLO Ø47x32x7	RING Ø47x32x7	BAGUE Ø47x32x7	RING Ø47x32x7	ANILLO Ø47x32x7
	11	66N021272	1	ANELLO ELASTICO Ø50,5xSP1,75	CIRCLIP Ø50,5xTHK1,75	CIRCLIP Ø50,5xSP1,75	SPRENGRING Ø50,5xSP1,75	ANILLO ELASTICO Ø50,5xSP1,75
	12	F000P00121	1	PORTA DISTANZIALE	INNER SPACER SUPPORT	ENTRETOISE	ABSTANDHALTER	DISTANCIADOR
	13	F000P00713	2	DISTANZIALE ESTERNO	EXTERNAL SPACER	ENTRETOISE	ABSTANDHALTER	DISTANCIADOR
	14	70080069	1	PERNO RUOTA POSTERIORE	WHEEL AXLE	PIVOT DE ROUE	RADASCHE	EJE RUEDA
	15	72020318	1	DADO M20	NUT M20	ECROU M20	MUTTER M20	TUERCA M20
	16	800088887	1	DISCO FRENO POSTERIORE	REAR BRAKE DISC	DISQUE DE FREIN	BREMSSCHEIBE	DISCO FRENO
	17	800055878	4	VITE M6x11	SCREW M6x11	VIS M6x11	SCHRAUBE M6x11	TORNILLO M6x11
	18	8H0085291	1	CORONA DENTATA Z=40	CHAIN SPROCKET T=40	COURONNE DENTÉE D=40	ZAHNKRANZ Z=40	CORONA DENTADA Z=40
	19	8000H0158	6	VITE SPECIALE TSEI M8x28	SPECIAL SCREW TSEI M8x28	VIS TSEI M8x28	SCHRAUBE TSEI M8x28	TORNILLO TSEI M8x28
	20	Y00043928	6	DADO FLANGIATO M8	FLANGED NUT M8	ECROU BRIDE M8	FLANSCHMUTTER M8	TUERCA CON BRIDA M8
	21	F000P01134	1	CATENA 110 MAGLIE	CHAIN,110 PITCHES	CHAÎNE 110 MAILLONS	KETTE 110 GLIEDER	CADENA 110 ESLABONES

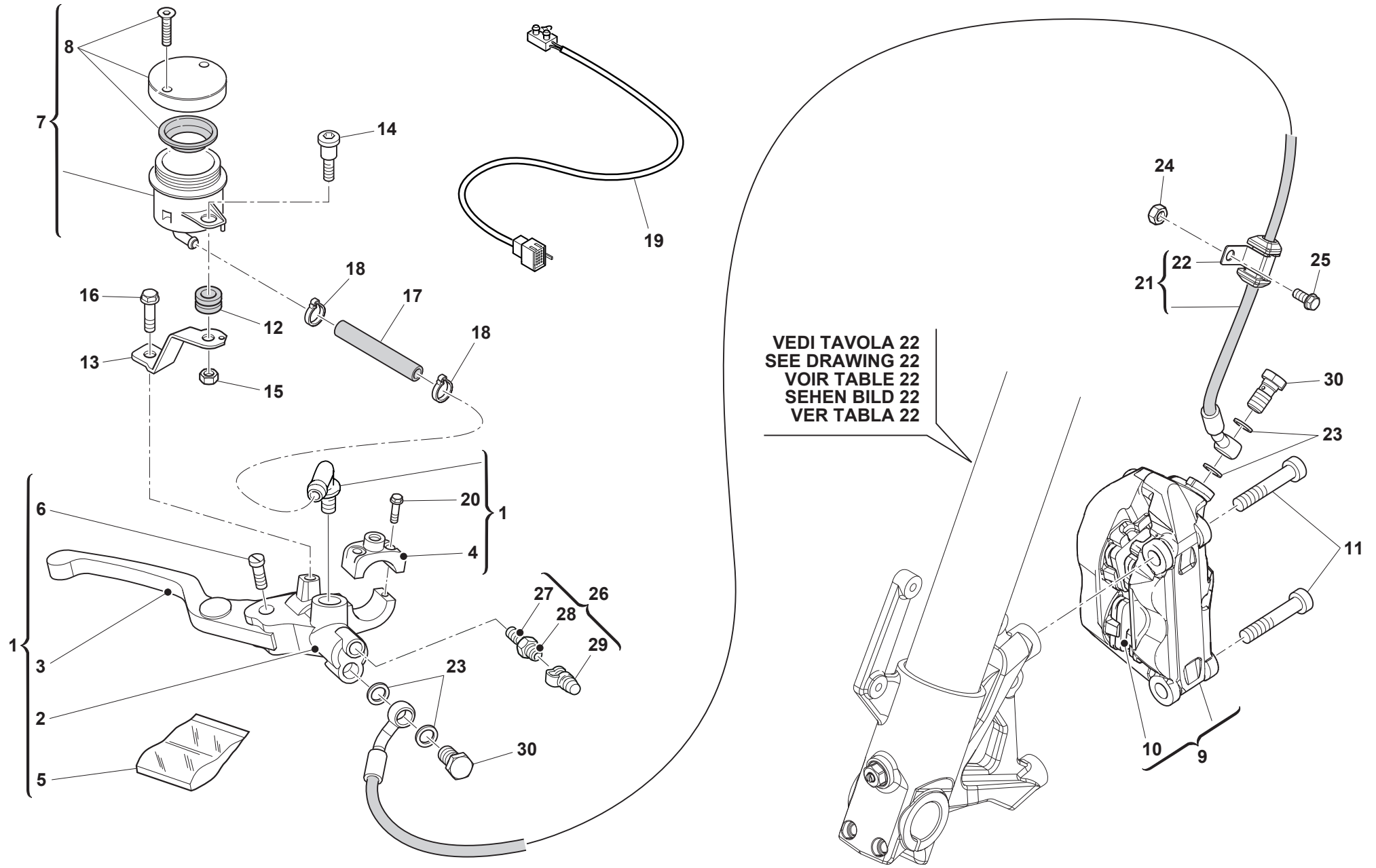



GRAN MILANO 440

FRENO IDRAULICO ANTERIORE - FRONT HYDRAULIC BRAKE FREIN HYDRAULIQUE AVANT - VORDERBREMSE FRENO HIDRAULICO DELANTERO

TAVOLA
DRAWING
TABLE
BILD
TABLA

26

Note Notes Notes Marke Notas	Pos. No. N. Index Pos.	N. Cod. Code No. Nr. Code Code Nr N. Cod.	Q.tà Q.ty Q.te M.ge C.ad	DENOMINAZIONE	NAME	DESIGNATION	BESHREIBUNG	DENOMINACION
	1	8000A6075	1	ASSIEME POMPA FRENO ANTERIORE	MASTER CYLINDER ASSY	MAÎTRE-CYLINDRE DE FREIN COMPL.	ZUSAMMENBAU HAUPTBREMSZYLINDER	CONJUNTO BOMBA FRENO
	2	8000A6076	1	POMPA FRENO ANTERIORE	FRONT MASTER CYLINDER	MAÎTRE-CYLINDRE DE FREIN AVANT	HAUPTBREMSZYLINDER VORNE	BOMBA FRENO DELANTERO
	3	8000A7146	1	LEVA FRENO ANTERIORE	FRONT BRAKE LEVER	LEVIER	HEBEL	PALANCA
	4	8000A7147	1	CAVALLOTTO	CLAMP	BOULON	BÜGELSCHRAUBE	CABALLETE
	5	800042345	1	KIT REVISIONE RACCORDO	CONNECTION SET	GROUPE DE RÉVISION RACCORD	ANSCHLUSSSATZ	GRUPO REVISIÓN RACOR
	6	8000A7148	1	PERNO	PIN	AXE	BOLZEN	EJE
	7	800066181	1	SERBATOIO OLIO	OIL TANK	RÉSERVOIR D'HUILE	ÖLBEHÄLTER	DEPÓSITO ACEITE
	8	800068490	1	KIT REVISIONE TAPPO	REVISION KIT	GROUPE DE REVISION BOUCHON	STOPFENSATZ	GRUPO REVISION TAPON
	9	80A0A6078	1	PINZA FRENO ANTERIORE	FRONT BRAKE CALLIPER	ETRIER DE FREIN AVANT	BREMSSATTEL VORDERR	PINZA FRENO DELANTERO
	10	8A00A2040	1	COPPIA PASTIGLIE	PAIR OF BRAKE PADS	PAIRE PLAQUETTES	PAAR BREMSBELÄGE	PAREJA PASTILLAS
	11	YS0082751	2	VITE TCEIF M10x55	SCREW TCEIF M10x55	VIS TCEIF M10x55	SCHRAUBE TCEIF M10x55	TORNILLO TCEIF M10x55
	12	800033288	1	GOMMINO ANTIVIBRANTE	SILENT-BLOCK	ANTIVIBRATION	SCHWINGUNGSDAMFER	ANTIVIBRADOR
	13	8000A6229	1	PIASTRINA	PLATE	PLAQUETTE	PLÄTTCHEN	PLACA
	14	8000A1189	1	VITE	BOLT	VIS	SCHRAUBE	TORNILLO
	15	Z00056443	1	DADO AUTOBLOCCANTE M5	SELF-LOCKING NUT M5	ECROU AUTOBLOQUANT M5	SELBSTSICHERNDE MUTTER M5	TUERCA AUTOBLOCANTE M5
	16	Z00062725	1	VITE TEF M6x10	FLANGED EXAGON HEAD SCREW M6x10	BOULON DE BRIDE M6x10	FLANSCHENSCHRAUBE M6x10	TORNILLO DE REBORDE M6x10
	17	8G0066179	1	TUBO IN GOMMA L= 60 mm	PIPE L= 60 mm	TUBE L= 60 mm	ROHR L= 60 mm	TUBO L= 60 mm
	18	800018921	2	ANELLO ELASTICO	CIRCLIP	CIRCLIP	SPRENGRING	ANILLO ELASTICO
	19	8000A0929	1	INTERRUTTORE POMPA FRENO	FRONT BRAKE PUMP SWITCH	INTERRUPTEUR DE FREIN	SCHALTER	INTERRUPTOR FRENO
	20	Z00062729	2	VITE TEF M6x25	FLANGED EXAGON HEAD SCREW M6x25	BOULON DE BRIDE M6x25	FLANSCHENSCHRAUBE M6x25	TORNILLO DE REBORDE M6x25
	21	F000A00649	1	TUBO FRENO ANTERIORE	FRONT BRAKE HOSE	TUYAU DE FREIN AVANT	ROHR VORDERRADBREMSE	TUBO FRENO DELANTERO
	22	73032259	2	FASCETTA	CLAMP	COLLIER	SHELLE	ABRAZADERA
	23	800021480	4	ROSETTA	WASHER	RONDELLE	UNTERLEGSCHLEIBE	ARANDELA
	24	Z00061355	1	DADO AUTOBLOCCANTE M5	SELF-LOCKING NUT M5	ECROU AUTOBLOQUANT M5	SELBSTSICHERNDE MUTTER M5	TUERCA AUTOBLOCANTE M5
	25	ZA0067997	1	VITE TEF M5x16	FLANGED EXAGON HEAD SCREW M5x16	BOULON DE BRIDE M5x16	FLANSCHENSCHRAUBE M5x16	TORNILLO DE REBORDE M5x16
	26	8000A3975	1	BOCCHETTONE SPURGO COMPLETO	COMPLETE BLEED FILLER	ORIFICE DE PURGE COMPLET	ENTLÜFTUNGSSTUTZEN KOMPLETT	BOCA PURGA COMPLETA
	27	8000A3976	1	BOCCHETTONE SPURGO	BRAKE OIL PIPE SCREW	ORIFICE DE PURGE	ENTLÜFTUNGSSTUTZEN	BOCA PURGA
	28	8000A3977	1	VALVOLA DI SPURGO	BLEEDING OIL VALVE	ROBINET DE PURGE	ENTLÜFTUNGSVENTIL	VÁLVULA DE PURGA
	29	800053259	1	PARAPOLVERE	DUST SEAL	CACHE-POUSSIÈRES	STAUBSCHUTZ	GUARDAPOLVO
	30	U00057155	2	VITE TE M10x19	HEXAGON SOCKET-HEAD BOLT M10x19	VIS M10x19	SCHRAUBE M10x19	TORNILLO M10x19

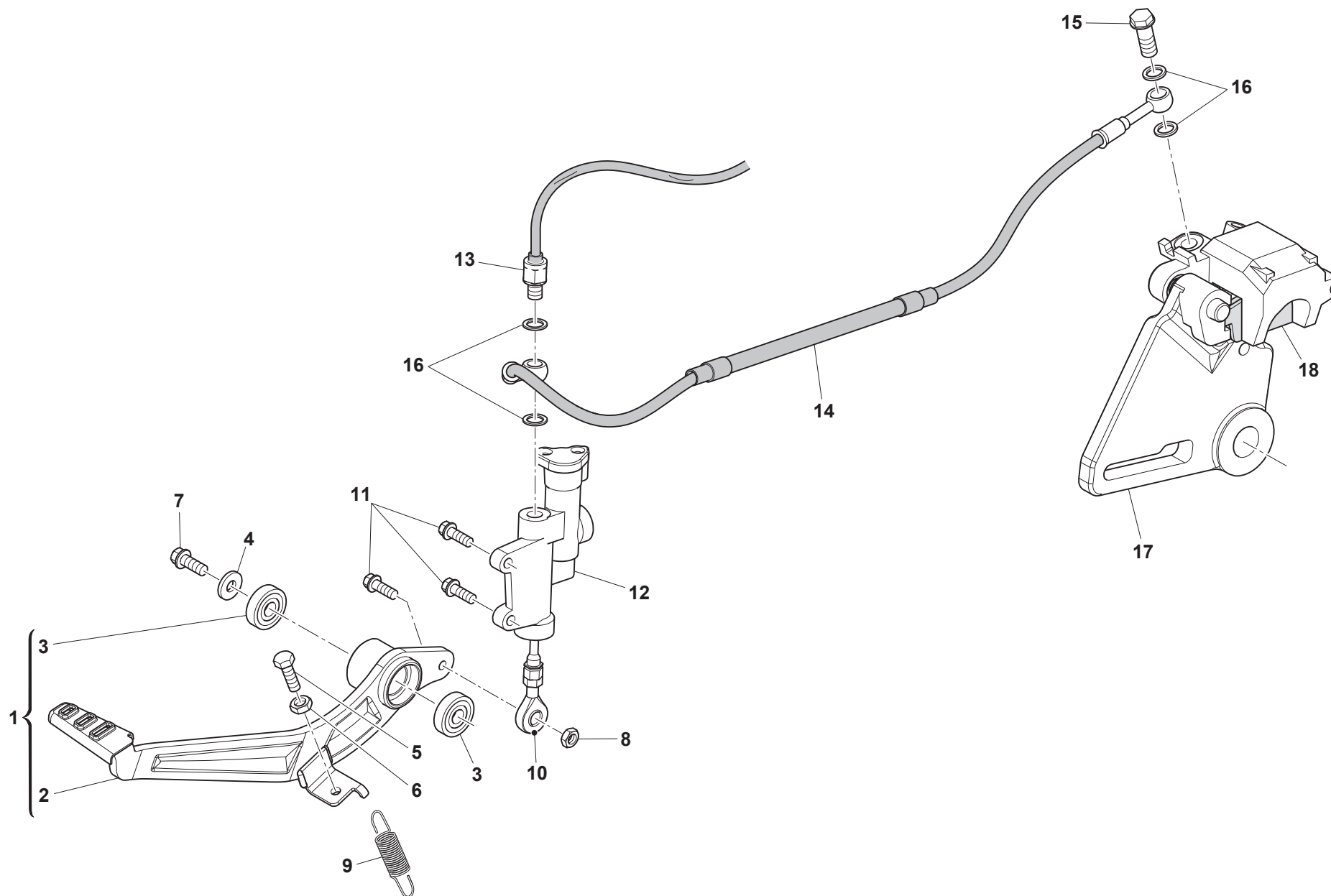



FRENO IDRAULICO POSTERIORE - REAR HYDRAULIC BRAKE
 FREIN HYDRAULIQUE ARRIERE - HINTERBREMSE
 FRENO HIDRAULICO TRASERO

Note Notes Notes Marke Notas	Pos. No. Index Pos.	N. Cod. Code No. Nr. Code Code Nr N. Cod.	Q.tà Q.ty Q.te M.ge C.ad	DENOMINAZIONE	NAME	DESIGNATION	BESHREIBUNG	DENOMINACION
	1	F000A00513	1	PEDALE COMANDO FRENO	BRAKE CONTROL PEDAL	PÉDALE COMMANDE DE FREIN	BREMSPEDAL	PEDAL MANDO FRENO
	2	F000P00514	1	LEVA FRENO	BRAKE LEVER	LEVIER	HEBEL	PALANCA
	3	70090215	2	CUSCINETTO 6900	BEARING 6900	ROULEMENT 6900	LAGER 6900	COJINETE 6900
	4	Z00045499	1	ROSETTA	WASHER	RONDELLE	UNTERLEGSSCHEIBE	ARANDELA
	5	60ND01081	1	VITE TE M6x25	HEXAGON SOCKET-HEAD BOLT M6x25	VIS M6x25	SCHRAUBE M6x25	TORNILLO M6x25
	6	61ND15033	1	DADO M6	NUT M6	ECROU M6	MUTTER M6	TUERCA M6
	7	Z00062727	1	VITE TEF M6x16	FLANGED EXAGON HEAD SCREW M6x16	BOULON DE BRIDE M6x16	FLANSCHENSCHRAUBE M6x16	TORNILLO DE REBORDE M6x16
	8	Z00061313	1	DADO M6	NUT M6	ECROU M6	MUTTER M6	TUERCA M6
	9	F000P00834	1	MOLLA PEDALE FRENO	RETURN SPRING	RESSORT	FEDER	MUELLE
	10	55120292	1	PUNTALE	PUSH ROD	EMBOUT	STIFT	PUNTA
	11	Z00062728	3	VITE TEF M6x20	FLANGED EXAGON HEAD SCREW M6x20	BOULON DE BRIDE M6x20	SCHRAUBE M6x20	TORNILLO M6x20
	12	55120355	1	POMPA FRENO POSTERIORE	REAR BRAKE PUMP	MAÎTRE-CYLINDRE DE FREIN	ZUSAMMENBAU HAUPTBREMSZYLINDER	CONJUNTO BOMBA FRENO
	13	31240061	1	INTERRUTTORE FRENO POSTERIORE	REAR BRAKE SWITCH	INTERRUPTEUR DE FREIN	SCHALTER	INTERRUPTOR FRENO
	14	F000P01002	1	TUBO FRENO POSTERIORE	REAR BRAKE TUBE	TUYAU DE FREIN ARRIÈRE	ROHR HINTERRADBREMSE	TUBO FRENO TRASERO
	15	72012148	1	VITE FORATA M10x1,25	SCREW M10x1,25	VIS M10x1,25	SCHRAUBE M10x1,25	TORNILLO M10x1,25
	16	800021480	4	ROSETTA	WASHER	RONDELLE	UNTERLEGSSCHEIBE	ARANDELA
	17	F000A00455	1	PINZA FRENO POSTERIORE	REAR BRAKE CALLIPER	ETRIER DE FREIN ARRIERE	BREMSSATTEL HINT.	PINZA FRENO TRASERO
	18	55110053	1	COPPIA PASTIGLIE	PAIR OF BRAKE PADS	PAIRE PLAQUETTES	PAAR BREMSBELÄGE	PAREJA PASTILLAS

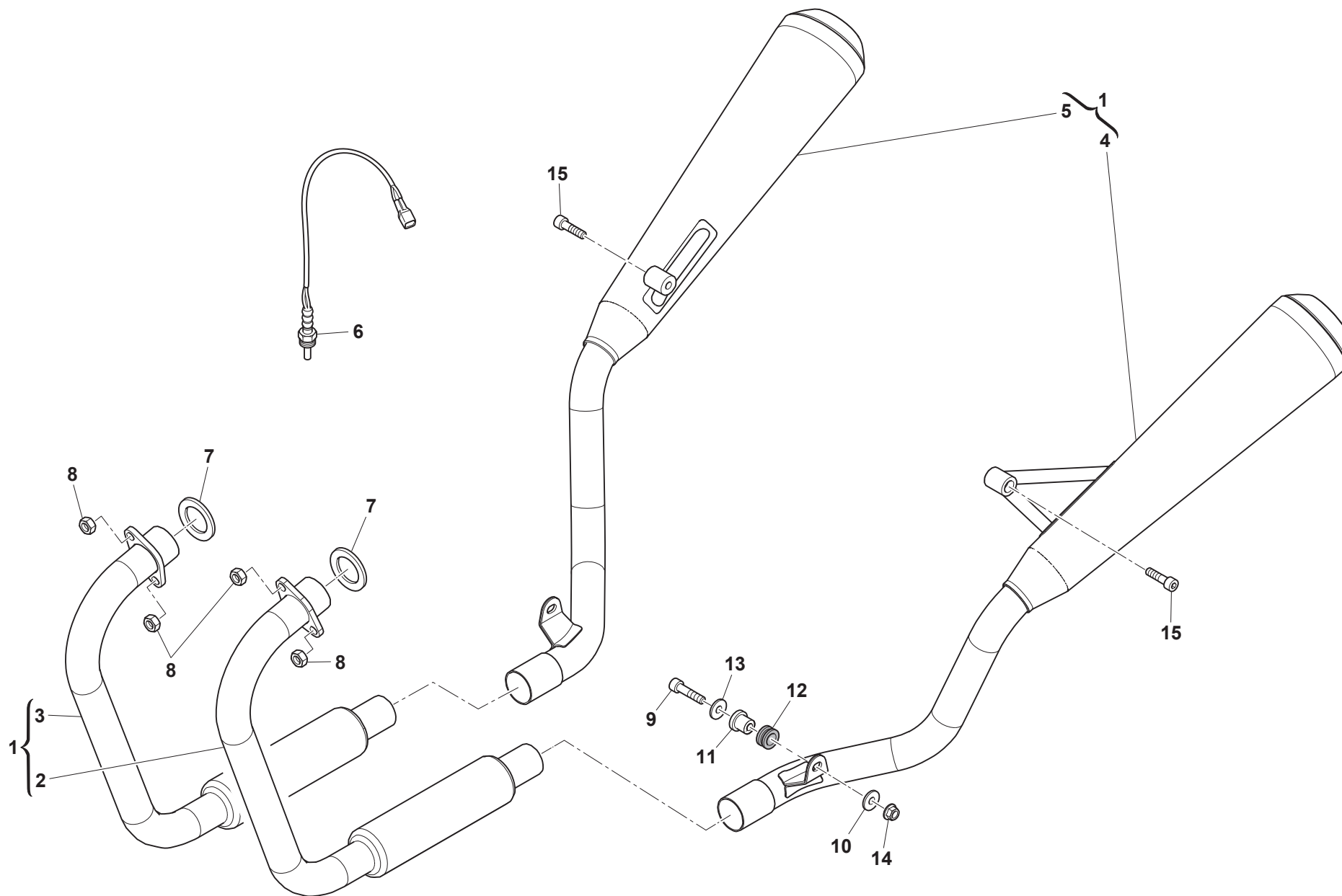



GRAN MILANO 440

SCARICO - EXHAUST SYSTEM
TUYAU D'ECHAPPEMENT - AUSPUFFROHR
TUBO DE ESCAPE

TAVOLA
 DRAWING
 TABLE
 BILD
 TABLA

28

Note Notes Notes Marke Notas	Pos. No. Index Pos.	N. Cod. Code No. Nr. Code Code Nr N. Cod.	Q.tà Q.ty Q.te M.ge C.ad	DENOMINAZIONE	NAME	DESIGNATION	BESHREIBUNG	DENOMINACION
	1	F000A00458	1	ASS. IMPIANTO DI SCARICO	EXHAUST SYSTEM ASSY	INSTALLATION DE ECHAPPEMENT	AUSPUFFROHR KOMPLETT	EQUIPO DE ESCAPE
	2	F000A00683	1	COLLETTORE DI SCARICO SX	LEFT EXHAUST MUFFLER	COLLECTEUR GAUCHE	KRÜMMER LINKE	COLECTOR IZQ.
	3	F000A00684	1	COLLETTORE DI SCARICO DX	RIGHT EXHAUST MUFFLER	COLLECTEUR DROITE	KRÜMMER RECHTS	COLECTOR DER.
	4	F000A00638	1	SILENZIATORE SINISTRO	L.H. SILENCER	SILENCIEUX GAUCHE	SCHALLDÄMPFER LINKS	SILENCIADOR IZQ.
	5	F000A00639	1	SILENZIATORE DESTRO	R.H. SILENCER	SILENCIEUX DROIT	SCHALLDÄMPFER RECHTS	SILENCIADOR DER.
	6	F000P00856	1	SONDA LAMBDA	LAMBDA SENSOR	SONDE LAMBDA	LAMBDA-SONDE	SONDA LAMBDA
	7	18140216	2	GUARNIZIONE SCARICO	SEAL RING, MUFFLER	JOINT	DICHTUNG	JUNTA
	8	72020492	4	DADO M8	NUT M8	ECROU M8	MUTTER M8	TUERCA M8
	9	60ND02558	2	VITE TCEI M8x35	SCREW TCEI M8x35	VIS TCEI M8x35	SCHRAUBE TCEI M8x35	TORNILLO TCEI M8x35
	10	62ND15506	2	ROSETTA	WASHER	RONDELLE	UNTERLEGSscheIBE	ARANDELA
	11	72040549	2	DISTANZIALE	SPACER	ENTRETOISE	ABSTANDHALTER	DISTANCIADOR
	12	73012323	2	GOMMINO	RUBBER RING	JOINT EN CAOUTCHOUC	GUMMISCHEIBE	GOMA
	13	72040604	2	RONDELLA	WASHER	RONDELLE	UNTERLEGSscheIBE	ARANDELA
	14	Y00043928	2	DADO FRENATO M8	SELF-LOCKING NUT M8	ECROU AUTOBLOQUANT M8	SELBSTSICHERNDE MUTTER M8	TUERCA AUTOBLOCANTE M8
	15	60ND02557	2	VITE TCEI M8x30	SCREW TCEI M8x30	VIS TCEI M8x30	SCHRAUBE TCEI M8x30	TORNILLO TCEI M8x30

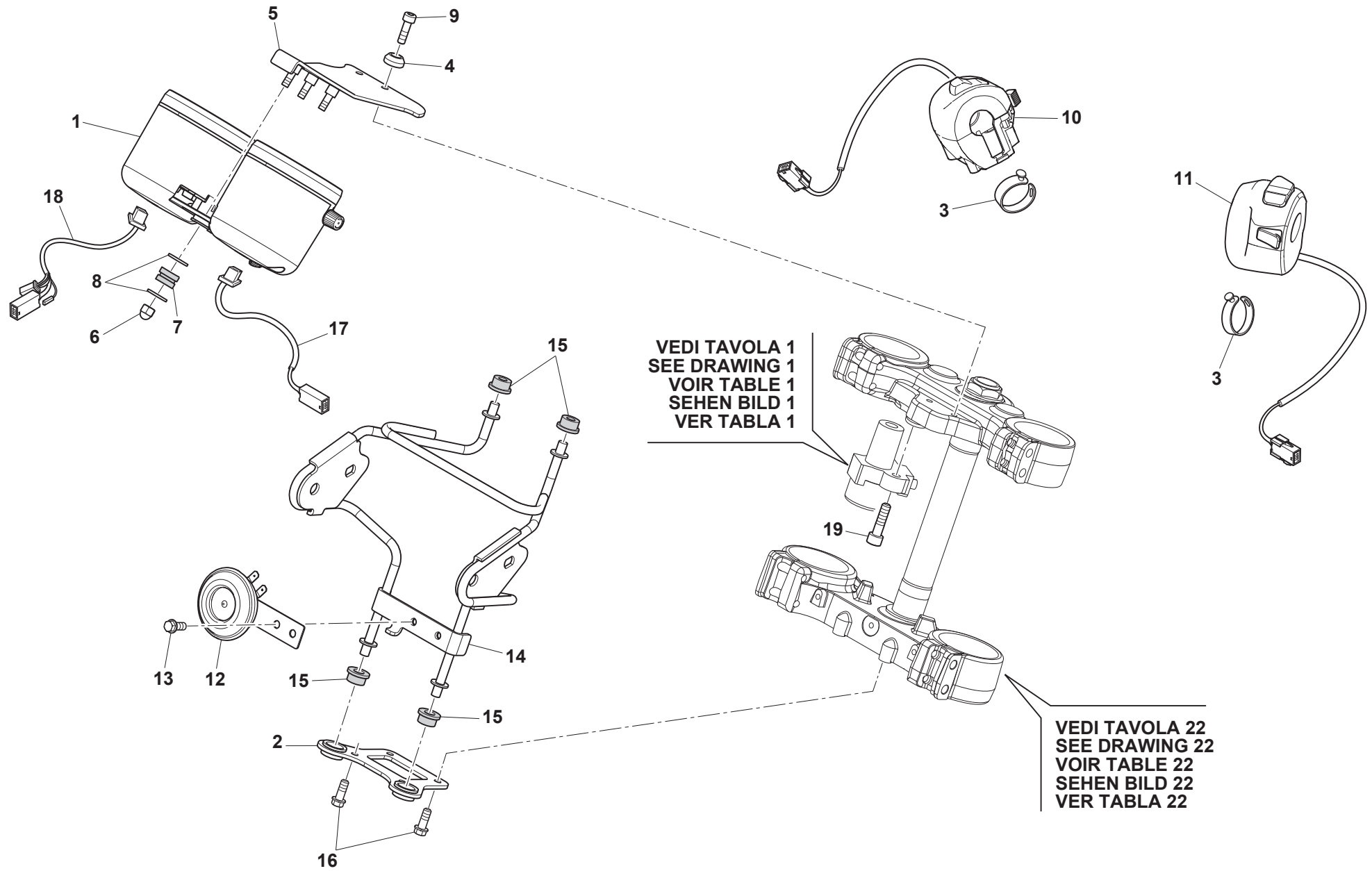



GRAN MILANO 440

STRUMENTO DIGITALE - DIGITAL INSTRUMENT INSTRUMENT DIGITAL - DIGITAL TACHOMETER INSTRUMENTO DIGITAL

TAVOLA
DRAWING
TABLE
BILD
TABLA

29

Note Notes Notes Marke Notas	Pos. No. Index Pos.	N. Cod. Code No. Nr. Code Code Nr N. Cod.	Q.tà Q.ty Q.te M.ge C.ad	DENOMINAZIONE	NAME	DESIGNATION	BESHREIBUNG	DENOMINACION
	1	F0A0A00545	1	ASSIEME STRUMENTO	INSTRUMENT ASSY	INSTRUMENT ENSEMBLE	ZUSAMMENBAU INSTRUMENT	CONJUNTO INSTRUMENTO
	2	F000P00472	1	STAFFA FARO INFERIORE	BRACKET	ETRIER	BÜGEL	ESTRIBO
	3	800092668	5	FASCETTA IN GOMMA L= 25 mm	RUBBER CLAMP L= 25 mm	COLLIER EN CAOUTCHOUC L= 25 mm	GUMMISCHELLE L= 25 mm	ABRAZADERA DE GOMA L= 25 mm
	4	F000P00768	2	RONDELLA CONICA	CONIC SPACER	RONDELLE CONIQUE	UNTERLEGSSCHEIBE	ARANDELA CONICA
	5	F000P00460	1	STAFFA	BRACKET	ETRIER	BÜGEL	ESTRIBO
	6	72020507	3	DADO M6	NUT M6	ECROU M6	MUTTER M6	TUERCA M6
	7	73012155	3	GOMMINO ANTIVIBRANTE	SILENT-BLOCK	ANTIVIBRATION	SCHWINGUNGSDAMFER	ANTIVIBRADOR
	8	Z00021535	6	ROSETTA Ø18x6x1,5	WASHER Ø18x6x1,5	RONDELLE Ø18x6x1,5	UNTERLEGSSCHEIBE Ø18x6x1,5	ARANDELA Ø18x6x1,5
	9	60ND02509	2	VITE TCEI M6x20	SCREW TCEI M6x20	VIS TCEI M6x20	SCHRAUBE TCEI M6x20	TORNILLO TCEI M6x20
	10	F000A00888	1	COMMUTATORE DESTRO	RIGHT SWITCH	COMMUTATEUR DROIT	UMSCHALTER RECHTS	CONMUTADOR DERECHO
	11	36020246	1	COMMUTATORE SINISTRO	LEFT HANDLE SWITCH	COMMUTATEUR GAUCHE	UMSCHALTER LINKS	CONMUTADOR IZQUIERDO
	12	31080131	1	AVVISATORE ACUSTICO	HORN	AVERTISSEUR SONORE	HUPE	AVISADOR ACÚSTICO
	13	ZH0067545	1	VITE TEF M6x12	FLANGED EXAGON HEAD SCREW M6x12	BOULON DE BRIDE M6x12	FLANSCHENSCHRAUBE M6x12	TORNILLO DE REBORDE M6x12
	14	F000P00487	1	TELAIETTO DI SOSTEGNO	HEAD LIGHT FRAME	SOUS-CHÂSSIS DE SUPPORT	STÜTZRAHMEN	SUBCHASIS DE SUJECIÓN
	15	73012327	4	GOMMINO	RUBBER RING	JOINT EN CAOUTCHOUC	GUMMISCHNEIBE	GOMA
	16	Z00062726	4	VITE TEF M6x14	FLANGED EXAGON HEAD SCREW M6x14	BOULON DE BRIDE M6x14	FLANSCHENSCHRAUBE M6x14	TORNILLO DE REBORDE M6x14
	17	E000P01412	1	CAVO PER CONTACHILOMETRI	ODOMETER CABLE	CÂBLE POUR COMPTEUR KILOMÉTRIQUE	KABEL FÜR ODOMETER	CABLE DEL CUENTAKILÓMETROS
	18	E000P01413	1	CAVO PER CONTAGIRI	REV COUNTER CABLE	CÂBLE POUR COMPTE-TOURS	KABEL FÜR DREHZAHLMESSER	CABLE DEL CUENTAVUeltas
	19	60ND02555	2	VITE TCEI M8x20	SCREW TCEI M8x20	VIS TCEI M8x20	SCHRAUBE TCEI M8x20	TORNILLO TCEI M8x20

VEDI TAVOLA 29
SEE DRAWING 29
VOIR TABLE 29
SEHEN BILD 29
VER TABLA 29

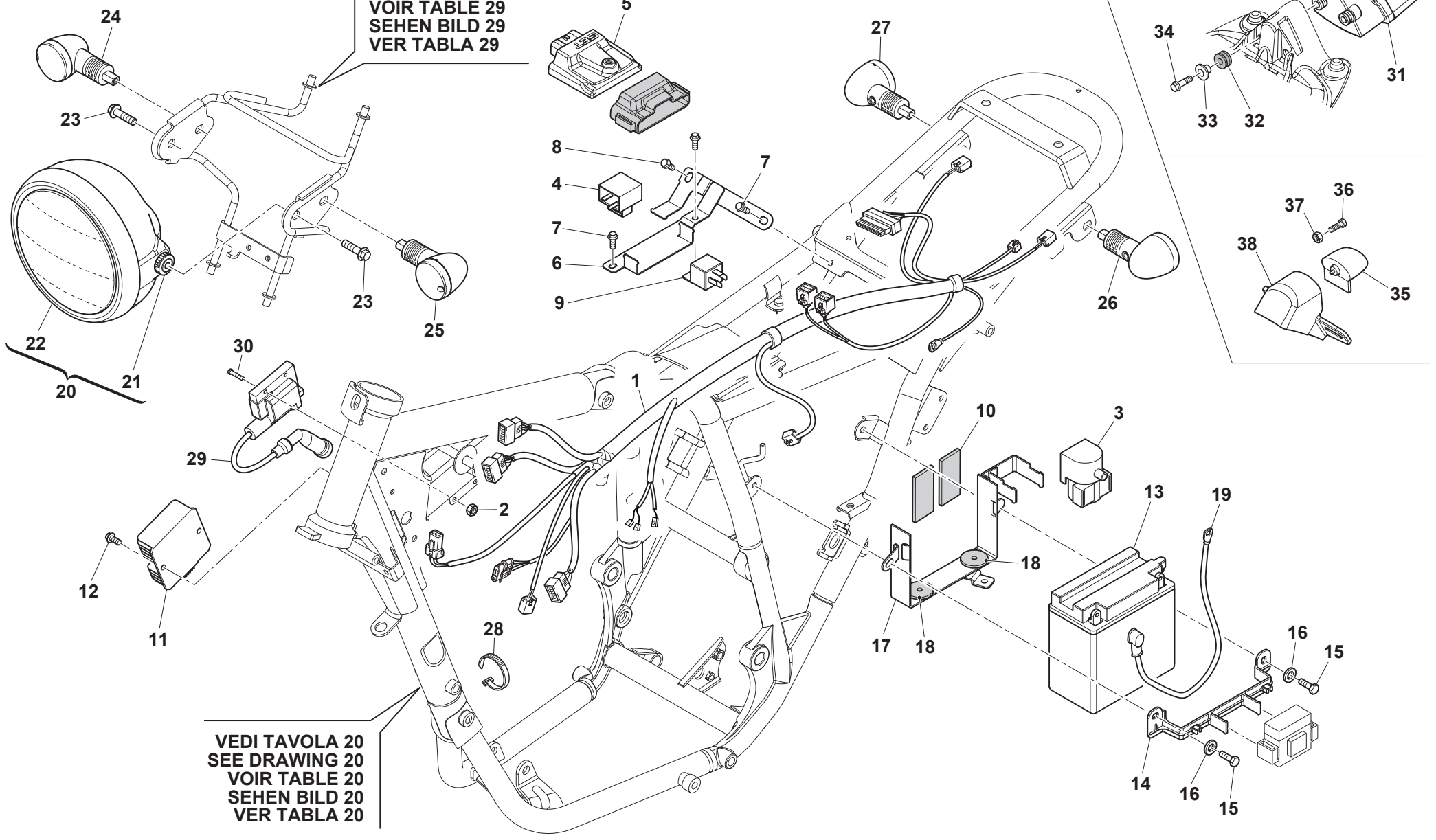

VEDI TAVOLA 20
SEE DRAWING 20
VOIR TABLE 20
SEHEN BILD 20
VER TABLA 20



Note Notes Marke Notas	Pos. No. N. Index Pos.	N. Cod. Code No. Nr. Code Code Nr N. Cod.	Q.tà Q.ty Q.te M.ge C.ad	DENOMINAZIONE	NAME	DESIGNATION	BESHREIBUNG	DENOMINACION
	1	F000E00658	1	CABLAGGIO PRINCIPALE	MAIN CABLE HARNESS	CÂBLAGE PRINCIPAL	HAUPTVERKABELUNG	CABLEADO PRINCIPAL
	2	Z00040717	2	DADO AUTOBLOCCANTE M4	SELF-LOCKING NUT M4	ECROU AUTOBLOQUANT M4	SELBSTSICHERNDE MUTTER M4	TUERCA AUTOBLOCANTE M4
	3	31050077	1	RELE AVVIAMENTO	STARTER RELAY	RELAIS DE DEMARRAGE	STARTER RELAIS	RELÉ DE ARRANQUE
	4	31040019	1	INTERMITTENZA	FLASHER	DISPOSITIF CLIGNOTANTS	BLINKGEBER	INTERMITENCIA
	5	E000P00812	1	CENTRALINA ELETTRONICA	ELECTRONIC CONTROL UNIT	BOÎTIER ÉLECTRONIQUE	STEUERELEKTRONIK	CENTRALITA ELECTRÓNICA
	6	F000P00778	1	STAFFA FISSAGGIO ECU	BRACKET	ETRIER	BÜGEL	ESTRIBO
	7	Z00062726	1	VITE TEF M6x14	FLANGED EXAGON HEAD SCREW M6x14	BOULON DE BRIDE M6x14	FLANSCHENSCHRAUBE M6x14	TORNILLO DE REBORDE M6x14
	8	ZA0067997	1	VITE TEF M5x16	FLANGED EXAGON HEAD SCREW M5x16	BOULON DE BRIDE M5x16	FLANSCHENSCHRAUBE M5x16	TORNILLO DE REBORDE M5x16
	9	31190006	1	RELE POMPA BENZINA	RELAY FUEL PUMP	RELAIS POMPE À CARBURANT	BENZINPUMPE RELAIS	RELÉ BOMBA GASOLINA
	10	73012420	2	SPUGNA ADESIVA	SINGLE-SIDED ADHESIVE	ADHÉSIF EPONGE	KLEBEGUMMI	GOMAESPUMA ADHESIVA
	11	31030087	1	REGOLATORE DI TENSIONE	VOLTAGE REGULATOR	RÉGULATEUR DE TENSION	SPANNUNGSREGLER	REGULADOR DE TENSIÓN
	12	72011991	2	VITE M6x12	SCREW M6x12	VIS M6x12	SCHRAUBE M6x12	TORNILLO M6x12
	13	31070060	1	BATTERIA	BATTERY	BATTERIE	BATTERIE	BATERÍA
	14	73021083	1	STAFFA FISSAGGIO BATTERIA	BRACKET	ETRIER	BÜGEL	ESTRIBO
	15	Z00062726	3	VITE TEF M6x14	FLANGED EXAGON HEAD SCREW M6x14	BOULON DE BRIDE M6x14	FLANSCHENSCHRAUBE M6x14	TORNILLO DE REBORDE M6x14
	16	Z00021535	2	ROSETTA	WASHER	RONDELLE	UNTERLEGSCHIEBE	ARANDELA
	17	73250179	1	SUPPORTO BATTERIA	BATTERY SUPPORT	SUPPORT BATTERIE	BATTERIE HALTERUNG	SOPORTE BATERÍA
	18	73010197	2	GOMMINO APPOGGIO BATTERIA	DAMPING MAT, BATTERY	JOINT EN CAOUTCHOUC	GUMMISCHEIBE	GOMA
	19	31350069	1	CAVO ALTA TENSIONE	HIGH VOLTAGE WIRE	CÂBLE	KABEL	CABLE
	20	F000A00636	1	FANALE ANTERIORE COMPLETO	COMPLETE FRONT HEADLAMP	FEU AVANT COMPLET	FRONTSCHIEBWERFER KOMPLETT	FARO DELANTERO COMPLETO
	21	73012493	2	GOMMINO	RUBBER RING	JOINT EN CAOUTCHOUC	GUMMISCHEIBE	GOMA
	22	F000A00848	1	FANALE ANTERIORE	FRONT HEADLAMP	FEU AVANT	FRONTSCHIEBWERFER	FARO DELANTERO
	23	8A00B1959	2	VITE TEF M8x30	FLANGED EXAGON HEAD SCREW M8x30	BOULON DE BRIDE M8x30	FLANSCHENSCHRAUBE M8x30	TORNILLO DE REBORDE M8x30
	24	32040236	1	INDICATORE ANT. DX	RH FRONT INDICATOR	CLIGNOTANT AV. DROITE	RICHTUNGSANZEIGER VORNE RE	INTERMITENTE DEL. DER.
	25	32050949	1	INDICATORE ANT. SX	LH FRONT INDICATOR	CLIGNOTANT AV. GAUCHE	RICHTUNGSANZEIGER VORNE LI	INTERMITENTE DEL. IZQ.
	26	32030264	1	INDICATORE POST. SX	LH REAR INDICATOR	CLIGNOTANT AR. GAUCHE	RICHTUNGSANZEIGER HINTEN LI	INTERMITENTE TRAS. IZQ.
	27	32020265	1	INDICATORE POST. DX	RH REAR INDICATOR	CLIGNOTANT AR. DROITE	RICHTUNGSANZEIGER HINTEN RE	INTERMITENTE TRAS. DER.
	28	800056444	8	FASCETTA L=188 mm	CLAMP L=188 mm	COLLIER L=188 mm	SHELLE L=188 mm	ABRAZADERA L=188 mm
	29	31020123	1	BOBINA	COIL	BOBINE	ZÜNDSPULE	BOBINA
	30	72030698	2	VITE M4x20	SCREW M4x20	VIS M4x20	SCHRAUBE M4x20	TORNILLO M4x20
	31	F000A00289	1	ASS. FANALE POSTERIORE	COMPLETE TAIL LIGHT	FEU ARRIÈRE COMPLET	HECKSCHIEBWERFER KOMPLETT	PILOTO TRASERO COMPLETO
	32	800041862	2	GOMMINO ANTIVIBRANTE	SILENT-BLOCK	ANTIVIBRATION	SCHWINGUNGSDAMFER	ANTIVIBRADOR
	33	8000B2799	2	DISTANZIALE CON COLLETO	SPACER	ENTRETOISE	ABSTANDHALTER	DISTANCIADOR

VEDI TAVOLA 29
SEE DRAWING 29
VOIR TABLE 29
SEHEN BILD 29
VER TABLA 29

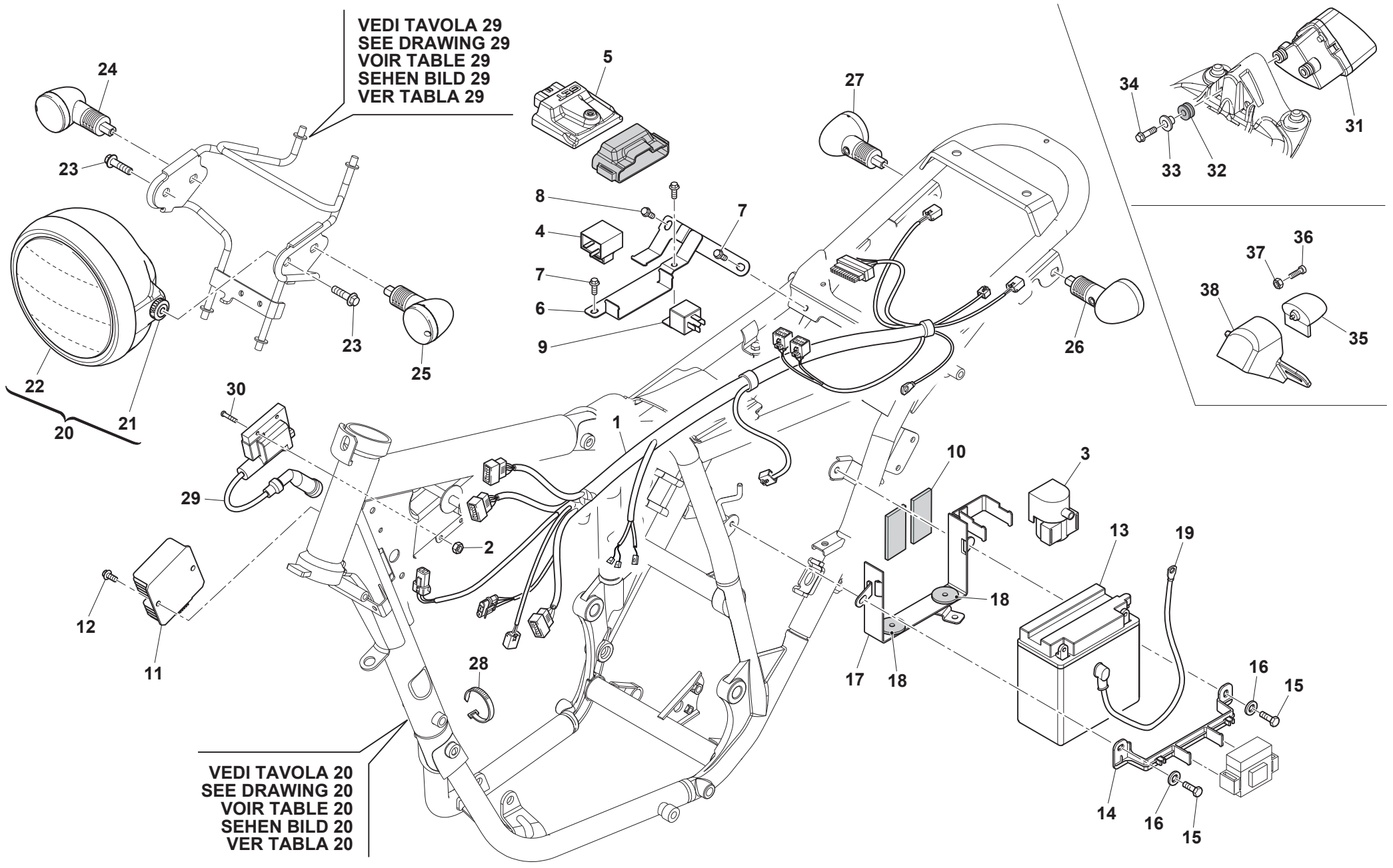

VEDI TAVOLA 20
SEE DRAWING 20
VOIR TABLE 20
SEHEN BILD 20
VER TABLA 20



Note Notes Marke Notas	Pos. No. Index Pos.	N. Cod. Code No. Nr. Code Code Nr N. Cod.	Q.tà Q.ty Q.te M.ge C.ad	DENOMINAZIONE	NAME	DESIGNATION	BESHREIBUNG	DENOMINACION
	34	Z00062726	2	VITE TEF M6x14	FLANGED EXAGON HEAD SCREW M6x14	BOULON DE BRIDE M6x14	FLANSCHENSCHRAUBE M6x14	TORNILLO DE REBORDE M6x14
	35	E000A00871	1	LUCE TARGA	LICENCE PLATE LIGHT	FEU DE PLAQUE	KENNZEICHENBELEUCHTUNG	LUZ MATRÍCULA
	36	60ND07330	1	VITE TCEI M5x16	SCREW TCEI M5x16	VIS TCEI M5x16	SCHRAUBE TCEI M5x16	TORNILLO TCEI M5x16
	37	61ND15192	1	DADO FRENATO	SELF-LOCKING NUT	ECROU AUTOBLOQUANT	SELBSTSICHERNDE MUTTER	TUERCA AUTOBLOCANTE
	38	F000P00309	1	SUPPORTO	SUPPORT	SUPPORT	HALTERUNG	SOPORTE

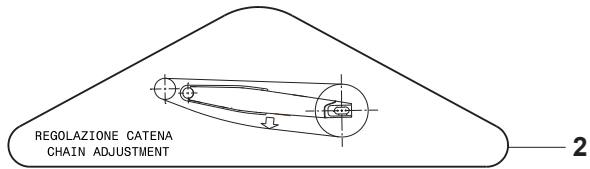

1

IMPORTANT INFORMATION			
Cold Tyre Inflation Pressure			
DRIVER ONLY	FRONT	1.8 bar.	26.1 psi
	REAR	2.0 bar.	29.0 psi
DRIVER AND PASSENGER	FRONT	2.0 bar.	29.0 psi
	REAR	2.2 bar.	31.9 psi

