

# Superdual 2017

Ed. 05-2017 - Rev. 00



**Catalogo ricambi**  
**Spare parts catalog**  
**Catalogue pieces de rechange**  
**Ersatzteilkatalog**  
**Catalogo piezas de repuestos**



## INFORMAZIONI GENERALI

Il presente catalogo serve per richiedere con esattezza le parti di ricambio  
Nelle ordinazioni indicare:

- 1) il numero di codice dei particolari seguito dalla descrizione;
- 2) il colore per i pezzi verniciati o comunque colorati;
- 3) il numero di matricola del motociclo, stampigliato sul canotto di sterzo.

Le indicazioni destra e sinistra si riferiscono ai lati del veicolo rispetto al senso di marcia;

Dati indicativi soggetti a modifiche senza impegno di preavviso.

All data are subject to modification without prior notice.

Données indicatif sujet au modifications sans obligation de préavis.

Anderungen Vorbehalten.

Datos indicativos sujetos a modificaciones sin compromiso de preaviso.

## GENERAL INFORMATION

The present spare parts list enables one to order exactly the right spare parts.

When ordering specify:

- 1) the part's code number followed by its description;
- 2) indicate colour for painted or coloured parts;
- 3) the motorcycle's serial number, stamped on the steering head.

References to right and left apply to the vehicle in terms of its direction of movement.

## NOTE - LIST - NOTES - NOTE - NOTAS:

AUS : Australia, Australia, Australie, Australien, Australia

CDN : Canada, Canada, Canada, Kanada, Canadá

IT : Italia, Italy, Italie, Italien, Italia

JAP : Giappone, Japan, Japon, Japan, Japón

USA : Stati Uniti d'America, United States of America, Etats Units d'Amerique, Vereinigte Staaten von Amerika, Estados Unidos

N° DI MATRICOLA INIZIALE - INITIAL SERIAL NUMBER - MATRICULE  
INITIAL - BEGINNTESEIENNUMMER - MATRICULA INICIAL

MODELLO - MODEL  
MODELE - MODELL  
MODELO

MATRICOLA - SERIAL NUMBER  
MATRICULE - SERIENNUMMER  
MATRICULA

Superdual 2017

ZN0A100AABV000001

## INFORMATIONS GENERALES

Ca catalogue permet de commander correctement les pièces de rechange.

Les commandes doivent être passées en indiquant:

- 1) le numéro de code des pièces détachées suivi de leur description;
- 2) le couleur des pièces peintes ou colorés;
- 3) le matricule de la moto, estampillé sur la tige du guidon.

Droite et gauche sont les côtés du véhicule par rapport au sens de la marche.

## ALLGEMEINE HINWEISE

Dieser Ersatzteilkatalog dient zur genauen Angabe der Teile bei Ersatzteilbestellungen.

Bei Ersatzbestellung ist folgendes anzugeben:

- 1) Die Bestellnummer der Ersatzteile mit der entsprechenden Beschreibung;
- 2) Farbe für lackierte und farbige Teile angeben;
- 3) Die Sseriennummer des Motorrads, die am Lenkrohr eingepägt ist.

Die Angaben rechts und links beziehen sich auf das Fahrzeug in Fahrriichtung.

## INFORMACIONES GENERALES

El presente catálogo sirve para pedir con exactitud las partes de recambio.

En los pedidos se debe indicar:

- 1) el número de código de la parte y a continuación la descripción;
- 2) el color para las piezas barnizadas o coloreadas;
- 3) el número de matrícula de la motocicleta, estampado en le tubo de dirección.

Las indicaciones derecha e izquierda se refieren a los lados del vehículo respecto del sentido de marcha.



# INDICE – INDEX – INDEX – INHALTSVERZEICHNIS - INDICE

**Superdual 2017**

Tavola Drawing Table Bild Tabla	Denominazione	Description	Designation	Bezeichnung	Denominacion	Pagina Page Page Seite Paja
1	ATTREZZI DI ASSISTENZA, MANUALI E CATALOGHI	SERVICE TOOLS, MANUALS AND CATALOGS	OUTILS D'ASSISTANCE, MANUELS ET CATALOGUES	HILFAUSRUSTUNG, HANDBUCH UND KATALOG	HERRAMIENTAS DE ASISTENCIA, MANUALES Y CATALOGOS	13
2	CILINDRO, PISTONE	CYLINDER, PISTON	CYLINDRE, PISTON	ZYLINDER, KOLBEN	CILINDRO, PISTON	15
3	TESTA CILINDRO	CYLINDER HEAD	CULASSE	ZYLINDERKOPF	CULATA	17
4	MANOVELLISMO	CRANKSHAFT	VILEBREQUIN	KURBELWELLE	CIGÜEÑAL	23
5	TRASMISSIONE PRIMARIA, FRIZIONE	PRIMARY DRIVE, CLUTCH	TRANSMISSION PRIMAIRE, EMBRAYAGE	PRIMÄRÜBERSETZUNG, KUPPLUNG	TRANSMISION PRIMARIA, EMBRAGUE	25
6	DISTRIBUZIONE	VALVE TIMING	DISTRIBUTION	VENTILSTEUERUNG	DISTRIBUCION	29
7	SEMICARTER SINISTRO	L.H. HALF CRANKCASE	CARTER G.	GEHAUSEDECKEL L.	BANCADA IZQ.	31
8	SEMICARTER DESTRO	R.H. HALF CRANKCASE	CARTER D.	GEHAUSEDECKEL R.	BANCADA DER.	33
9	COPERCHI BASAMENTO	CRANKCASE COVERS	COUVERCLES CARTER	GEHAUSEDECKEL	TAPAS BANCADA	35
10	COMANDO CAMBIO	GEARSHIFT MECHANISM	COMMANDE DE VITESSE	GANGSCHALTUNG	MANDO CAMBIO	37
11	LUBRIFICAZIONE	OIL PUMP	PUMPE HUILE	MOTORSCHMIERUNG	LUBRICACION	39
12	PARTE ELETTRICA, IMPIANTO ELETTRICO	IGNITION SYSTEM, ELECTRIC SYSTEM	PARTIES ELECTRIQUE, INSTALLATION ELECTRIQUE	ELEKTRISCHE TEILE, ELEKTRISCHE ANLAGE	PARTE ELECTRICA, INSTALLACION ELECTRICA	43
13	CORPO FARFALLATO	THROTTLE BODY	CORP PAPILLON	DROSSELKLAPPENKÖRPER	CUERPO OSCILANTE	45
14	FILTRO ARIA	AIR FILTER	FILTRE AIRE	LUFTFILTER	FILTRO DE AIRE	47
15	IMPIANTO DI RAFFREDAMENTO	COOLING SYSTEM	INSTALLATION RAFROIDISSEMENT	SCHMIERUNGSSYSTEM	EQUIPO DE ENFRIAMIENTO	49
16	TELAIO, PEDANE	FRAME, FOOT RESTS	CADRE, REPOSE PIEDS	RAHMEN, FUSSBRETT	BASTIDOR, REPOSAPIES	53
17	SOSPENSIONE ANTERIORE	FRONT FORK ASSEMBLY	SUSPENSION AVANT	VORDETELESKOPGABEL	SUSPENSION DELANTERA	57
18	FORCELLONE POSTERIORE	REAR SWING ARM	FOURCHE ARRIERE	HINTERGABEL	HORQUILLA TRASERA	59
19	LEVRAGGI SOSPENSIONE POSTERIORE	REAR SUSPENSION LINKAGE	LEVIER SUSPENSION ARRIERE	HEBELWERK HINTERHAUFHANGUNG	PALANCA SUSPENSION TRASERA	63
20	AMMORTIZZATORE POSTERIORE	REAR SUSPENSION	SUSPENSION ARRIERE	HINTERHAUFHANGUNG	SUSPENSION TRASERA	65
21	MANUBRIO E COMANDI	HANDLEBAR AND CONTROLS	GUIDON ET COMMANDES	LENKER UND STEUERORGANE	MANILLAR Y MANDOS	67
22	PANNELLI, PARAFANGHI, SELLA	PANEL, FENDERS, SEAT,	PANNEAU, GARDE-BOUES, SIEGE,	STREIFEN, KOTFLUGEL, SATTEL	PANELO, GUARDABARROS, SILLIN	69
23	SERBATOIO CARBURANTE, CONVOGLIATORI	GAS TANK, PANEL	RESERVOIR CARBURANT, FLANC	KRAFTSTOFFBEHALTER, FLANKE	DEPOSITO GASOLINA, LATERAL	73
24	SCARICO	EXHAUST SYSTEM	TUYAU D'ECHAPPEMENT	AUSPUFFROHR	TUBO DE ESCAPE	77
25	FRENO IDRAULICO ANTERIORE	FRONT HYDRAULIC BRAKE	FREIN HYDRAULIQUE AVANT	VORDERBREMSE	FRENO HIDRAULICO DELANTERO	79
26	FRENO IDRAULICO POSTERIORE	REAR HYDRAULIC BRAKE	FREIN HYDRAULIQUE ARRIERE	HINTERBREMSE	FRENO HIDRAULICO TRASERO	81
27	RUOTA ANTERIORE	FRONT WHEEL	ROUE AVANT	VORTERRAD	RUEDA DELANTERA	83
28	RUOTA POSTERIORE	REAR WHEEL	ROUE ARRIERE	HINTERRAD	RUEDA TRASERA	85
29	STRUMENTO DIGITALE	DIGITAL INSTRUMENT,	INSTRUMENT DIGITAL	DIGITAL TACHOMETER	INSTRUMENTO DIGITAL	87





Tavola - Drawing - Table - Bild - Tabla

1

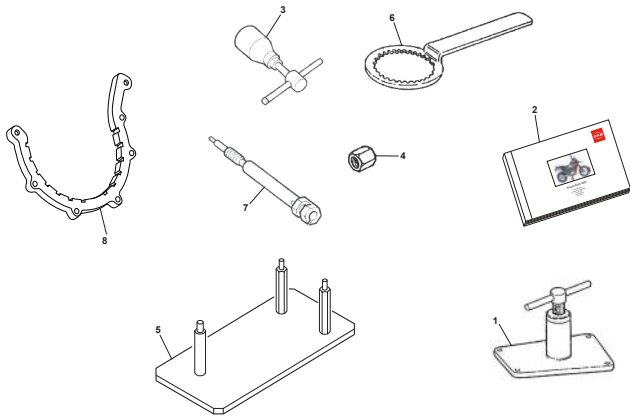

Pagina - Page - Page - Seite - Paja

12

Tavola - Drawing - Table - Bild - Tabla

2

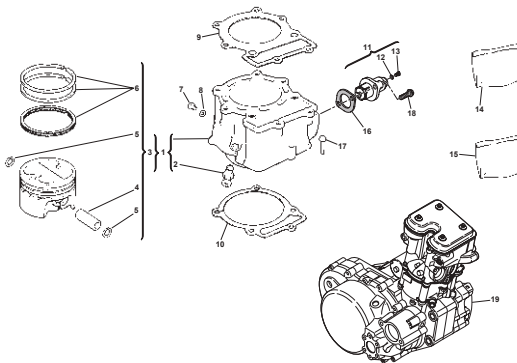

Pagina - Page - Page - Seite - Paja

14

Tavola - Drawing - Table - Bild - Tabla

3

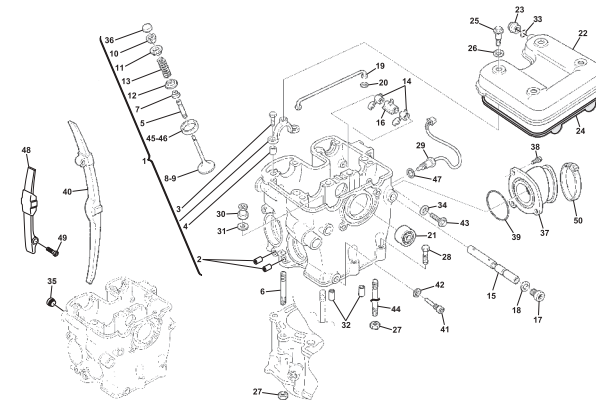

Pagina - Page - Page - Seite - Paja

16

Tavola - Drawing - Table - Bild - Tabla

4

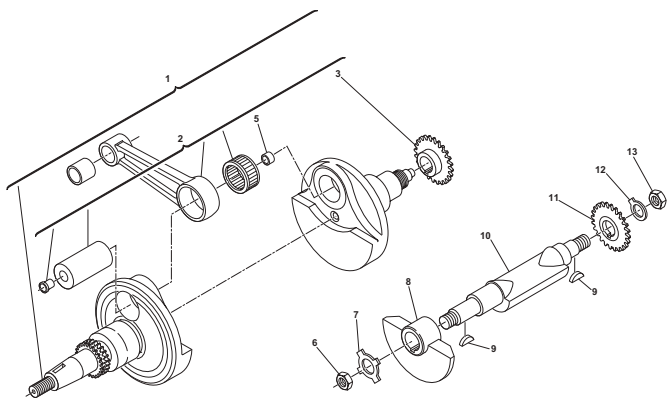

Pagina - Page - Page - Seite - Paja

22

Tavola - Drawing - Table - Bild - Tabla

5

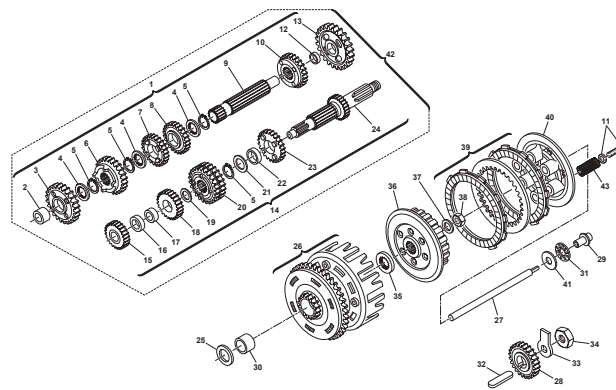

Pagina - Page - Page - Seite - Paja

24

Tavola - Drawing - Table - Bild - Tabla

6

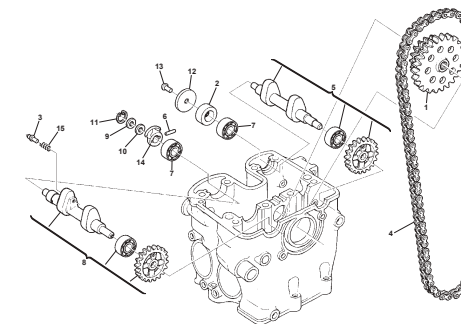

Pagina - Page - Page - Seite - Paja

28

Tavola - Drawing - Table - Bild - Tabla

7

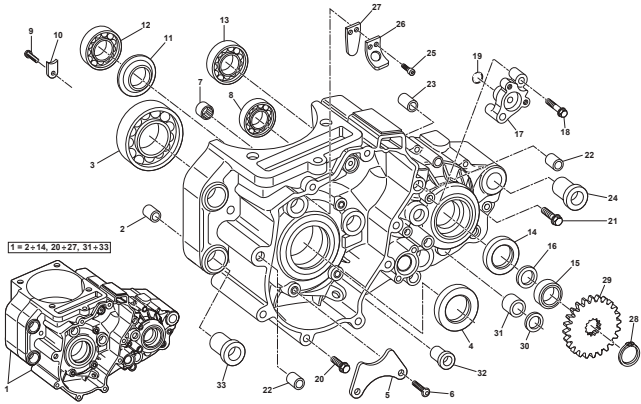

Pagina - Page - Page - Seite - Paja

30

Tavola - Drawing - Table - Bild - Tabla

8

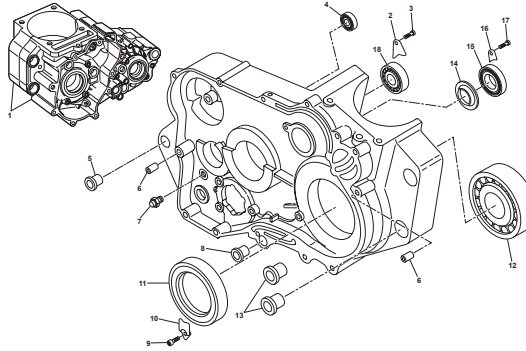

Pagina - Page - Page - Seite - Paja

32

Tavola - Drawing - Table - Bild - Tabla

9

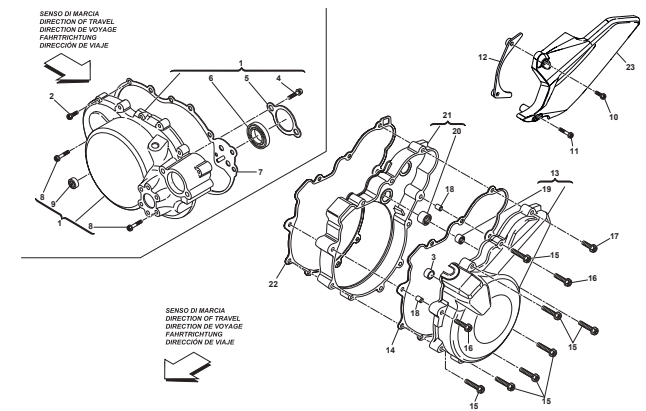

Pagina - Page - Page - Seite - Paja

34

Tavola - Drawing - Table - Bild - Tabla

10

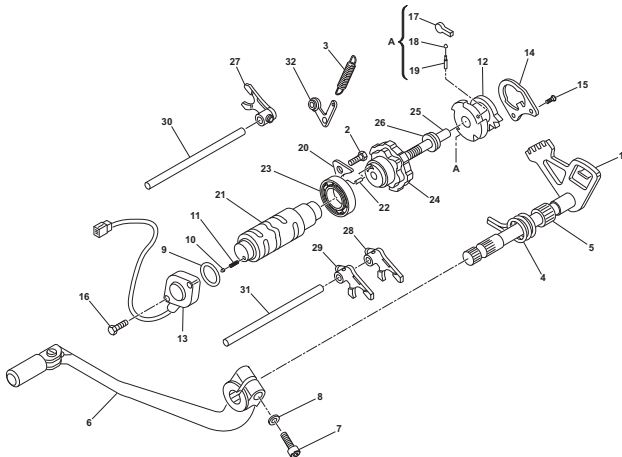

Pagina - Page - Page - Seite - Paja

36

Tavola - Drawing - Table - Bild - Tabla

11

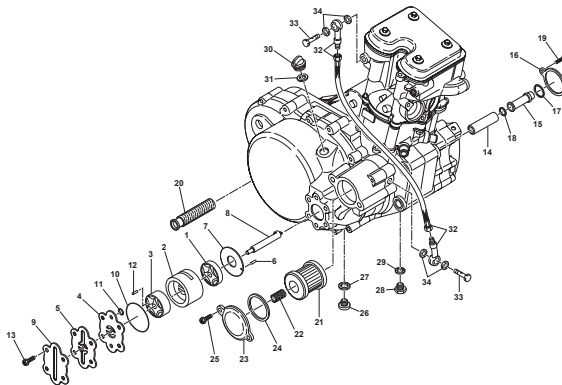

Pagina - Page - Page - Seite - Paja

38

Tavola - Drawing - Table - Bild - Tabla

12

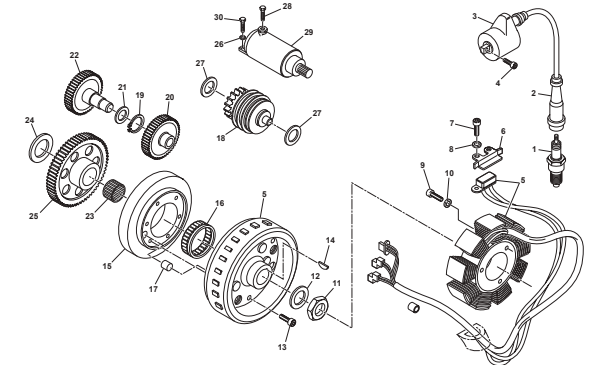

Pagina - Page - Page - Seite - Paja

42

Tavola - Drawing - Table - Bild - Tabla

13

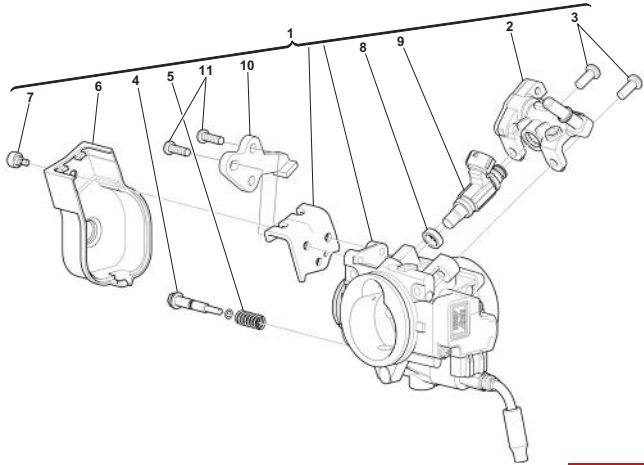

Pagina - Page - Page - Seite - Paja

44

Tavola - Drawing - Table - Bild - Tabla

14

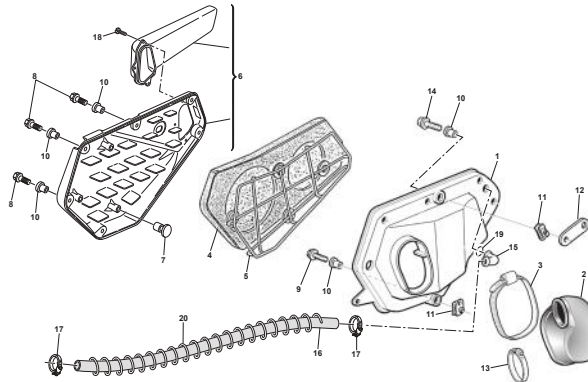

Pagina - Page - Page - Seite - Paja

46

Tavola - Drawing - Table - Bild - Tabla

15

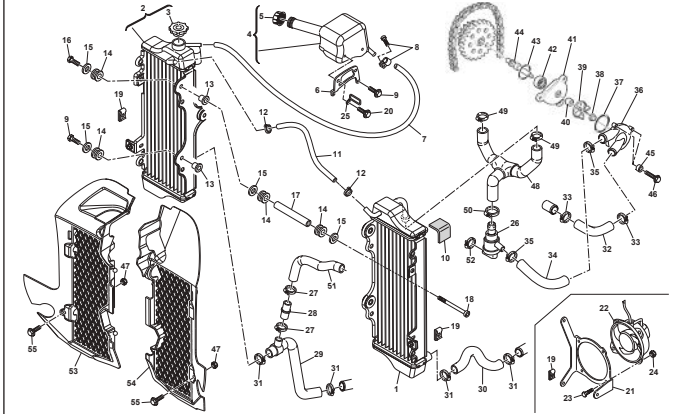

Pagina - Page - Page - Seite - Paja

48

Tavola - Drawing - Table - Bild - Tabla

16A

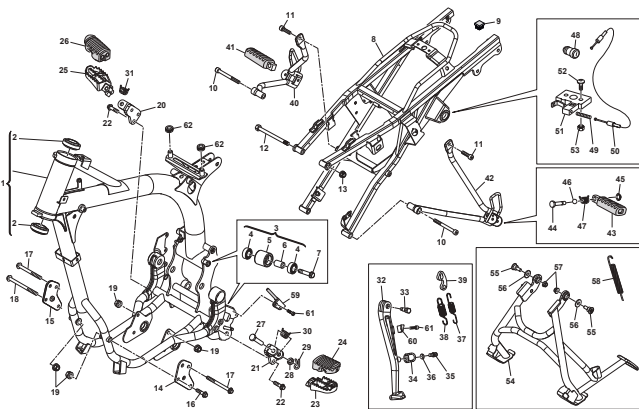

Pagina - Page - Page - Seite - Paja

52

Tavola - Drawing - Table - Bild - Tabla

16B

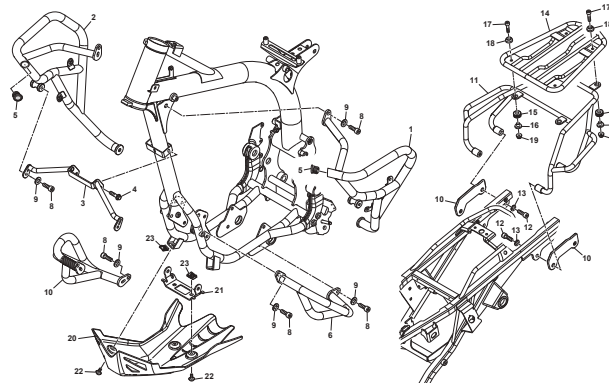

Pagina - Page - Page - Seite - Paja

56

Tavola - Drawing - Table - Bild - Tabla

17

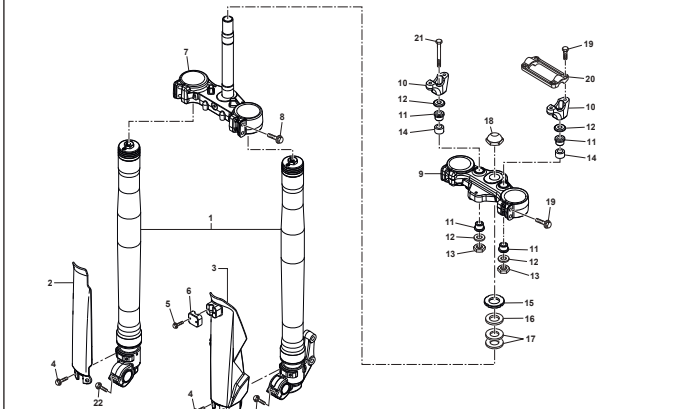

Pagina - Page - Page - Seite - Paja

58

Tavola - Drawing - Table - Bild - Tabla

18

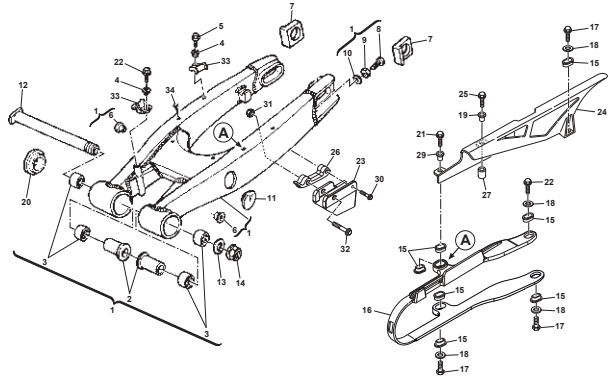

Pagina - Page - Page - Seite - Paja

60

Tavola - Drawing - Table - Bild - Tabla

19

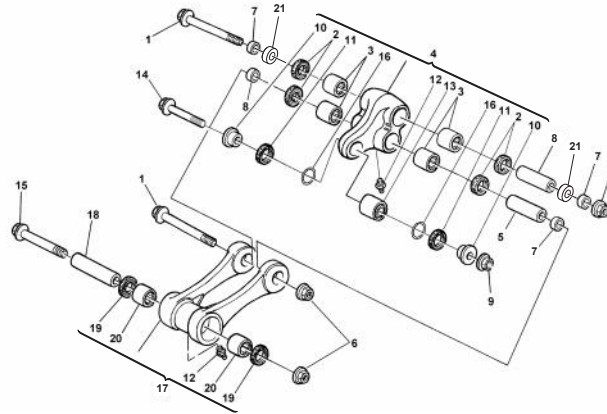

Pagina - Page - Page - Seite - Paja

64

Tavola - Drawing - Table - Bild - Tabla

20

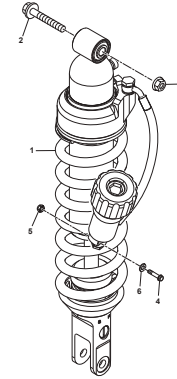

Pagina - Page - Page - Seite - Paja

66

Tavola - Drawing - Table - Bild - Tabla

21

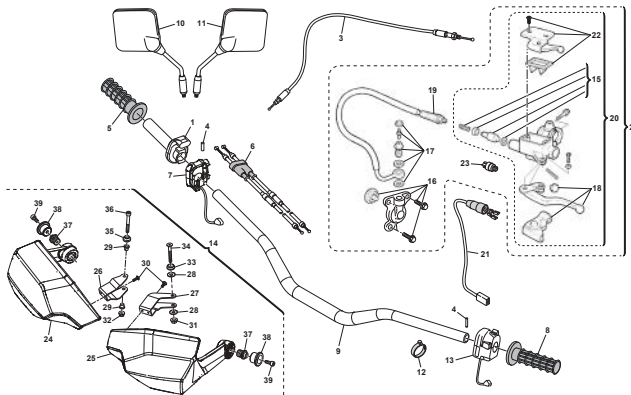

Pagina - Page - Page - Seite - Paja

68

Tavola - Drawing - Table - Bild - Tabla

22

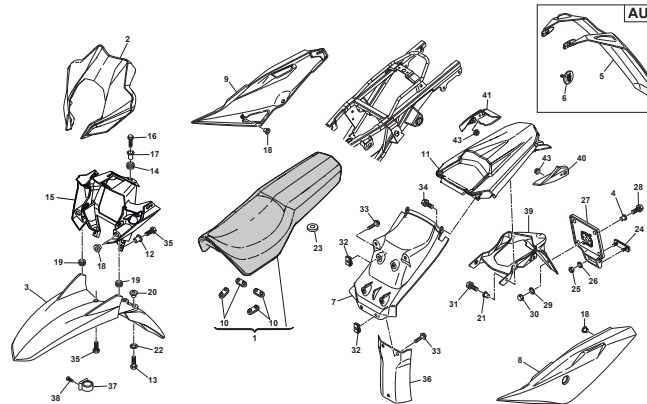

Pagina - Page - Page - Seite - Paja

72

Tavola - Drawing - Table - Bild - Tabla

23

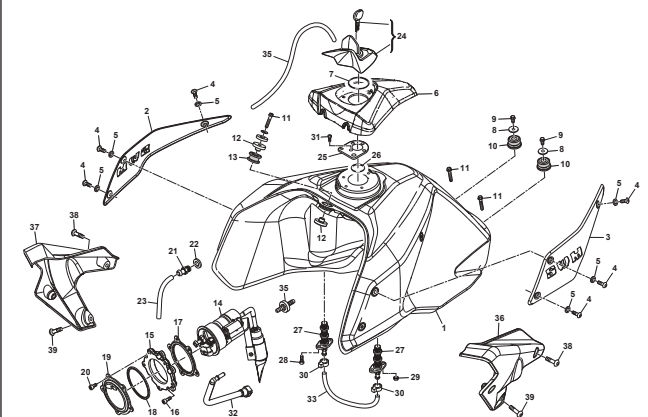

Pagina - Page - Page - Seite - Paja

76





Tavola - Drawing - Table - Bild - Tabla

24

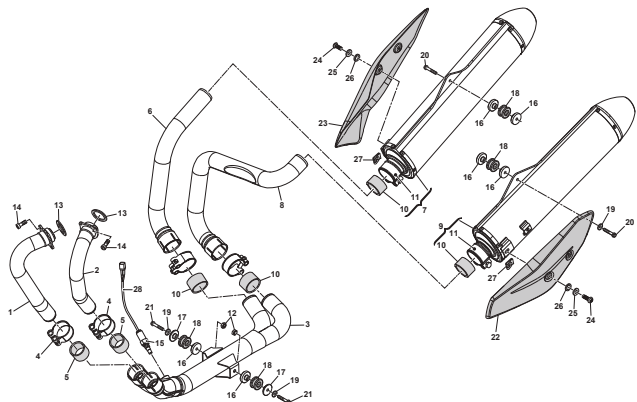

Pagina - Page - Page - Seite - Paja

80

Tavola - Drawing - Table - Bild - Tabla

25

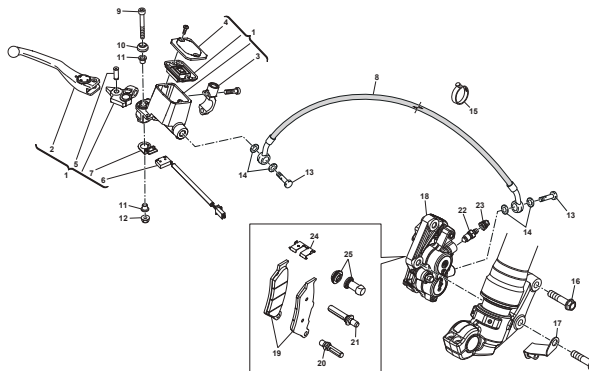

Pagina - Page - Page - Seite - Paja

82

Tavola - Drawing - Table - Bild - Tabla

26

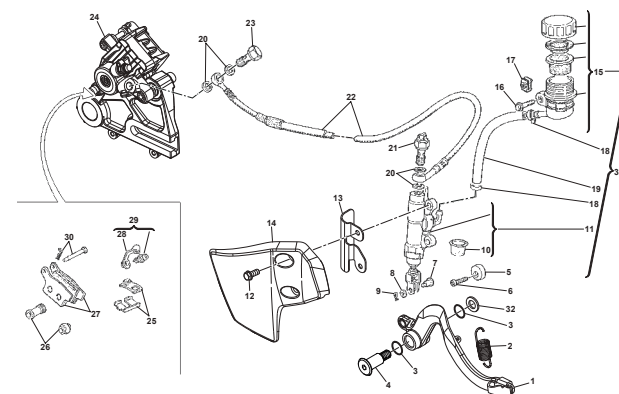

Pagina - Page - Page - Seite - Paja

84

Tavola - Drawing - Table - Bild - Tabla

27

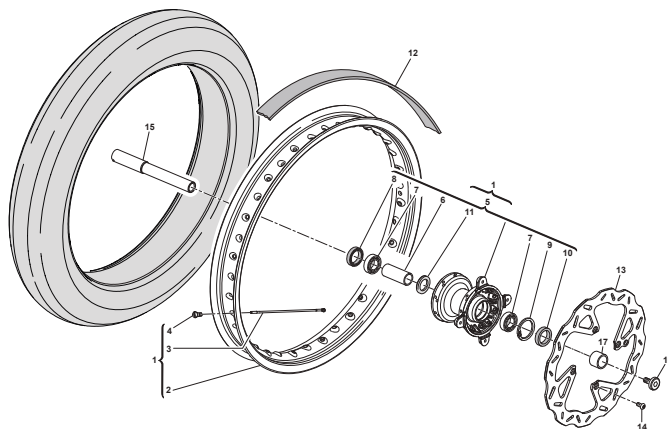

Pagina - Page - Page - Seite - Paja

86

Tavola - Drawing - Table - Bild - Tabla

28

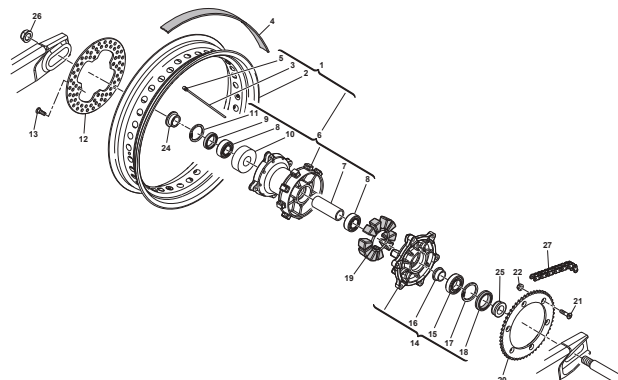

Pagina - Page - Page - Seite - Paja

88

Tavola - Drawing - Table - Bild - Tabla

29

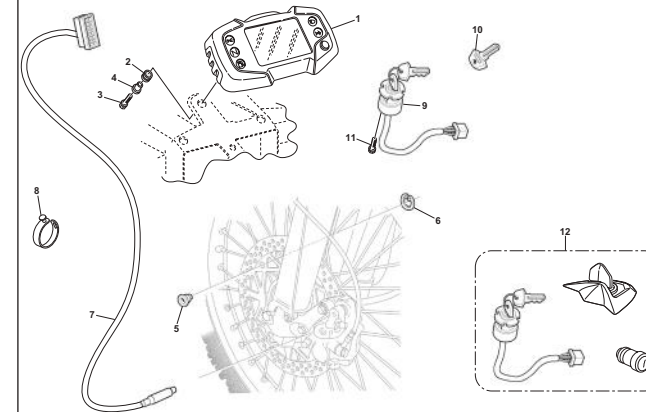

Pagina - Page - Page - Seite - Paja

90

Tavola - Drawing - Table - Bild - Tabla

30

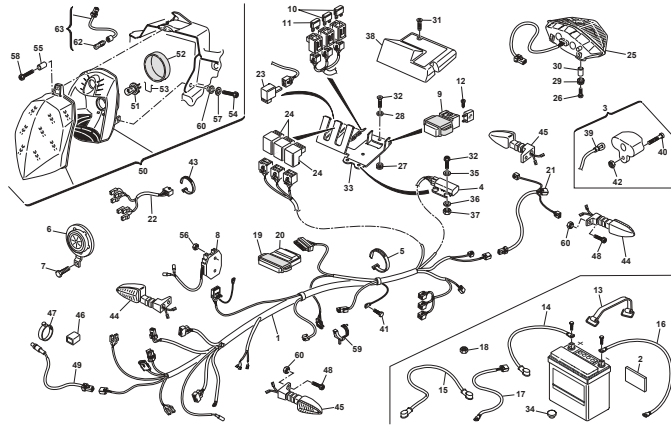

Pagina - Page - Page - Seite - Paja

92

Tavola - Drawing - Table - Bild - Tabla

31

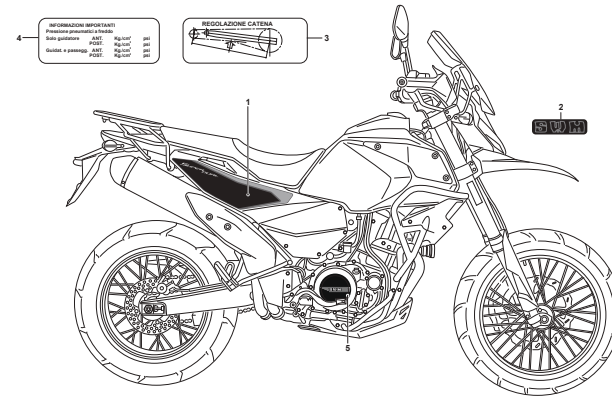

Pagina - Page - Page - Seite - Paja

96



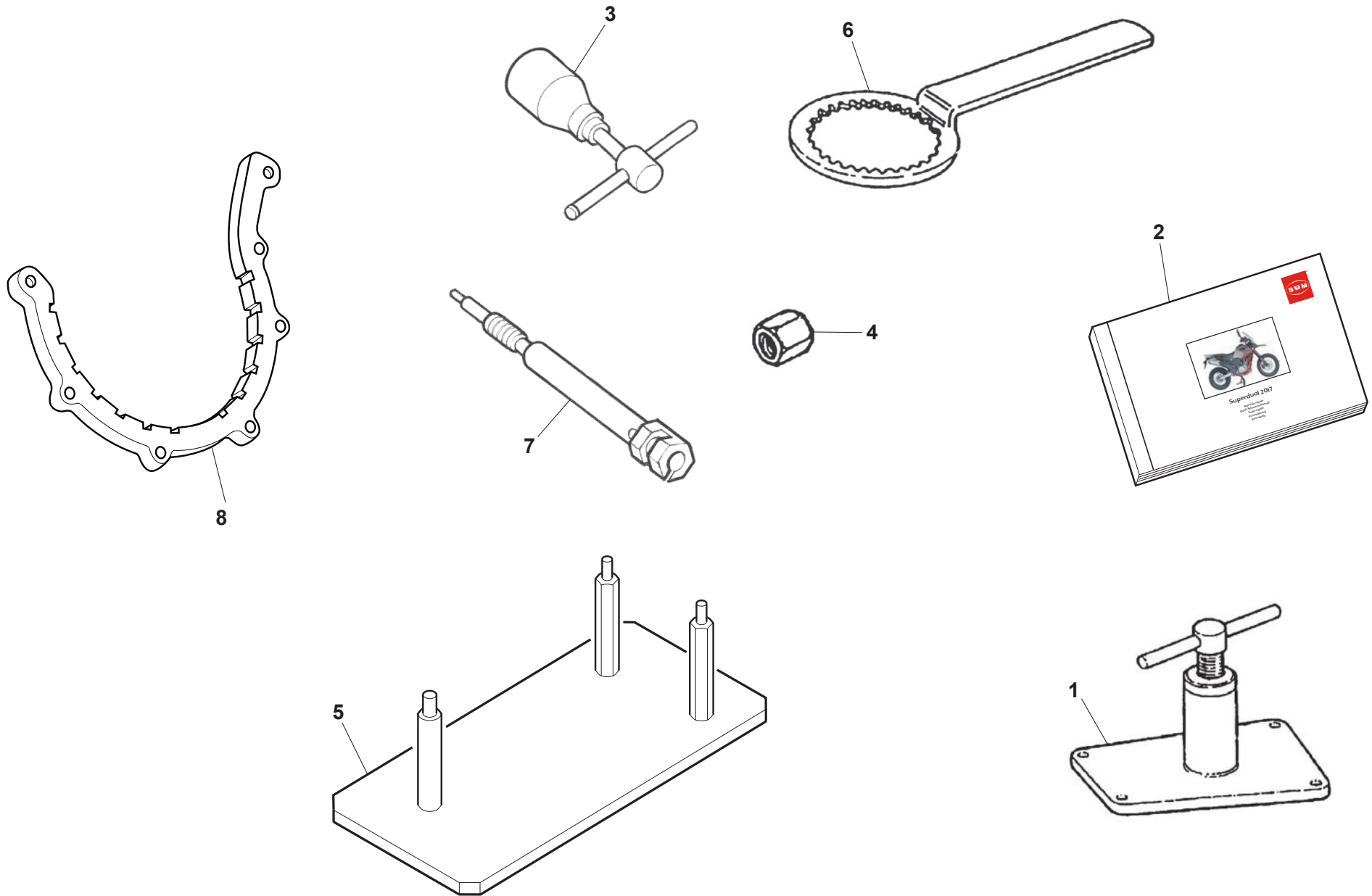



**Superdual 2017**

**ATTREZZI DI ASSISTENZA,MANUALI E CATALOGHI - SERVICE TOOLS, MANUALS AND CATALOGS  
OUTILS D'ASSISTANCE, MANUELS ET CATALOGUES - HILFAUSRUSTUNG, HANDBUCH UND KATALOG  
HERRAMIENTAS DE ASISTENCIA, MANUALES Y CATALOGOS**

TAVOLA  
DRAWING  
TABLE  
BILD  
TABLA

1

Note Notes Marke Notas	Pos. No. Index Pos.	N. Cod. Code No. Nr. Code Code Nr N. Cod.	Q.tà Q.ty Q.te M.ge C.ad	DENOMINAZIONE	NAME	DESIGNATION	BESHREIBUNG	DENOMINACION
	1	800089743	1	ESTRATTORE CARTER MOTORE	PULLER, CRANKCASE	EXTRACTEUR CARTER MOTEUR	AUSZIEHER, KURBELGEHAUSE	EXTRACTOR CARTER MOTOR
	2	A000P02252	1	MANUALE RAPIDO	QUICK MANUAL	GUIDE RAPIDE	KURZANLEITUNG	GUIA RAPIDA
	3	800039523	1	ESTRATTORE VOLANO	FLYWHEEL PULLER	EXTRACTEUR VOLANT MAGNETIQUE	AUSZIEHER, SCHWUNGRAD	EXTRACTOR VOLANTE
	4	800083254	1	PROTEZIONE ALBERO MOTORE ESTRAZ. VOLANO	TOOL GUARD CRANKSHAFT	OUTIL PROTECTION VILEBREQUIN	WERKZEUG KURBELWELLESCHUTZ	PROTECCION CIGUENAL
	5	800090662	1	SUPPORTO MONTAGGIO MOTORE	BENCH ENGINE REPAIR	BANC TRAVAIL REPARATION MOTEUR	WERKBANK MOTORREPARATUR	BANCADA TRABAJO REPARACION MOTOR
	6	800079015	1	CHIAVE BLOCCAGGIO FRIZIONE	TOOL, RETAINING CLUTCH HUB	OUTIL VERROULAGE MOYEAU EMBRAYAGE	BLOCKIERUNGSWERKZEUG DER KUPPLUNGSNABE	HERRAMIENTA BLOQUEANTE CUBO EMBRAGUE
	7	8000A1625	1	ATTREZZO PORTACOMPARATORE	DIAL GAUGE HOLDING TOOL	OUTIL SUPPORT COMPARATEUR	WERKZEUG MESSUHRHALTER	HERRAMIENTA PORTA RELOJ COMPARADOR
	8	M000P00688	1	ATTREZZO FERMO PMS	PMS TOOL	OUTIL PMS	GERÄT PMS	HERRAMIENTA PMS

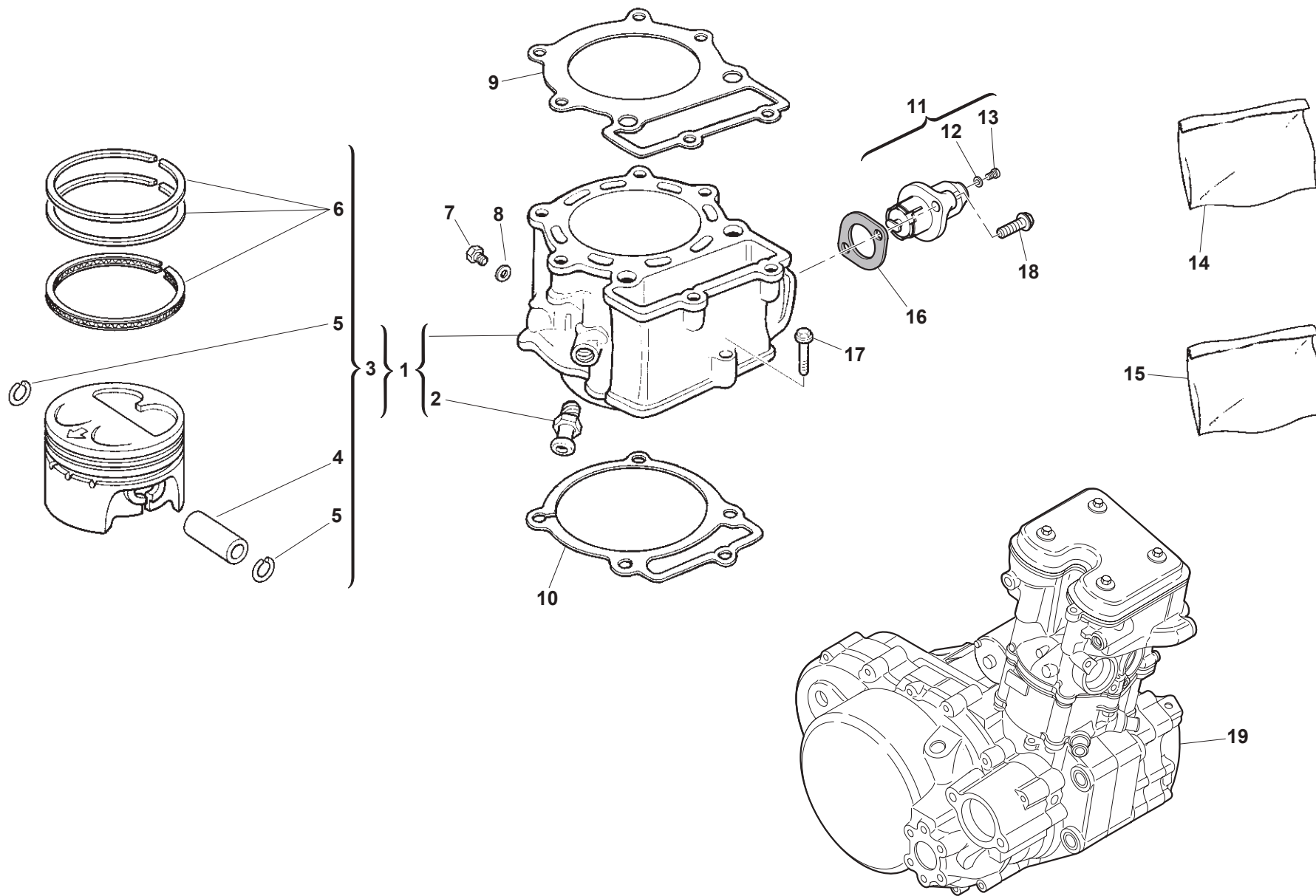



Superdual 2017

CILINDRO, PISTONE - CYLINDER, PISTON  
CYLINDRE, PISTON- ZYLINDER, KOLBEN  
CILINDRO, PISTON

TAVOLA  
DRAWING  
TABLE  
BILD  
TABLA

2

Note Notes Notes Marke Notas	Pos. No. Index Pos.	N. Cod. Code No. Nr. Code Code Nr N. Cod.	Q.tà Q.ty Q.te M.ge C.ad	DENOMINAZIONE	NAME	DESIGNATION	BESHREIBUNG	DENOMINACION
	1	M000A00100	1	CILINDRO COMPLETO	CYLINDER ASSY	CYLINDRE COMPLET	ZYLINDER KOMPL	CILINDRO COMPLETO
	2	800063885	2	RACCORDO	JOINT	RACCORD	ANSCHLUSS	EMPALME
	3	8000H6251	1	PISTONE COMPLETO	PISTON ASSY	PISTON COMPLET	KOLBEN KOMPLETT	PISTON COMPLETO
	4	8000A9652	1	SPINOTTO PISTONE	PIN, PISTON	AXE PISTON	KOLBENBOLZEN	BULON PISTON
	5	8000A5475	2	ANELLINO FERMA SPINOTTO	CLIP PISTON PIN	ATTACHE AXE PISTON	SICHERUNG, KOLBENBOLZEN	GRAPA, BULON PISTON
	6	8000H6252	1	SERIE SEGMENTI	PISTON RING SET	JEU SEGMENT PISTON	KOLBENRING SATZ	JUEGO ARO PISTON
	7	ZS0067545	1	VITE TEF M6X1X8 CH8	SCREW TEF M6X1X8 CH8	VIS TEF M6X1X8 CH8	SCHRAUBE TEF M6X1X8 CH8	TORNILLO TEF M6X1X8 CH8
	8	8A0015960	1	GUARNIZIONE 10X6,2X1	GASKET 10X6,2X1	JOINT 10X6,2X1	DICHTUNG 10X6,2X1	JUNTA 10X6,2X1
	9	8A00H0937	1	GUARNIZIONE TESTA CILINDRO 1,1 mm	GASKET CYLINDER HEAD 1.1 mm	JOINT CULASSE 1,1 mm	DICHTUNG ZYLINDERKOPF 1,1 mm	JUNTA CULATA 1,1 mm
	9	8B00H0937	1	GUARNIZIONE TESTA CILINDRO 1,0 mm	GASKET CYLINDER HEAD 1.0 mm	JOINT CULASSE 1,0 mm	DICHTUNG ZYLINDERKOPF 1,0 mm	JUNTA CULATA 1,0 mm
	9	8000H0937	1	GUARNIZIONE TESTA CILINDRO 1,2 mm	GASKET CYLINDER HEAD 1.2 mm	JOINT CULASSE 1,2 mm	DICHTUNG ZYLINDERKOPF 1,2 mm	JUNTA CULATA 1,2 mm
	10	800099841	1	GUARNIZIONE BASE CILINDRO	GASKET, CYLINDER BASE	JOINT BASE CYLINDRE	DICHTUNG, ZYLINDER	JUNTA BASE CILINDRO
	11	8000A6950	1	TENDICATENA DISTRIBUZIONE	TENSIONER, TIMING CHAIN	TENDEUR CHAINE DISTRIBUTION	STEUERKETTENSANNER	TENSIONADOR CADENA DISTRIBUCION
	12	8000A6358	1	RONDELLA	WASHER	RONDELLE	SCHEIBE	ARANDELA
	13	8000A6357	1	VITE TEF M6X8	SCREW TEF M6X8	VIS TEF M6X8	SCHRAUBE TEF M6X8	TORNILLO TEF M6X8
	14	M000A01129	1	SERIE GUARNIZIONI MOTORE	GASKET SET, ENGINE	JEU JOINT MOTEUR	MOTORDICHTUNGSSATZ	JUEGO JUNTAS MOTOR
	15	8000H1761	1	SERIE PARAOLIO MOTORE	OIL SEAL SET, ENGINE	JEU BAGUES ETANCHEITE MOTEUR	MOTORWELLENDICHTRINGENSATZ	JUEGO RETENES ACEITE MOTOR
	16	8000A6954	1	GUARNIZIONE TENDICATENA DISTRIBUZIONE	GASKET, TENSIONER ADJUSTER	JOINT TENDEUR CHAINE DISTRIBUTION	DICHTUNG STEUERKETTENSANNER	JUNTA TENSIONADOR CADENA DISTRIBUCION
	17	Z00062730	2	VITE TE M6X1X30 CH8	SCREW TE M6X1X30 CH8	VIS TE M6X1X30 CH8	SCHRAUBE TE M6X1X30 CH8	TORNILLO TE M6X1X30 CH8
	18	Z00062728	2	VITE TEF M6X1X20 CH8	SCREW TEF M6X1X20 CH8	VIS TEF M6X1X20 CH8	SCHRAUBE TEF M6X1X20 CH8	TORNILLO TEF M6X1X20 CH8
	19	M000A00030	1	MOTORE	ENGINE	MOTEUR	MOTOR	MOTOR

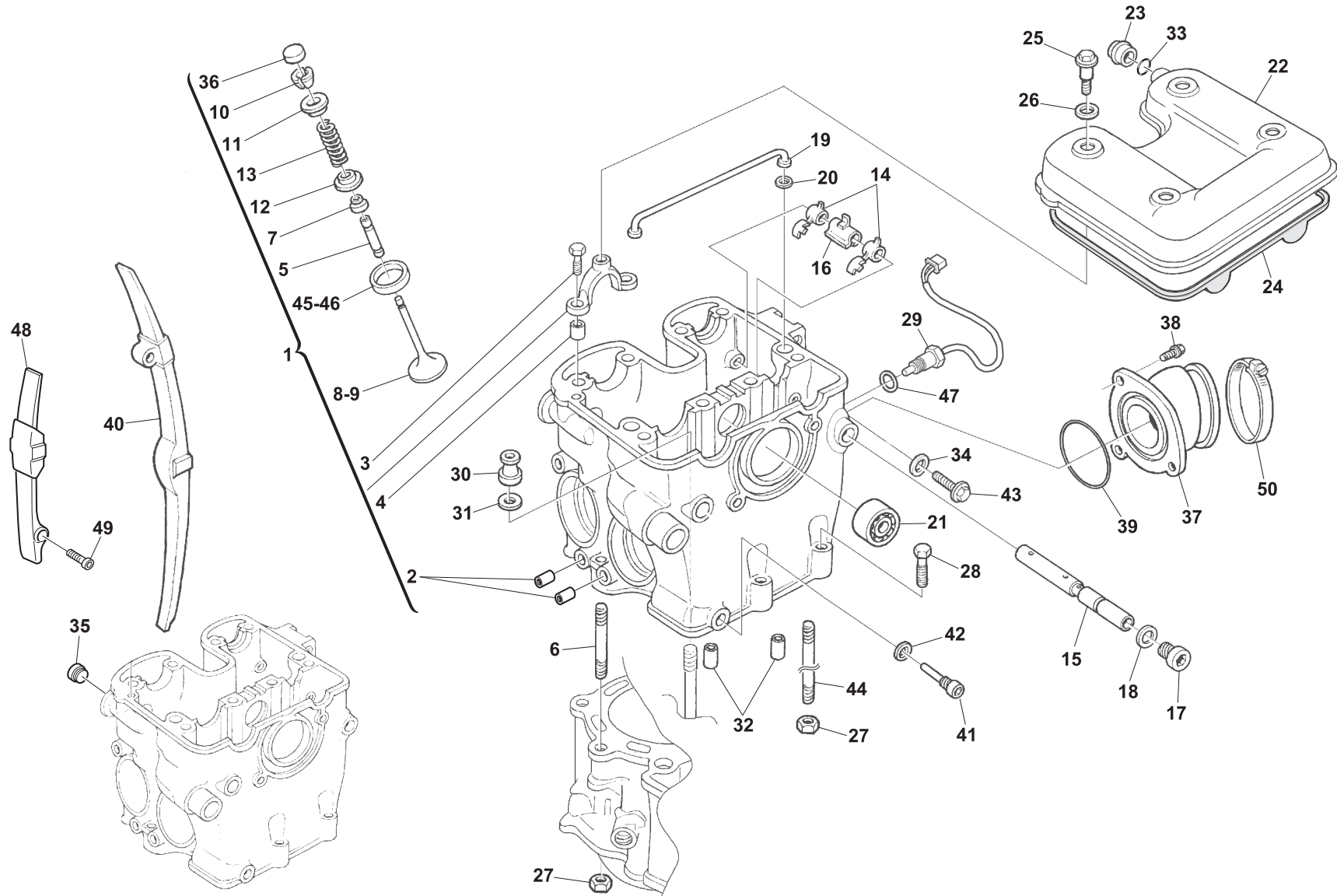



**Superdual 2017**
**TESTA CILINDRO - CYLINDER HEAD  
 CULASSE - ZYLINDERKOPF  
 CULATA**
TAVOLA  
DRAWING  
TABLE  
BILD  
TABLA**3**

Note Notes Notas	Pos. No. Index Pos.	N. Cod. Code No. Nr. Code Code Nr N. Cod.	Q.tà Q.ty M.ge C.ad	DENOMINAZIONE	NAME	DESIGNATION	BESHREIBUNG	DENOMINACION
	1	M000A00096	1	TESTA CILINDRO	HEAD, CYLINDER	CULASSE	ZYLINDERKOPF	CULATA
	2	800049792	4	INSERTO FILETTATO HELI-COIL	THREADED INSERT HELI-COIL	INSERTION FILETE HELI-COIL	GEWINDINSATZ HELI-COIL	ROSCA ROSCADA HELI-COIL
	3	8A0085071	8	VITE TCEI M6X1X25	SCREW TCEI M6X1X25	VIS TCEI M6X1X25	SCHRAUBE TCEI M6X1X25	TORNILLO TCEI M6X1X25
	4	161795501	8	BOCCOLA 8X6,4X6	BUSH 8X6.4X6	DOUILLE 8X6,4X6	BUCHSE 8X6,4X6	CASQUILLO 8X6,4X6
	5	8000A4158	2	GUIDAVALVOLA SCARICO 5 mm	GUIDE, EXHAUST VALVE 5 mm	GUIDE-SOUPAPE ECHAPPEMENT 5 mm	AUSLASSVENTILFUEHRUNG 5 mm	GUIA-VALVULA ESCAPE 5 mm
	5	8000A4159	2	GUIDAVALVOLA ASPIRAZIONE 5,5 mm	GUIDE INTAKE VALVE 5.5 mm	GUIDE-SOUPAPE D'ASPIRATION 5,5 mm	EINLASSVENTILFUEHRUNG 5,5 mm	GUIA-VALVULA ADMISION 5,5 mm
	6	800074836	2	PRIGIONIERO CILINDRO M8X51	STUD BOLT M8X51	GOUJON M8X51	STIFTSCHRAUBE M8X51	ESPARRAGO M8X51
	7	8000A4136	2	PARAOLIO VALVOLA 5 mm	SEAL VALVE STEM 5 mm	BAGUE D'ETENCHEITE SOUPAPE 5 mm	WELLENDICHTRING VENTIL 5 mm	RETEN DE ACEITE VALVULA 5 mm
	7	8000A4137	2	PARAOLIO VALVOLA 5,5 mm	SEAL VALVE STEM 5.5 mm	BAGUE D'ETENCHEITE SOUPAPE 5,5 mm	WELLENDICHTRING VENTIL 5,5 mm	RETEN DE ACEITE VALVULA 5,5 mm
	8	8000H4195	2	VALVOLA ASPIRAZIONE	VALVE, INTAKE	SOUPAPE ADMISSION	EINLASSVENTIL	VALVULA ADMISION
	9	8000H4194	2	VALVOLA SCARICO ACCIAIO	VALVE, EXHAUST STEEL	SOUPAPE D'ECHAPPEMENT ACIER	VENTIL, AUSLASS STHAL	VALVULA DE ESCAPE ACERO
	10	8000A4106	4	SEMICONO VALVOLA 5 mm	COTTER, VALVE 5 mm	DEMI-CLAVETTE SOUPAPE 5 mm	VENTILHALBKEGEL 5 mm	SEMICONO VALVULA 5 mm
	10	8000A4107	4	SEMICONO VALVOLA 5,5 mm	COTTER, VALVE 5.5 mm	DEMI-CLAVETTE SOUPAPE 5,5 mm	VENTILHALBKEGEL 5,5 mm	SEMICONO VALVULA 5,5 mm
	11	8000A4151	2	SCODELLINO MOLLA VALVOLA SCARICO 5 mm	RETAINER, EXHAUST VALVE SPRING 5 mm	FIXATION RESSORT SUPAPE ECHAPPEM. 5 mm	TELLER, AUSLASSVENTILFEDER 5 mm	RETEN, RESORTE VALVULA DESCARGA 5 mm
	11	8000A4157	2	SCODELLINO MOLLA VALVOLA ASPIRAZ. 5,5 mm	RETAINER, SPRING INTAKE VALVE 5.5 mm	FIXATION RESSORT SUPAPE ASPIRATION 5,5MM	TELLER, EINLASSVENTILFEDER 5,5 mm	RETEN, RESORTE VALVULAADMISION 5,5 mm
	12	800091578	2	SEDE MOLLA VALVOLA SCARICO	SEAT, SPRING EXHAUST	SIEGE RESSORT DU SOUPAPE ECHAPPEMENT	SITZ, AUSLASSVENTILFEDER	ASIEN TO MUELLE VALVULA ESCAPE
	12	8000A4135	2	SEDE MOLLA VALVOLA ASPIRAZIONE	SEAT, SPRING INTAKE	SIEGE RESSORT DU SOUPAPE ADMISSION	SITZ, ENLASS VENTILFEDER	ASIEN TO MUELLE VALVULA ADMISION
	13	8000A0568	4	MOLLA VALVOLA	SPRING, VALVE	RESSORT SOUPAPE	VENTILFEDER	MUELLE PARA VALVULA
	14	800091568	4	BILANCIERE	ARM ROCKER	CULBUTEUR	KIPPHEBEL	BALANCIN
	15	8000A5437	2	ASSE BILANCIERE	AXLE, VALVE ROCKER ARM	AXE CULBUTEURS	KIPPHEBELACHSE	EJE BALANCIN
	16	8B00A5435	1	DISTANZIALE A MOLLA 25,8 mm	SPACER, SPRING 25.8 mm	ENTRETOISE 25,8 mm	ABSTANDHALTER 25,8 mm	DISTANCIADOR 25,8 mm
	16	8C00A5435	1	DISTANZIALE A MOLLA 30,8 mm	SPACER, SPRING 30.8 mm	ENTRETOISE 30,8 mm	ABSTANDHALTER 30,8 mm	DISTANCIADOR 30,8 mm
	17	800099711	2	TAPPO DIN 908 M14X1,5	PLUG DIN 908 M14X1.5	BOUCHON DIN 908 M14X1,5	VERSCHLUSS DIN 908 M14X1,5	TAPON DIN 908 M14X1,5
	18	800047763	2	RONDELLA 17,9X14,2X1,5 mm	WASHER 17.9X14.2X1.5 mm	RONDELLE 17,9X14,2X1,5 mm	SCHEIBE 17,9X14,2X1,5 mm	ARANDELA 17,9X14,2X1,5 mm
	19	800099834	1	TUBO OLIO	HOSE, OIL	TUYAU HUILE	OELSCHLAUCH	MANGUERA ACEITE
	20	800091584	2	ANELLO O-RING 2018 1,78 D4,48	O-RING 2018 1.78 D4.48	JOINT TORIQUE 2018 1,78 D4,48	O-RING 2018 1,78 D4,48	JUNTA TORICA 2018 1,78 D4,48
	21	800034317	1	CUSCINETTO A SFERE 12X28X8	BEARING, BALL 12X28X8	ROULEMENT A BILLES 12X28X8	KUGELLAGER 12X28X8	COJINETE DE BOLAS 12X28X8
	22	M000P00098	1	COPERCHIO VALVOLE	COVER, CYLINDER HEAD	COUVERCLE CULASSE	DECKEL, ZYLINDERKOPF	CUBIERTA CULATA
	23	8000A7039	1	RACCORDO SFIATO	JOINT, BREATHER	RACCORD, RENIFLARD	ANSCHLUSS, BELUFTUNG	RACOR RESPIRADERO
	24	800099837	1	GUARNIZIONE COPERCHIO VALVOLE	GASKET CYLINDER HEAD COVER	JOINT, COUVERCLE CULASSE	DICHTUNG, ZYLINDERKOPFDECKEL	JUNTA CUBIERTA CULATA
	25	Z00091587	4	VITE	SCREW	VIS	SCHRAUBE	TORNILLO
	26	800091588	4	RONDELLA	WASHER	RONDELLE	SCHEIBE	ARANDELA
	27	Z00054700	2	DADO	NUT	ECROU	MUTTER	TUERCA

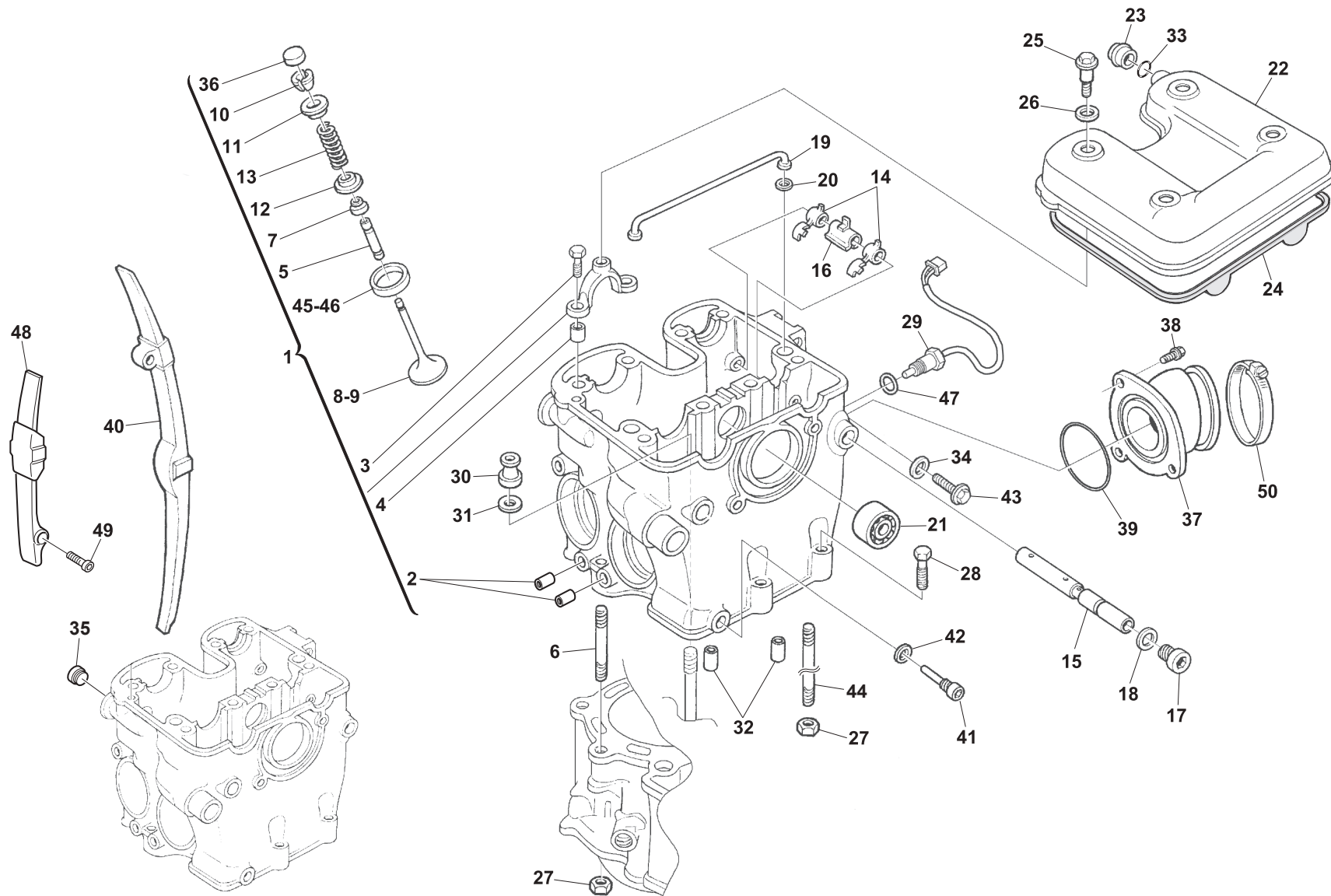



Superdual 2017

TESTA CILINDRO - CYLINDER HEAD  
CULASSE - ZYLINDERKOPF  
CULATA

TAVOLA  
DRAWING  
TABLE  
BILD  
TABLA

3

Note Notes Notes Marke Notas	Pos. No. N. Index Pos.	N. Cod. Code No. Nr. Code Code Nr N. Cod.	Q.tà Q.ty Q.te M.ge C.ad	DENOMINAZIONE	NAME	DESIGNATION	BESHREIBUNG	DENOMINACION
	28	Z00062730	2	VITE TE M6X1X30 CH8	SCREW TE M6X1X30 CH8	VIS TE M6X1X30 CH8	SCHRAUBE TE M6X1X30 CH8	TORNILLO TE M6X1X30 CH8
	28	ZE0067545	1	VITE TEF M6X1X40 CH8	SCREW TEF M6X1X40 CH8	VIS TEF M6X1X40 CH8	SCHRAUBE TEF M6X1X40 CH8	TORNILLO TEF M6X1X40 CH8
	29	8000H3649	1	SENSORE TEMPERATURA ACQUA	SENSOR WATER TEMPERATURE	CAPTEUR TEMPERATURE EAU	WASSERTEMPERATURFUEHLER	SENSOR TEMPERATURA AGUA
	30	800091589	4	DADO	NUT	ECROU	MUTTER	TUERCA
	31	Z00023374	4	RONDELLA	WASHER	RONDELLE	SCHEIBE	ARANDELA
	32	8000H0278	4	BOCCOLA	BUSH	DOUILLE	BUCHSE	BUJE
	33	800001199	1	ANELLO O-RING	O-RING	JOINT TORIQUE	O-RING	JUNTA TORICA
	34	62N015672	1	RONDELLA ALLUMINIO 10X5,1X1 mm	ALUMINIUM WASHER 10X5,1X1 mm	RONDELLE EN ALUMINIUM 10X5,1X1 mm	ALUMINIUM SCHEIBE 10X5,1X1 mm	ARANDELA DE ALUMINIO 10X5,1X1 mm
	35	800057196	1	TAPPO 12X6X10	PLUG 12X6X10	BOUCHON 12X6X10	VERSCHLUSS 12X6X10	TAPON 12X6X10
	36	8P00A4162	4	PASTIGLIA VALVOLA 2,30 mm	PAD, VALVE ADJUSTING 2.30 mm	PASTILLE REGLAGE CULBETEUR 2,30 mm	VENTILKAEPPOCHEN 2,30 mm	REGISTRO BALANCIN 2,30 mm
	36	8W00A4162	4	PASTIGLIA VALVOLA 2,60 mm	PAD, VALVE ADJUSTING 2.60 mm	PASTILLE REGLAGE CULBETEUR 2,60 mm	VENTILKAEPPOCHEN 2,60 mm	REGISTRO BALANCIN 2,60 mm
	36	8V00A4162	4	PASTIGLIA VALVOLA 2,55 mm	PAD, VALVE ADJUSTING 2.55 mm	PASTILLE REGLAGE CULBETEUR 2,55 mm	VENTILKAEPPOCHEN 2,55 mm	REGISTRO BALANCIN 2,55 mm
	36	8U00A4162	4	PASTIGLIA VALVOLA 2,50 mm	PAD, VALVE ADJUSTING 2.50 mm	PASTILLE REGLAGE CULBETEUR 2,50 mm	VENTILKAEPPOCHEN 2,50 mm	REGISTRO BALANCIN 2,50 mm
	36	8T00A4162	4	PASTIGLIA VALVOLA 2,45 mm	PAD, VALVE ADJUSTING 2.45 mm	PASTILLE REGLAGE CULBETEUR 2,45 mm	VENTILKAEPPOCHEN 2,45 mm	REGISTRO BALANCIN 2,45 mm
	36	8R00A4162	4	PASTIGLIA VALVOLA 2,35 mm	PAD, VALVE ADJUSTING 2.35 mm	PASTILLE REGLAGE CULBETEUR 2,35 mm	VENTILKAEPPOCHEN 2,35 mm	REGISTRO BALANCIN 2,35 mm
	36	8N00A4162	4	PASTIGLIA VALVOLA 2,25 mm	PAD, VALVE ADJUSTING 2.25 mm	PASTILLE REGLAGE CULBETEUR 2,25 mm	VENTILKAEPPOCHEN 2,25 mm	REGISTRO BALANCIN 2,25 mm
	36	8M00A4162	4	PASTIGLIA VALVOLA 2,20 mm	PAD, VALVE ADJUSTING 2.20 mm	PASTILLE REGLAGE CULBETEUR 2,20 mm	VENTILKAEPPOCHEN 2,20 mm	REGISTRO BALANCIN 2,20 mm
	36	8L00A4162	4	PASTIGLIA VALVOLA 2,15 mm	PAD, VALVE ADJUSTING 2.15 mm	PASTILLE REGLAGE CULBETEUR 2,15 mm	VENTILKAEPPOCHEN 2,15 mm	REGISTRO BALANCIN 2,15 mm
	36	8K00A4162	4	PASTIGLIA VALVOLA 2,10 mm	PAD, VALVE ADJUSTING 2.10 mm	PASTILLE REGLAGE CULBETEUR 2,10 mm	VENTILKAEPPOCHEN 2,10 mm	REGISTRO BALANCIN 2,10 mm
	36	8H00A4162	4	PASTIGLIA VALVOLA 2,00 mm	PAD, VALVE ADJUSTING 2.00 mm	PASTILLE REGLAGE CULBETEUR 2,00 mm	VENTILKAEPPOCHEN 2,00 mm	REGISTRO BALANCIN 2,00 mm
	36	8G00A4162	4	PASTIGLIA VALVOLA 1,95 mm	PAD, VALVE ADJUSTING 1.95 mm	PASTILLE REGLAGE CULBETEUR 1,95 mm	VENTILKAEPPOCHEN 1,95 mm	REGISTRO BALANCIN 1,95 mm
	36	8F00A4162	4	PASTIGLIA VALVOLA 1,90 mm	PAD, VALVE ADJUSTING 1.90 mm	PASTILLE REGLAGE CULBETEUR 1,90 mm	VENTILKAEPPOCHEN 1,90 mm	REGISTRO BALANCIN 1,90 mm
	36	8E00A4162	4	PASTIGLIA VALVOLA 1,85 mm	PAD, VALVE ADJUSTING 1.85 mm	PASTILLE REGLAGE CULBETEUR 1,85 mm	VENTILKAEPPOCHEN 1,85 mm	REGISTRO BALANCIN 1,85 mm
	36	8D00A4162	4	PASTIGLIA VALVOLA 1,80 mm	PAD, VALVE ADJUSTING 1.80 mm	PASTILLE REGLAGE CULBETEUR 1,80 mm	VENTILKAEPPOCHEN 1,80 mm	REGISTRO BALANCIN 1,80 mm
	36	8C00A4162	4	PASTIGLIA VALVOLA 1,75 mm	PAD, VALVE ADJUSTING 1.75 mm	PASTILLE REGLAGE CULBETEUR 1,75 mm	VENTILKAEPPOCHEN 1,75 mm	REGISTRO BALANCIN 1,75 mm
	36	8B00A4162	4	PASTIGLIA VALVOLA 1,70 mm	PAD, VALVE ADJUSTING 1.70 mm	PASTILLE REGLAGE CULBETEUR 1,70 mm	VENTILKAEPPOCHEN 1,70 mm	REGISTRO BALANCIN 1,70 mm
	36	8A00A4162	4	PASTIGLIA VALVOLA 1,65 mm	PAD, VALVE ADJUSTING 1.65 mm	PASTILLE REGLAGE CULBETEUR 1,65 mm	VENTILKAEPPOCHEN 1,65 mm	REGISTRO BALANCIN 1,65 mm
	36	8000A4162	4	PASTIGLIA VALVOLA 1,60 mm	PAD, VALVE ADJUSTING 1.60 mm	PASTILLE REGLAGE CULBETEUR 1,60 mm	VENTILKAEPPOCHEN 1,60 mm	REGISTRO BALANCIN 1,60 mm
	36	8S00A4162	4	PASTIGLIA VALVOLA 2,40 mm	PAD, VALVE ADJUSTING 2.40 mm	PASTILLE REGLAGE CULBETEUR 2,40 mm	VENTILKAEPPOCHEN 2,40 mm	REGISTRO BALANCIN 2,40 mm
	36	8J00A4162	4	PASTIGLIA VALVOLA 2,05 mm	PAD, VALVE ADJUSTING 2.05 mm	PASTILLE REGLAGE CULBETEUR 2,05 mm	VENTILKAEPPOCHEN 2,05 mm	REGISTRO BALANCIN 2,05 mm
	37	8000H0879	1	COLLETTORE ASPIRAZIONE	MANIFOLD, INTAKE	COLLECTEUR ADMISSION	EINSATZ KRUEMMER	COLECTOR ADMISION
	38	60ND02509	3	VITE TCEI M6X1X20 CH5	SCREW TCEI M6X1X20 CH5	VIS TCEI M6X1X20 CH5	SCHRAUBE TCEI M6X1X20 CH5	TORNILLO TCEI M6X1X20 CH5
	39	8A0028553	1	ANELLO O-RING 3200 2,62X50,47	O-RING 3200	JOINT TORIQUE 3200	O-RING 3200	JUNTA TORICA 3200

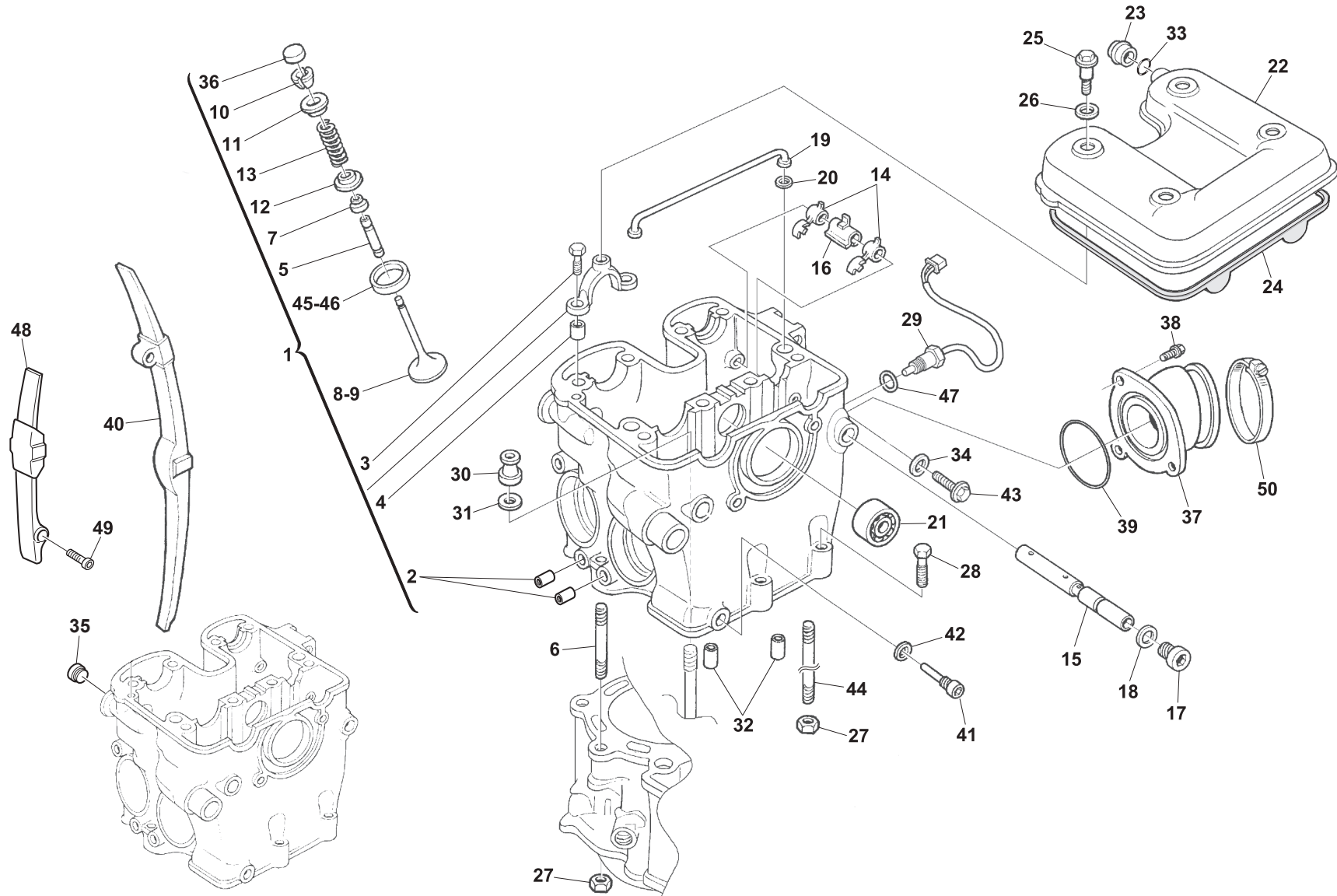



**TESTA CILINDRO - CYLINDER HEAD  
CULASSE - ZYLINDERKOPF  
CULATA**

Note Notes Notes Marke Notas	Pos. No. Index Pos.	N. Cod. Code No. Nr. Code Code Nr N. Cod.	Q.tà Q.ty Q.te M.ge C.ad	DENOMINAZIONE	NAME	DESIGNATION	BESHREIBUNG	DENOMINACION
	40	8000H1783	1	PATTINO GUIDA CATENA DISTRIBUZIONE	GUIDE, TIMING CHAIN	PATIN GUIDE CHAINE DISTRIBUTION	STEUERKETTENFUEHRUNG	GUIA CADENA DISTRIBUCION
	41	161535902	2	VITE	SCREW	VIS	SCHRAUBE	TORNILLO
	42	800045194	1	RONDELLA 14X8,2X1	WASHER 14X8.2X1	RONDELLE 14X8,2X1	SCHEIBE 14X8,2X1	ARANDELA 14X8,2X1
	43	ZD0067997	1	VITE TEF M5X0,8X8 CH8	SCREW TEF M5X0,8X8 CH8	VIS TEF M5X0,8X8 CH8	SCHRAUBE TEF M5X0,8X8 CH8	TORNILLO TEF M5X0,8X8 CH8
	44	8B0081650	4	PRIGIONIERO M10X185 mm	STUD BOLT M10X185 mm	GOUJON M10X185 mm	STIFTSCHRAUBE M10X185 mm	ESPARRAGO M10X185 mm
	45	8000A5450	2	SEDE VALVOLA ASPIRAZIONE	SEAT, INTAKE VALVE	SIEGE SOUPAPE ASPIRATION	SITZRING, EINLASSVENTIL	ASIEN TO VALVULA ADMISION
	46	8000A5449	2	SEDE VALVOLA SCARICO	SEAT, EXHAUST VALVE	SIEGE SOUPAPE ECHAPPEMENT	SITZRING, AUSLASSVENTIL	ASIEN TO VALVULA ESCAPE
	47	8A0023108	2	ANELLO O-RING 2037 1,78X9,25	O RING 2037 1.78X9.25	JOINT TORIQUE 2037 1,78X9,25	O-RING 2037 1,78X9,25	JUNTA TORICA 2037 1,78X9,25
	48	8000H1782	1	PATTINO TENDICATENA DISTRIBUZIONE	TENSIONER, CAM CHAIN	PATIN TENDEUR CHAINE DISTRIBUTION	STEUERKETTENGLEITFUEHRUNG	PATIN TENSOR CADENA DISTRIBUCION
	49	161535902	2	VITE	SCREW	VIS	SCHRAUBE	TORNILLO
	50	8000A7693	1	FASCETTA	CLAMP	COLLIER	KLAMMER	ABRAZADERA

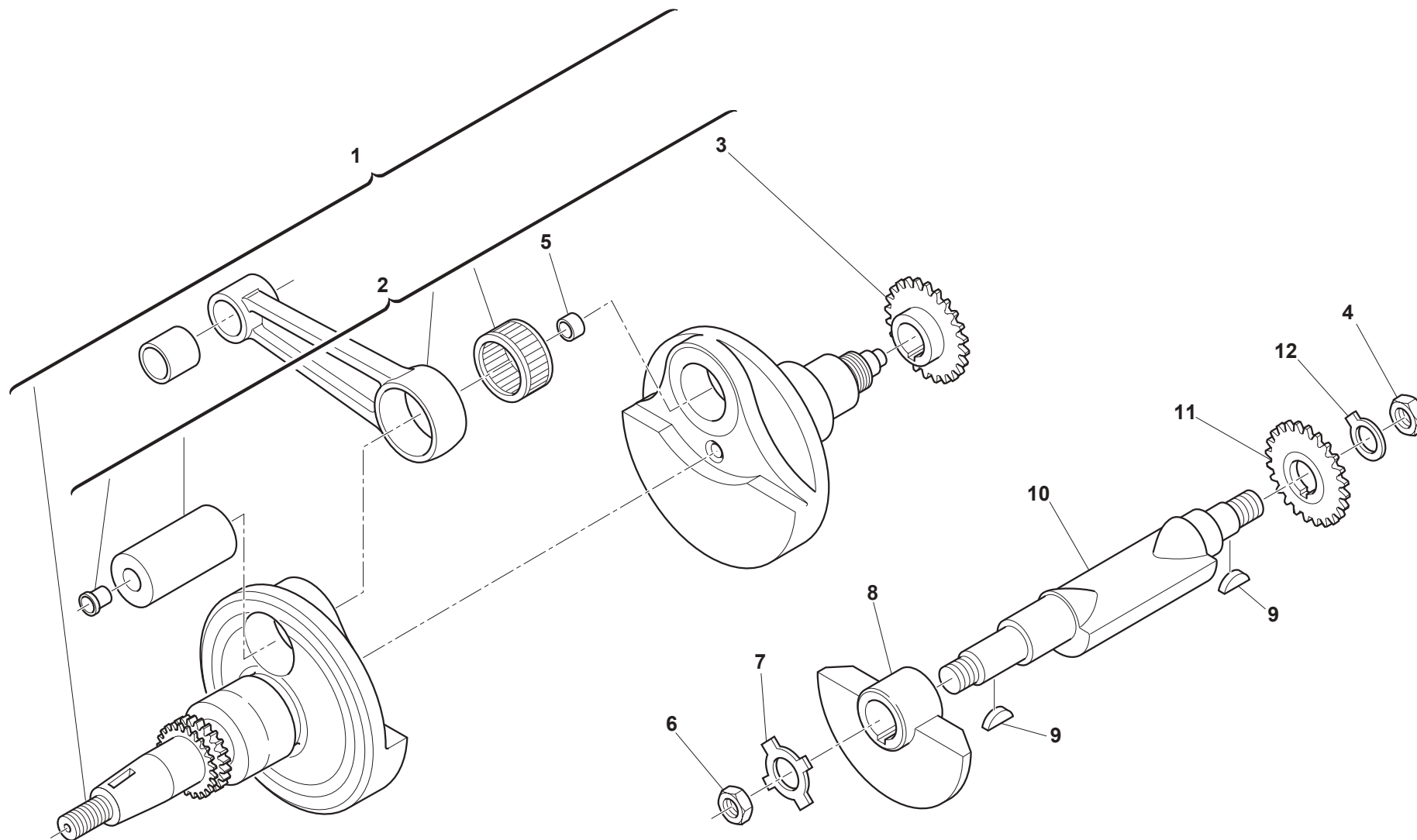



Superdual 2017

MANOVELLISMO - CRANKSHAFT  
VILEBREQUIN - KURBELWELLE  
CIGÜEÑAL

TAVOLA  
DRAWING  
TABLE  
BILD  
TABLA

4

Note Notes Notes Marke Notas	Pos. No. Index Pos.	N. Cod. Code No. Nr. Code Code Nr N. Cod.	Q.tà Q.ty Q.te M.ge C.ad	DENOMINAZIONE	NAME	DESIGNATION	BESHREIBUNG	DENOMINACION
	1	8000H7033	1	ALBERO MOTORE	CRANKSHAFT	VILEBREQUIN	KURBELWELLE	CIGUENAL
	2	8000H7035	1	BIELLA	CONNECTING ROD	BIELLE	PLEUELSTANGE	BIELA
	3	M000P00001	1	INGRANAGGIO CONDUTTORE Z39	GEAR DRIVE T39	ENGRENAGE MENANT D39	TREIBENDES ZAHNRAD Z39	ENGRANAJE CONDUCTOR D39
	4	800003170	1	DADO INGRANAGGIO CONTRALBERO	NUT	ECROU	MUTTER	TUERCA
	5	800057196	2	TAPPO 12X6X10	PLUG 12X6X10	BOUCHON 12X6X10	VERSCHLUSS 12X6X10	TAPON 12X6X10
	6	800071031	1	DADO FISSAGGIO MASSA	NUT	ECROU	MUTTER	TUERCA
	7	800071034	1	RONDELLA DI SICUREZZA	WASHER, LOCK	RONDELLE VERROULAGE	SICHERUNGSSCHEIBE	ARANDELA CIERRE
	8	800071024	1	MASSA CONTROROTANTE	COUNTERWEIGHT WITH GEARS	CONTRE MASSE	GEGENMASSE	CONTRAMASA
	9	151371301	2	CHIAVETTA WOODRUFF	KEY, WOODRUFF	CLAVETTE, DEMI-LUNE WOODRUFF	EINLEGE KEIL, WOODRUFF	CHAVETA WOODRUFF
	10	800071023	1	CONTRALBERO BILANCIAMENTO	BALANCER, CRANK	ARBRE BALANCIEUR	WELLE, AUSGLEICH	ARBOL BALANCADOR
	11	M000P00002	1	INGRANAGGIO CONDOTTO Z39	GEAR, DRIVEN T39	ENGRENAGE ENTRAINE D39	ANGETRIEBENES ZAHNRAD Z39	ENGRANAJE ACCIONADO D39
	12	800071035	1	RONDELLA DI SICUREZZA	WASHER, LOCK	RONDELLE VERROULAGE	SICHERUNGSSCHEIBE	ARANDELA CIERRE

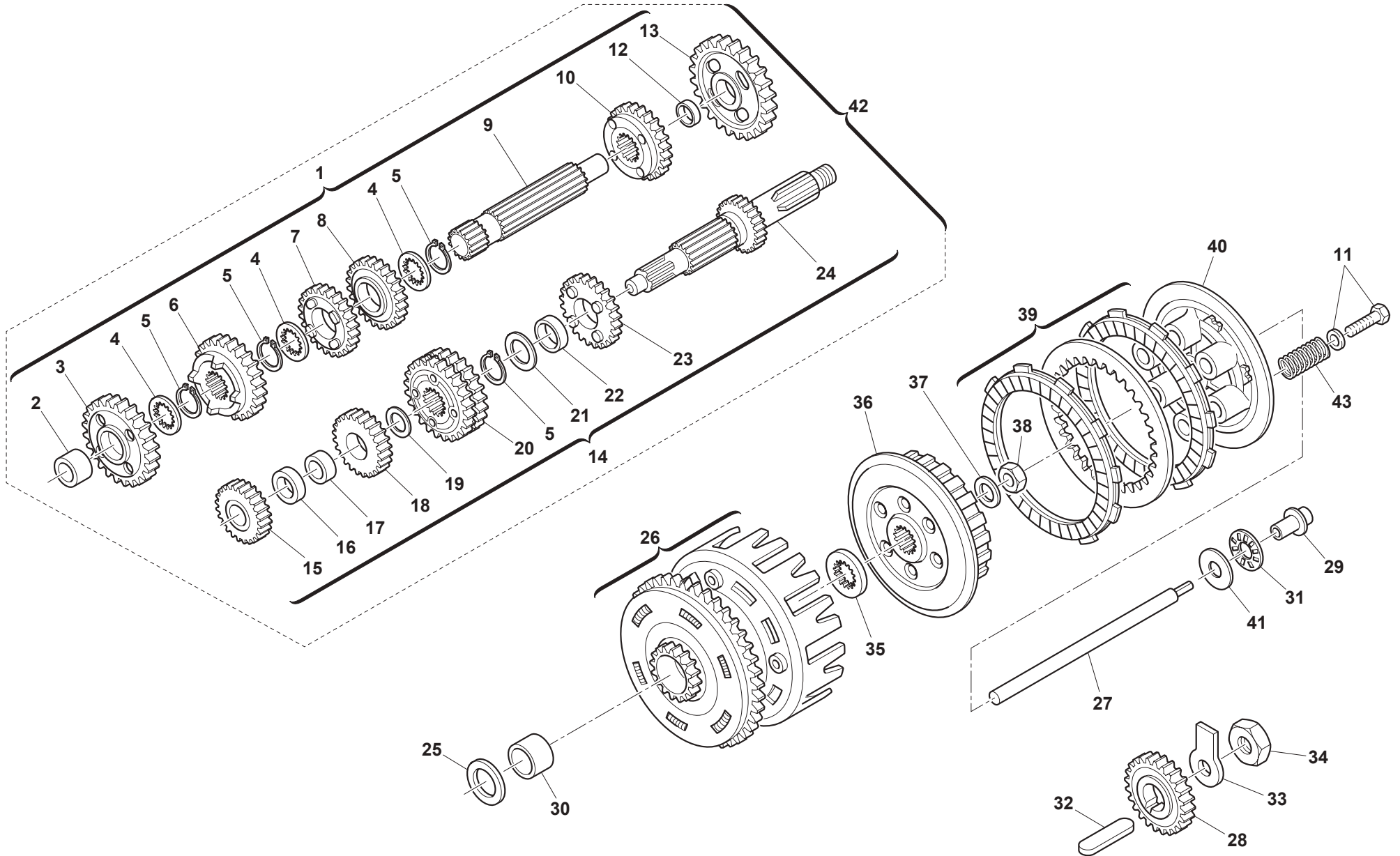



**Superdual 2017**

**TRASMISSIONE PRIMARIA, FRIZIONE - PRIMARY DRIVE, CLUTCH  
TRANSMISSION PRIMAIRE, EMBRAYAGE  
PRIMÄRÜBERSETZUNG, KUPPLUNG - TRANSMISION PRIMARIA, EMBRAGUE**

TAVOLA  
DRAWING  
TABLE  
BILD  
TABLA**5**

Note Notes Notes Marke Notas	Pos. No. N. Index Pos.	N. Cod. Code No. Nr. Code Code Nr N. Cod.	Q.tà Q.ty M.ge C.ad	DENOMINAZIONE	NAME	DESIGNATION	BESHREIBUNG	DENOMINACION
	1	M000A00706	1	ALBERO SECONDARIO COMPLETO	COUNTER SHAFT ASSY	ARBRE SECONDAIRE COMPLET	NEBENGETRIEBEWELLE KOMPL.	ARBOL SECONDARIO CAMBIO COMPLETO
	2	800063822	1	BOCCOLA 28X25X7	BUSH 28X25X7	DOUILLE 28X25X7	BUCHSE 28X25X7	BUJE 28X25X7
	3	800074864	1	INGRANAGGIO CONDOTTO 2A Z29	DRIVEN GEAR 2ND SPEED T29	ENGRENAGE ENTRAINE 2EME VITESSE D29	ANGETRIEBENES ZAHNRAD 2. GESCHWIND.Z29	ENGRANAJE ACCIONADO 2NDA VELOCIDAD D29
	4	161171701	3	RONDELLA	WASHER	RONDELLE	SCHEIBE	ARANDELA
	5	66N021211	4	ANELLO SEEGER 25mm DIN471	CIRCLIP 25mm DIN471	CIRCLIP 25mm DIN471	SPRENGRING 25mm DIN471	ANILLO SEEGER 25mm DIN471
	6	M000P00708	1	INGRANAGGIO CONDOTTO 3A Z27	DRIVEN GEAR 3RD SPEED T27	ENGRENAGE ENTRAINE 3EME VITESSE D27	ANGETRIEBENES ZAHNRAD 3. GESCHWIND. Z27	ENGRANAJE ACCIONADO 3ERA VELOCIDAD D27
	7	M000P00709	1	INGRANAGGIO CONDOTTO 6A	DRIVEN GEAR 6TH SPEED	ENGRENAGE ENTRAINE 6EME VITESSE	ANGETRIEBENES ZAHNRAD 6. GESCHWIND.	ENGRANAJE ACCIONADO 6A VELOCIDAD
	8	M000P00710	1	INGRANAGGIO CONDOTTO 5A Z22	DRIVEN GEAR 5TH SPEED T22	ENGRENAGE ENTRAINE 5EME VITESSE D22	ANGETRIEBENES ZAHNRAD 5. GESCHWIND. Z27	ENGRANAJE ACCIONADO 5A VELOCIDAD D22
	9	M000P00707	1	ALBERO SECONDARIO	SECONDARY SHAFT	ARBRE SECONDAIRE	NEBEN WELLE	ARBOL SECONDARIO
	10	M000P00711	1	INGRANAGGIO CONDOTTO 4A Z24	DRIVEN GEAR 4TH SPEED T:24	ENGRENAGE ENTRAINE 4EME VITESSE D24	ANGETRIEBENES ZAHNRAD 4. GESCHWIND. Z24	ENGRANAJE ACCIONADO 4A VELOCIDAD D24
	11	M000P00464	6	VITE CON RONDELLA	SCREW WITH WASHER	VIS AVEC RONDELLE	SCHRAUBE MIT SCHEIBE	TORNILLO CON ARANDELA
	12	161241501	1	BRONZINA INGRANAGGIO	BUSH, GEAR	COUSSINET ENGRANAGE	GLEITLAGER, ZHANRAD	COJINETE PLANO ENGRANAJE
	13	800074862	1	INGRANAGGIO CONDOTTO 1A Z34	DRIVEN GEAR 1ST SPEED T34	ENGRENAGE ENTRAINE 1ERE VITESSE D34	ANGETRIEBENES ZAHNRAD 1. GESCHWIND. Z34	ENGRANAJE ACCIONADO 1ERA VELOCIDAD D34
	14	M000A00703	1	ALBERO PRIMARIO COMPLETO	MAIN SHAFT ASSY	ARBRE PRIMAIRE COMPLET	KOMPLETTE HAUPTWELLE	ARBOL PRIMARIO COMPLETO
	15	800074863	1	INGRANAGGIO CONDUTTORE 2A Z16	GEAR INPUT 2ND 16T	ENGRENAGE MENANT 2EME VITESSE D16	TREIBENDES ZAHNRAD 2. GESCHWIND. Z16	ENGRANAJE CONDUCTOR 2NDA VELOCIDAD D16
	16	161248101	1	DISTANZIALE	SPACER	ENTRETOISE	DISTANZSTÜCK	SEPARADOR
	17	161248001	1	BRONZINA INGRANAGGIO	BUSH, GEAR	COUSSINET ENGRANAGE	GLEITLAGER, ZHANRAD	COJINETE PLANO ENGRANAJE
	18	800079688	1	INGRANAGGIO CONDUTTORE 3A Z20	GEAR DRIVE 3RD SPEED T20	ENGRENAGE MENANT 3EME VITESSE D20	TREIBENDES ZAHNRAD 3. GESCHWIND. Z20	ENGRANAJE CONDUCTOR 3ERA VELOCIDAD D20
	19	161284201	1	RONDELLA	WASHER	RONDELLE	SCHEIBE	ARANDELA
	20	M000P00705	1	INGRANAGGIO CONDUTTORE 5A-6A	GEAR DRIVE 5-6TH SPEED	ENGRENAGE MENANT 5-6EME VITESSE	TREIBENDES ZAHNRAD 5-6, GESCHWIND.	ENGRANAJE CONDUCTOR 5-6A VEL.
	21	8H0036022	1	RONDELLA RASAMENTO 32X25,1X1,0 mm	THRUST WASHER 32X25,1X1,0 mm	RONDELLE DE BUTEE 32X25,1X1,0 mm	DISTANZSCHEIBE 32X25,1X1,0 mm	ARANDELA DE SEPARACION 32X25,1X1,0 mm
	22	800063821	1	BOCCOLA 28X25X9,9	BUSH 28X25X9,9	DOUILLE 28X25X9,9	BUCHSE 28X25X9,9	BUJE 28X25X9,9
	23	800079686	1	INGRANAGGIO CONDUTTORE 4A Z22	GEAR, 4TH DRIVE NT22	ENGRENAGE MENANT 4EME VITESSE D22	TREIBENDES ZAHNRAD 4. GESCHWIND. Z22	ENGRANAJE CONDUCTOR 4A VELOCIDAD D22
	24	M000P00704	1	ALBERO PRIMARIO Z13	MAIN SHAFT T13	ARBRE PRIMAIRE D13	HAUPTWELLE Z13	ARBOL PRIMARIO CAMBIO D13
	25	8E0030053	1	RONDELLA RASAMENTO 38X25,2	THRUST WASHER 38X25,2	RONDELLE DE BUTEE 38X25,2	DISTANZSCHEIBE 38X25,2	ARANDELA DE SEPARACION 38X25,2
	26	8000H2945	1	ASSIEME INGRANAGGIO CONDOTTO	GEAR, DRIVEN ASSY	ENGRENAGE ENTRAINE COMPLETE	ANGETRIEBENES ZAHNRAD	ENGRANAJE ACCIONADO COMPLETO
	27	8000H5375	1	ASTINA SPINGIFRIZIONE	ROD, CLUTCH PUSH	TIGE POUSSEE EMBRAYAGE	KUPPLUNGSGESTAENGE	VARILLA EMPUJE DISCO EMBRAGUE
	28	800097935	1	INGRANAGGIO CONDUTTORE Z 32	GEAR DRIVE T32	ENGRENAGE MENANT D32	TREIBENDES ZAHNRAD Z32	ENGRANAJE CONDUCTOR D32
	29	8000A9749	1	PUNTALINO FRIZIONE	PIECE, CLUTCH PUSH	BARRE PRESSION	DRUCKSTANGE	PISTON BOMBIN EMBRAGUE
	30	161538802	1	BOCCOLA INGRANAGGIO CONDOTTO 28X25 mm	BUSH 28X25 mm	DOUILLE 28X25 mm	BUCHSE 28X25 mm	BUJE 28X25 mm
	31	800035780	1	CUSCINETTO ASSIALE REGGISPINTA	BEARING, THRUST	ROULEMENT BUTEE	DRUCKLAGER	COJINETE EMPUJADOR
	32	800022426	1	CHIAVETTA INGRANAGGIO CONDUTTORE	KEY	CLAVETTE	KEIL	CHAVETA
	33	800086007	1	RONDELLA DI SICUREZZA	WASHER, LOCK	RONDELLE VERROULAGE	SICHERUNGSSCHEIBE	ARANDELA CIERRE

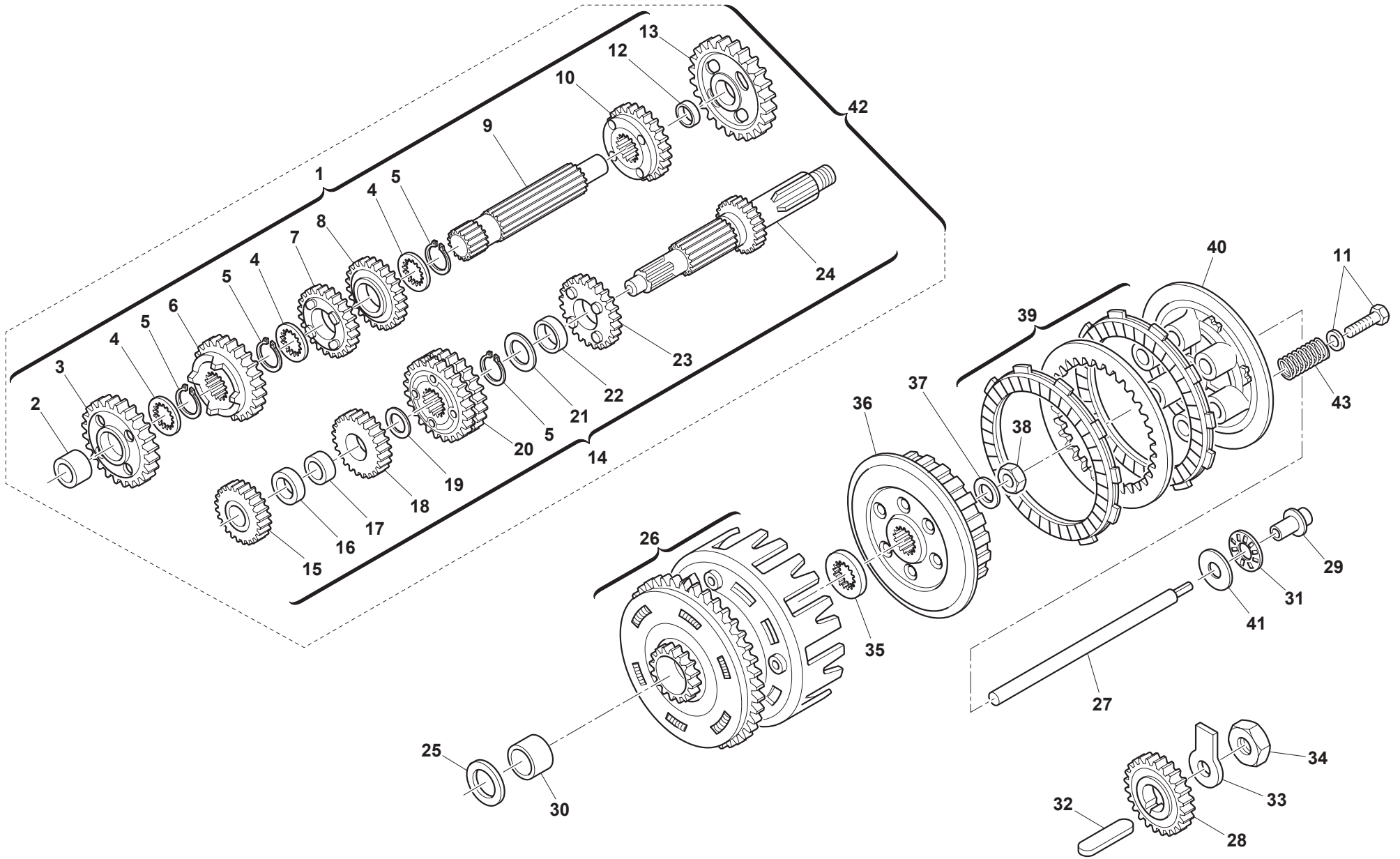

**TRASMISSIONE PRIMARIA, FRIZIONE - PRIMARY DRIVE, CLUTCH  
TRANSMISSION PRIMAIRE, EMBRAYAGE  
PRIMÄRÜBERSETZUNG, KUPPLUNG - TRANSMISSION PRIMARIA, EMBRAGUE**

Note Notes Notes Marke Notas	Pos. No. N. Index Pos.	N. Cod. Code No. Nr. Code Code Nr N. Cod.	Q.tà Q.ty Q.te M.ge C.ad	DENOMINAZIONE	NAME	DESIGNATION	BESHREIBUNG	DENOMINACION
	34	800086006	1	DADO M24X1,25	NUT M24X1.25	ECROU M24X1,25	MUTTER M24X1,25	TUERCA M24X1,25
	35	800038350	1	RONDELLA 46X22X19	WASHER 46X22X19	RONDELLE 46X22X19	SCHEIBE 46X22X19	ARANDELA 46X22X19
	36	800085390	1	MOZZETTO FRIZIONE	BOSS, CLUTCH	MOYEU EMBRAYAGE PORTE-DISQUE	KUPPLUNGSSCHEIBENHALTERNABE	CUBO EMBRAGUE PORTA-DISCOS
	37	800036857	1	RONDELLA DI SICUREZZA 18 mm	WASHER, LOCK 18 mm	RONDELLE VERROULAGE 18 mm	SICHERUNGSSCHEIBE 18 mm	ARANDELA CIERRE 18 mm
	38	800036856	1	DADO M18X1	NUT M18X1	ECROU M18X1	MUTTER M18X1	TUERCA M18X1
	39	8000A9764	1	SERIE DISCHI FRIZIONE	CLUTCH DISC SET	JEU DISQUES EMBRAYAGE	KUPPLUNGSSCHEIBENSATZ	JUEGO DISCOS EMBRAGUE
	40	800048138	1	PIATTO SPINGIDISCHI FRIZIONE	DISC, CLUTCH PRESSURE	DISQUE POUSSEE EMBRAYAGE	ANDRUECKTELLER KUPPLUNGSSCHEIBE	EMPUJADOR DISCO EMBRAGUE
	41	800035781	1	RALLA CUSCINETTO ASSIALE	WASHER, AXIAL BERING	RONDELLE ROULEMENT BUTEE	SCHEIBE DRUCKLAGER	ARANDELA COJINETE EMPUJADOR
	42	M000A00702	1	CAMBIO	GEARBOX ASSY	BOITE A VITESSES, COMPLETE	GETRIEBEGEHAEUSE, KOMPLETT	CAMBIO COMPLETO
	43	8000A0730	6	MOLLA FRIZIONE	SPRING, CLUTCH	RESSORT EMBRAYAGE	KUPPLUNGSFEDER	MUELLE EMBRAGUE

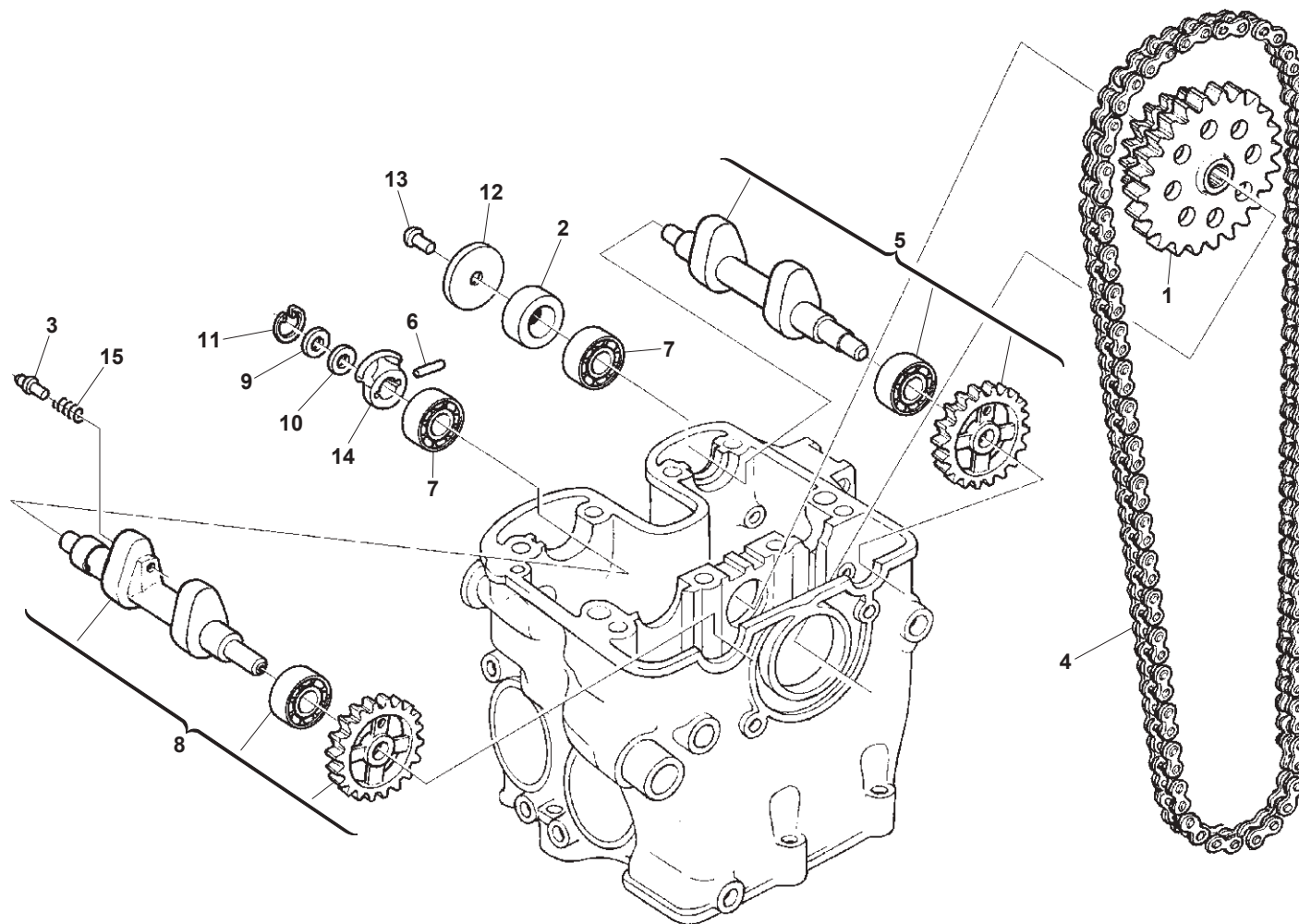



Superdual 2017

**DISTRIBUZIONE - VALVE TIMING**  
**DISTRIBUTION - VENTILSTEUERUNG**  
**DISTRIBUCION**

TAVOLA  
DRAWING  
TABLE  
BILD  
TABLA

6

Note Notes Marke Notas	Pos. No. Index Pos.	N. Cod. Code No. Nr. Code Code Nr N. Cod.	Q.tà Q.ty Q.te M.ge C.ad	DENOMINAZIONE	NAME	DESIGNATION	BESHREIBUNG	DENOMINACION
	1	8000H0986	1	INGRANAGGIO RINVIO DISTRIBUZIONE Z33/34	GEAR, TIMING T33/34	ENGRANAGE DISTRIBUTION D33/34	STEUERZAHNRAD Z33/34	ENGRANAJE DISTRIBUCION D33/34
	2	8000A6271	1	DISTANZIALE	SPACER	ENTRETOISE	ABSTANDHALTER	DISTANCIADOR
	3	800099700	1	PERNO	PIN	PIVOT	BOLZEN	PERNO
	4	8C00H0987	1	CATENA DISTRIBUZIONE	CHAIN, TIMING	CHAINE DISTRIBUTION	STEUERKETTE	CADENA DISTRIBUCION
	5	8000A5595	1	ALBERO A CAMME ASPIRAZIONE	CAM SHAFT, INTAKE	ARBRE A CAMES ASPIRATION	ENLASS NOCKENWELLE	ARBOL LEVAS ADMISION
	6	800099701	1	RULLINO B4X21,8	ROLLER B4X21.8	ROULEAU B4X21,8	ROLLE B4X21,8	RULO B4X21,8
	7	800034317	2	CUSCINETTO A SFERE 12X28X8	BEARING, BALL 12X28X8	ROULEMENT A BILLES 12X28X8	KUGELLAGER 12X28X8	COJINETE DE BOLAS 12X28X8
	8	8000A4953	1	ALBERO A CAMME SCARICO	CAM SHAFT, EXHAUST	ARBRE A CAMES ECHAPPEMENT	AUSLASS NOCKENWELLE	ARBOL LEVAS ESCAPE
	9	8A00H0597	1	RONDELLA RASAMENTO 16X19,2 X0,8	WASHER. THRUST 16X19.2 X0.8	RONDELLE DE BUTEE 16X19,2 X0,8	DISTANZSCHEIBE 16X19,2 X0,8	ARANDELA DE SEPARACION 16X19,2 X0,8
	10	8000H0597	1	RONDELLA RASAMENTO 16X19,2X1	WASHER. THRUST 16X19.2X1	RONDELLE DE BUTEE 16X19,2X1	DISTANZSCHEIBE 16X19,2X1	ARANDELA DE SEPARACION 16X19,2X1
	11	66N021205	1	ANELLO SEEGER 16 mm	CIRCLIP 16 mm	CIRCLIP 16 mm	SEEGERRING 16 mm	ANILLO SEEGER 16 mm
	12	800099703	1	DISCO CENTRIFUGO	CENTRIFUGAL DISC	DISQUE CENTRIFUGE	SCHEIBE	DISCO CENTRIFUGO
	13	Z00055699	1	VITE TCEI M6X1X10	SCREW TCEI M6X1X10	VIS TCEI M6X1X10	SCHRAUBE TCEI M6X1X10	TORNILLO TCEI M6X1X10
	14	8000A8994	1	MASSA ALZAVOLVA	WEIGHT, VALVE LIFTER	MASSELOTTE DECOMPRESSEUR	GEWICHT, DEKOMPRESSION	MASA DECOMPRESION
	15	800099699	1	MOLLA	SPRING	RESSORT	FEDER	MUELLE

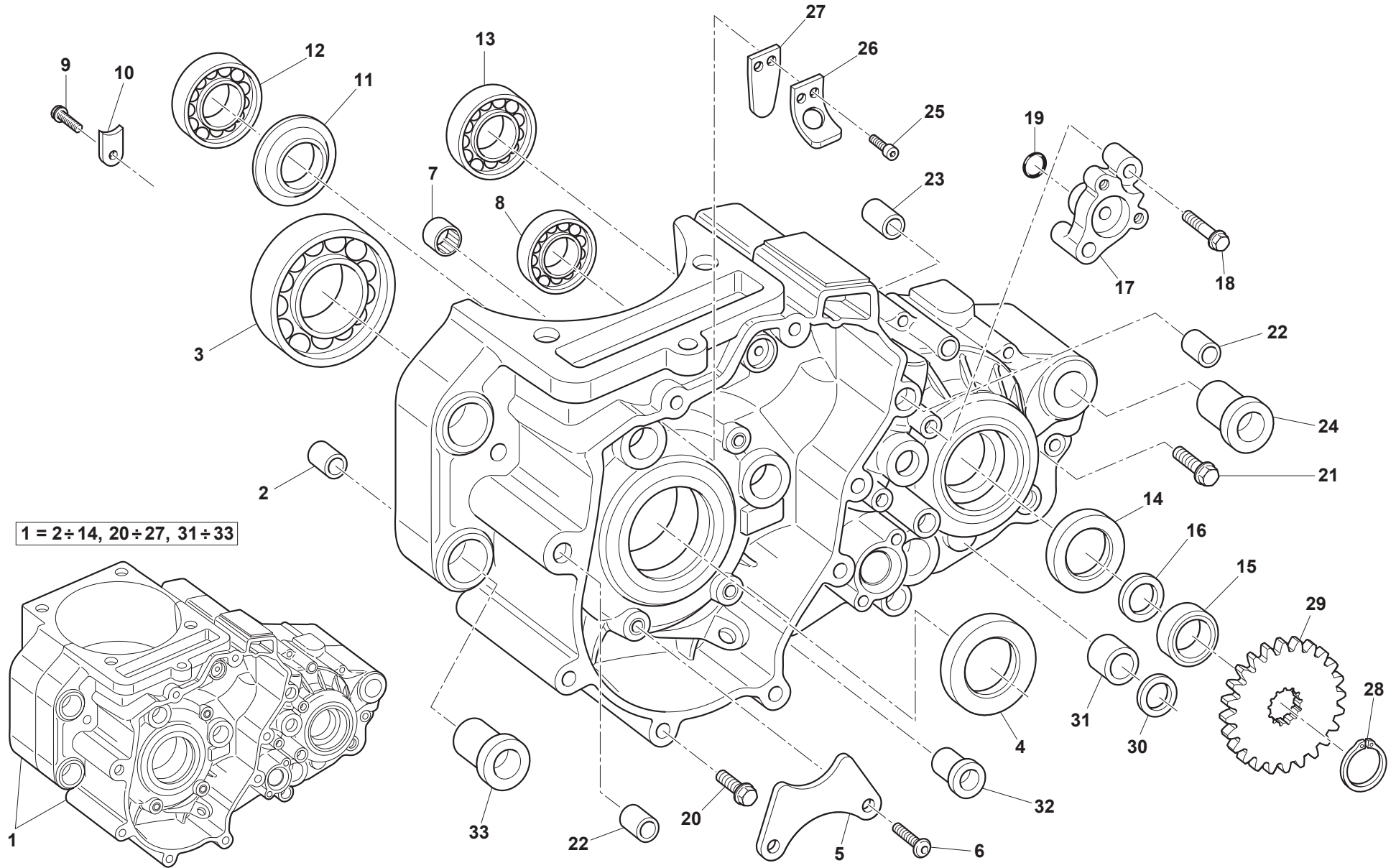

**Superdual 2017**

**SEMICARTER SINISTRO - L.H. HALF CRANKCASE**  
**CARTER G. - GEHAUSEDECKEL L.**  
**BANCADA IZQ.**

TAVOLA  
DRAWING  
TABLE  
BILD  
TABLA

**7**

Note Notes Notes Marke Notas	Pos. No. N. Index Pos.	N. Cod. Code No. Nr. Code Code Nr N. Cod.	Q.tà Q.ty M.ge C.ad	DENOMINAZIONE	NAME	DESIGNATION	BESHREIBUNG	DENOMINACION
	1	M000A00102	1	CARTER MOTORE	CRANKCASE SET	CARTER MOTEUR	KURBELWELLENGEHAUSE	CARTER MOTOR
	2	161077601	1	BOCCOLA 13X8,5X15	BUSH 13X8.5X15	DOUILLE 13X8,5X15	BUCHSE 13X8,5X15	BUJE 13X8,5X15
	3	800085380	1	CUSCINETTO A SFERE 85X45X19	BEARING, BALL 85X45X19	ROULEMENT A BILLES 85X45X19	KUGELLAGER 85X45X19	COJINETE DE BOLAS 85X45X19
	4	800085381	1	PARAOLIO 60X45X7	OIL SEAL 60X45X7	BAGUE D'ETANCHEITE 60X45X7	WELLENDICHRING 60X45X7	RETEN DE ACEITE 60X45X7
	5	800085383	1	PIASTRINA RITEGNO PARAOLIO	PLATE HOLDING OIL SEAL	PLAQUETTE FIXATION BAGUE ETANCHEITE	HALTEPLATTE WELLENDICHRING	PLACA SUJECION RETEN ACEITE
	6	ZA0067997	2	VITE TEF M5X0,8X16 CH8	SCREW TEF M5X0.8X16 CH8	VIS TEF M5X0,8X16 CH8	SCHRAUBE TEF M5X0,8X16 CH8	TORNILLO TEF M5X0,8X16 CH8
	7	800062200	1	ASTUCCIO A RULLI 24X30X7,5	BEARING, NEEDLE 24X30X7.5	ROULEMENT A AIGUILLES 24X30X7,5	NADELLAGER 24X30X7,5	COJINETE DE AGUJAS 24X30X7,5
	8	800019768	1	CUSCINETTO A SFERE 42X15X13	BEARING, BALL 42X15X13	ROULEMENT A BILLES 42X15X13	KUGELLAGER 42X15X13	COJINETE DE BOLAS 42X15X13
	9	ZA0066525	1	VITE TEF M5X0,8X16 CH8	SCREW TEF M5X0.8X16 CH8	VIS TEF M5X0,8X16 CH8	SCHRAUBE TEF M5X0,8X16 CH8	TORNILLO TEF M5X0,8X16 CH8
	10	800081663	1	PIASTRINA RITEGNO	RETAINING PLATE	PLAQUE RETENUE	HALTEBLECH	CHAPA RETENCION
	11	800072966	1	SCHERMO TENUTA 204 JV	SEAL, MECHANICAL NUP 204 JV	TENUE MECANIQUE NUP 204 JV	MECHANISCHE DICHTUNG NUP 204 JV	SELLO MECANICO NUP 204 JV
	12	800072964	1	CUSCINETTO A RULLI 20X47X14	ROLLERS BEARING 20X47X14	ROULEMENT A ROULEAUX 20X47X14	ROLLENLAGER 20X47X14	COJINETE DE RODILLOS 20X47X14
	13	800043789	1	CUSCINETTO A RULLI NU205	BEARING, ROLLER NU205	ROULEMENT A ROULEAUX NU205	ROLLENLAGER NU205	COJINETE RODILLOS NU205
	14	800059977	1	PARAOLIO 32X40X5	SEAL, OIL 32X40X5	BAGUE D'ETANCHEITE 32X40X5	WELLENDICHRING 32X40X5	RETEN DE ACEITE 32X40X5
	15	800060464	1	DISTANZIALE 32X28,2X25X10,3	SPACER 32X28.2X25X10.3	ENTRETOISE 32X28,2X25X10,3	ABSTANDHALTER 32X28,2X25X10,3	DISTANCIADOR 32X28,2X25X10,3
	16	800023110	1	ANELLO O-RING 2100 28,68X1,72	O-RING 2100 28.68X1.72	JOINT TORIQUE 2100 28,68X1,72	O-RING 2100 28,68X1,72	JUNTA TORICA 2100 28,68X1,72
	17	80A0H0994	1	FLANGIA SPINGIFRIZIONE IDRAULICO	FLANGE, CYLINDER CLUTCH PRESSURE	BRIDE CYLINDRE POUSSEE EMBRAYAGE	FLANSCH, KUPPLUNG SZYLINDERDRUCH	BRIDA CILINDRO EMPUJADOR EMBRAGUE
	18	Z00062730	2	VITE TEF M6X1X30	SCREW TEF M6X1X30	VIS TEF M6X1X30	SCHRAUBE TEF M6X1X30	TORNILLO TEF M6X1X30
	19	8B0023109	1	ANELLO O-RING	O-RING	JOINT TORIQUE	O-RING	JUNTA TORICA
	20	ZB0067545	9	VITE TEF M6X1X55 CH8	SCREW TEF M6X1X55 CH8	VIS TEF M6X1X55 CH8	SCHRAUBE TEF M6X1X55 CH8	TORNILLO TEF M6X1X55 CH8
	21	ZC0067545	2	VITE TEF M6X1X65 CH8	SCREW TEF M6X1X65 CH8	VIS TEF M6X1X65 CH8	SCHRAUBE TEF M6X1X65 CH8	TORNILLO TEF M6X1X65 CH8
	22	800007719	2	GRANO RIFERIMENTO 10X7,2X16	PIN, DOWEL 10X7.2X16	GOUJON DE REFERENCE 10X7,2X16	BEZUGSSTIFT 10X7,2X16	ESPIGA DE REFERENCIA 10X7,2X16
	23	161459002	1	BOCCOLA 22X17,5X15	BUSH 22X17.5X15	DOUILLE 22X17,5X15	BUCHSE 22X17,5X15	BUJE 22X17,5X15
	24	800071154	1	BOCCOLA FLANGIATA 32X22X17,2	BUSH WITH COLLAR 32X22X17.2	DOUILLE BRIDEE 32X22X17,2	GEFLANSCHBUCHSE 32X22X17,2	CASQUILLO REBORDEADO 32X22X17,2
	25	60ND02866	2	VITE TCI M4X0,7X6	SCREW TCI M4X0.7X6	VIS TCI M4X0,7X6	SCHRAUBE TCI M4X0,7X6	TORNILLO TCI M4X0,7X6
	26	161510501	1	FERMO PETALO LAMELLA	STOPPER, REED VALVE	PLAQUE ARRET CLAPET	STOPPLATTE LAMELLENVENTIL	PLACA RETENCION VALVULA LAMINAS
	27	161534801	1	VALVOLA LAMELLARE	READ VALVE COMP	SOUPAPE CLAPET	LAMELLENVENTIL	VALVULA LAMINAS
	28	66N021211	1	ANELLO SEEGER 25mm DIN471	CIRCLIP 25mm DIN471	CIRCLIP 25mm DIN471	SPRENGRING 25mm DIN471	ANILLO SEEGER 25mm DIN471
	29	M000P00712	1	PIGNONE Z15	SPROCKET, CHAIN T15	PIGNON CHAINE Z15	KETTENRITZEL Z15	PINON CADENA Z15
	30	800034451	1	PARAOLIO 12X19X5	OIL SEAL 12X19X5	BAGUE D'ETANCHEITE 12X19X5	WELLENDICHRING 12X19X5	RETEN DE ACEITE 12X19X5
	31	8A0065847	1	BOCCOLA	BUSH	DOUILLE	BUCHSE	BUJE
	32	161077701	1	BOCCOLA FLANGIATA	BUSH WITH COLLAR	DOUILLE BRIDEE	GEFLANSCHBUCHSE	CASQUILLO REBORDEADO
	33	161077702	2	BOCCOLA FLANGIATA 20X12,8X8	BUSH WITH COLLAR 20X12.8X8	DOUILLE BRIDEE 20X12,8X8	GEFLANSCHBUCHSE 20X12,8X8	CASQUILLO REBORDEADO 20X12,8X8

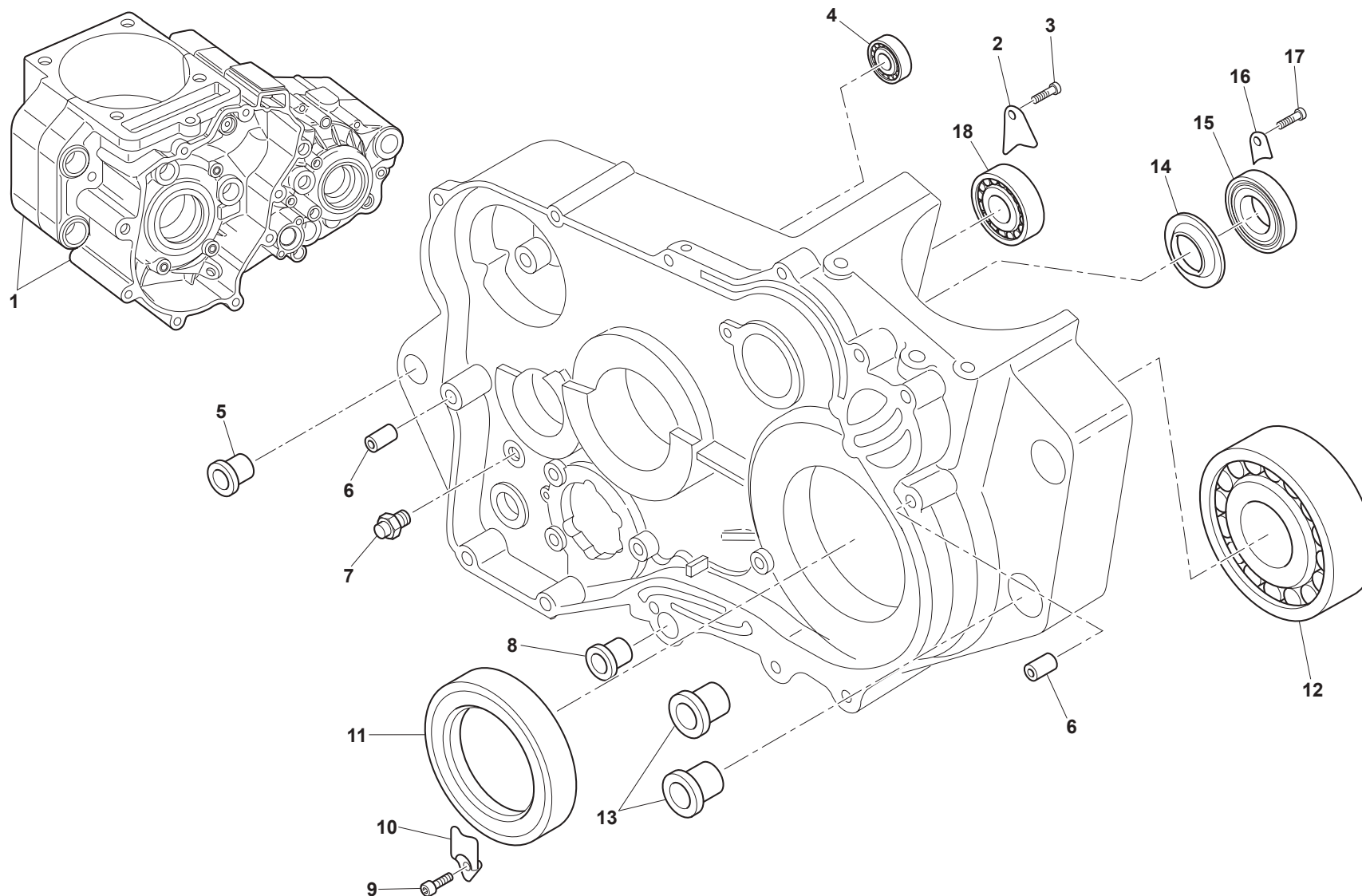





Superdual 2017

**SEMICARTER DESTRO - R.H. HALF CRANKCASE**  
**CARTER D. - GEHAUSEDECKEL R.**  
**BANCADA DER.**

TAVOLA  
DRAWING  
TABLE  
BILD  
TABLA

8

Note Notes Marke Notas	Pos. No. N. Index Pos.	N. Cod. Code No. Nr. Code Code Nr N. Cod.	Q.tà Q.ty Q.te M.ge C.ad	DENOMINAZIONE	NAME	DESIGNATION	BESHREIBUNG	DENOMINACION
	1	M000A00102	1	CARTER MOTORE	CRANKCASE SET	CARTER MOTEUR	KURBELWELLENGEHAUSE	CARTER MOTOR
	2	800051746	1	PIASTRINA RITEGNO CUSCINETTO	RETAINER, BEARING	PLAQUE ARRET ROULEMENT	STOPPLATTE, LAGER	PLACA RETENCION COJINETE
	3	Z00042643	1	VITE SVASATA M6X1,00X8,5	SCREW M6X1.00X8.5	VIS M6X1,00X8,5	SCHRAUBE M6X1,00X8,5	TORNILLO M6X1,00X8,5
	4	800072962	1	CUSCINETTO A SFERE 47X17X14	BEARING, BALL 47X17X14	ROULEMENT A BILLES 47X17X14	KUGELLAGER 47X17X14	COJINETE DE BOLAS 47X17X14
OPT	4	800010290	1	CUSCINETTO A SFERE 47X17X14	BEARING, BALL 47X17X14	ROULEMENT A BILLES 47X17X14	KUGELLAGER 47X17X14	COJINETE DE BOLAS 47X17X14
	5	800071154	1	BOCCOLA FLANGIATA 32X22X17,2	BUSH WITH COLLAR 32X22X17.2	DOUILLE BRIDEE 32X22X17,2	GEFLANSCHBUCHSE 32X22X17,2	CASQUILLO REBORDEADO 32X22X17,2
	6	800007719	2	GRANO RIFERIMENTO 10X7,2X16	PIN, DOWEL 10X7.2X16	GOUJON DE REFERENCE 10X7,2X16	BEZUGSSTIFT 10X7,2X16	ESPIGA DE REFERENCIA 10X7,2X16
	7	8A0066953	1	PERNO	PIN	PIVOT	BOLZEN	PERNO
	8	161077701	1	BOCCOLA FLANGIATA	BUSH WITH COLLAR	DOUILLE BRIDEE	GEFLANSCHBUCHSE	CASQUILLO REBORDEADO
	9	Z00062725	1	VITE TEF M6X1X10 CH8	SCREW TEF M6X1.00X10 CH8	VIS TEF M6X1,00X10 CH8	SCHRAUBE TEF M6X1,00X10 CH8	TORNILLO TEF M6X1,00X10 CH8
	10	800085382	1	PIASTRINA RITEGNO PARAOLIO	PLATE HOLDING OIL SEAL	PLAQUETTE FIXATION BAGUE ETANCHEITE	HALTEPLATTE WELLENDICHRING	PLACA SUJECION RETEN ACEITE
	11	800085381	1	PARAOLIO 60X45X7	OIL SEAL 60X45X7	BAGUE D'ETANCHEITE 60X45X7	WELLENDICHRING 60X45X7	RETEN DE ACEITE 60X45X7
	12	800085380	1	CUSCINETTO A SFERE 85X45X19	BEARING, BALL 85X45X19	ROULEMENT A BILLES 85X45X19	KUGELLAGER 85X45X19	COJINETE DE BOLAS 85X45X19
	13	161077702	2	BOCCOLA FLANGIATA 20X12,8X8	BUSH WITH COLLAR 20X12.8X8	DOUILLE BRIDEE 20X12,8X8	GEFLANSCHBUCHSE 20X12,8X8	CASQUILLO REBORDEADO 20X12,8X8
	14	8B0072966	1	SCHERMO TENUTA 6204 Z JV	SEAL, MECHANICAL 6204 Z JV	TENUE MECANIQUE 6204 Z JV	MECHANISCHE DICHTUNG 6204 Z JV	SELLO MECANICO 6204 Z JV
	15	800076680	1	CUSCINETTO A SFERE 20X47X14	BEARING, BALL 20X47X14	ROULEMENT A BILLES 20X47X14	KUGELLAGER 20X47X14	COJINETE DE BOLAS 20X47X14
	16	800081663	1	PIASTRINA RITEGNO	RETAINING PLATE	PLAQUE RETENUE	HALTEBLECH	CHAPA RETENCION
	17	ZA0066525	1	VITE TEF M5X0,8X16 CH8	SCREW TEF M5X0.8X16 CH8	VIS TEF M5X0,8X16 CH8	SCHRAUBE TEF M5X0,8X16 CH8	TORNILLO TEF M5X0,8X16 CH8
	18	8A0059975	1	CUSCINETTO A SFERE 52X25X15	BEARING, BALL 52X25X15	ROULEMENT A BILLES 52X25X15	KUGELLAGER 52X25X15	COJINETE DE BOLAS 52X25X15

SENSO DI MARCIA  
DIRECTION OF TRAVEL  
DIRECTION DE VOYAGE  
FAHRTRICHTUNG  
DIRECCIÓN DE VIAJE

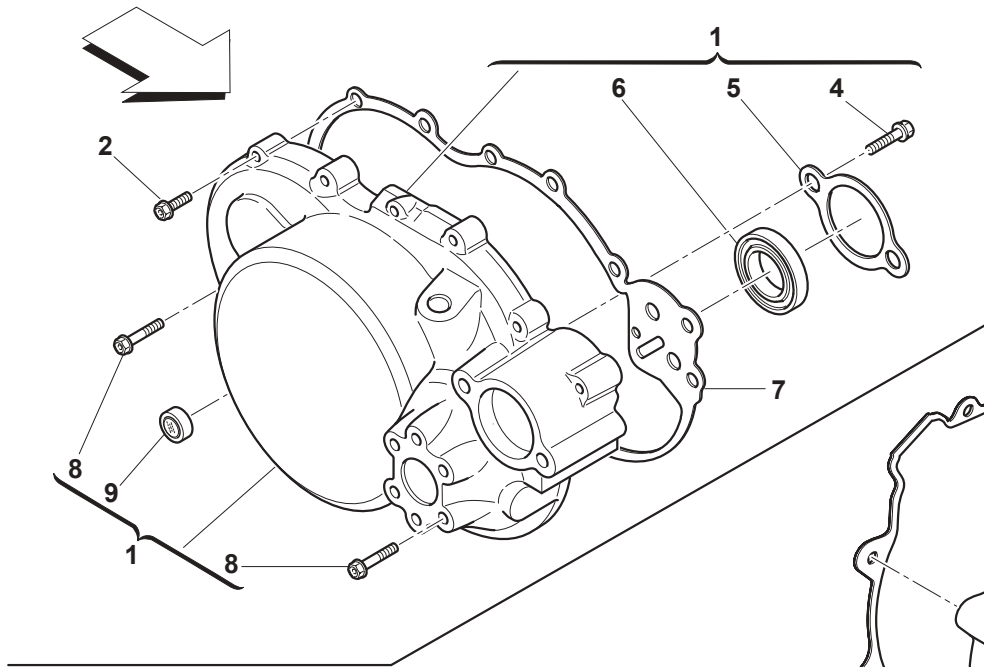

SENSO DI MARCIA  
DIRECTION OF TRAVEL  
DIRECTION DE VOYAGE  
FAHRTRICHTUNG  
DIRECCIÓN DE VIAJE

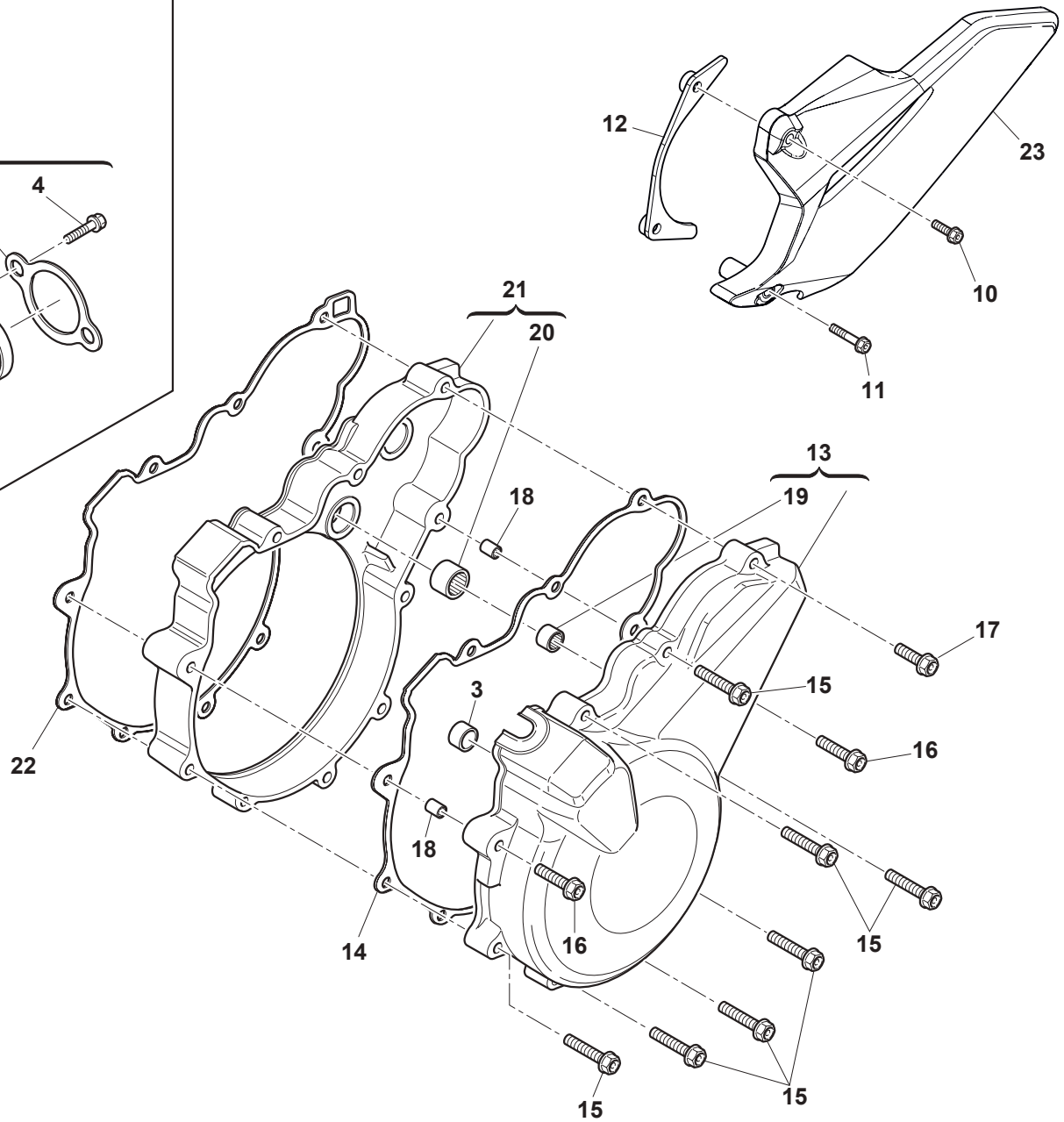



Superdual 2017

COPERCHI BASAMENTO - CRANKCASE COVERS  
COUVERCLES CARTER - GEHAUSEDECKEL  
TAPAS BANCADA

TAVOLA  
DRAWING  
TABLE  
BILD  
TABLA

9

Note Notes Marke Notas	Pos. No. Index Pos.	N. Cod. Code No. Nr. Code Code Nr N. Cod.	Q.tà Q.ty Q.te M.ge C.ad	DENOMINAZIONE	NAME	DESIGNATION	BESHREIBUNG	DENOMINACION
	1	M000A00106	1	COPERCHIO FRIZIONE	COVER, CLUTCH	COUVERCLE EMBRAYAGE	KUPPLUNGSDECKEL	CUBIERTA EMBRAGUE
	2	Z00062730	11	VITE TEF M6X1X40	SCREW TEF M6X1X40	VIS TEF M6X1X40	SCHRAUBE TEF M6X1X40	TORNILLO TEF M6X1X40
	3	800002124	1	CUSCINETTO A SFERE 6201C3 32X12X10	BALL BEARING 6201C3 32X12X10	ROULEMENT A BILLES 6201C3 32X12X10	KUGELLAGER 6201C3 32X12X10	COJINETE DE BOLAS 6201C3 32X12X10
	4	Z00049608	2	VITE TSEI M5X0,8X10	SCREW TSEI M5X0,8X10	VIS TSEI M5X0,8X10	SCHRAUBE TSEI M5X0,8X10	TORNILLO TSEI M5X0,8X10
	5	800084817	1	FLANGIA PARAOLIO	COVER, OIL SEAL	PLAQUE ARRET	STOPPLATTE	PLACA RETENCION
	6	800062209	1	PARAOLIO 17X28X7	OIL SEAL 17X28X7	BAGUE D'ETANCHEITE 17X28X7	WELLENDICHRING 17X28X7	RETEN DE ACEITE 17X28X7
	7	M000P00108	1	GUARNIZIONE COPERCHIO FRIZIONE	GASKET, CLUTCH COVER	JOINT COUVERCLE EMBRAYAGE	DICHTUNG KUPPLUNGSDECKEL	JUNTA CUBIERTA EMBRAGUE
	8	ZC0067545	2	VITE TEF M6X1X65 CH8	SCREW TEF M6X1X65 CH8	VIS TEF M6X1X65 CH8	SCHRAUBE TEF M6X1X65 CH8	TORNILLO TEF M6X1X65 CH8
	9	800073529	1	VETRINO SPIA LIVELLO OLIO	WINDOW, OIL LEVEL CHECK	HUBLOT NIVEAU HUILE	SCHAUGLAS, OELKONTROLL	MIRILLA NIVEL ACEITE
	10	Z00067545	1	VITE TEF M6X1X25 CH8	SCREW TEF M6X1X25 CH8	VIS TEF M6X1X25 CH8	SCHRAUBE TEF M6X1X25 CH8	TORNILLO TEF M6X1X25 CH8
	11	ZA0067545	1	VITE TEF M6X1X45	SCREW TEF M6X1X45	VIS TEF M6X1X45	SCHRAUBE TEF M6X1X45	TORNILLO TEF M6X1X45
	12	8000H2207	1	PIASTRINA	PLATE	PLAQUETTE	PLAETTCHEN	PLETINA
	13	M000A00105	1	COPERCHIO GENERATORE	COVER, GENERATOR	COUVERCLE GENERATEUR	DECKEL, STROMGENERATORS	CUBIERTA GENERADOR
	14	8000A1368	1	GUARNIZIONE COPERCHIO GENERATORE	GASKET, GENERATOR COVER	JOINT COUVERCLE GENERATEUR	DICHTUNG, STROMGENERATOR DECKEL	JUNTA CUBIERTA GENERADOR
	15	ZB0067545	7	VITE TEF M6X1X55 CH8	SCREW TEF M6X1X55 CH8	VIS TEF M6X1X55 CH8	SCHRAUBE TEF M6X1X55 CH8	TORNILLO TEF M6X1X55 CH8
	16	ZC0067545	2	VITE TEF M6X1X65 CH8	SCREW TEF M6X1X65 CH8	VIS TEF M6X1X65 CH8	SCHRAUBE TEF M6X1X65 CH8	TORNILLO TEF M6X1X65 CH8
	17	Z00062730	1	VITE TE M6X1X30 CH8	SCREW TE M6X1X30 CH8	VIS TE M6X1X30 CH8	SCHRAUBE TE M6X1X30 CH8	TORNILLO TE M6X1X30 CH8
	18	M000P00423	2	GRANO RIFERIMENTO 10X7,2	PIN, DOWEL 10X7,2	GOIJON DE REFERENCE 10X7,2	BEZUGSSTIFT 10X7,2	ESPIGA DE REFERENCIA 10X7,2
	19	800086243	1	ASTUCCIO A RULLI HK1015	BEARING, NEEDLE HK1015	ROULEMENT A AIGUILLES HK1015	NADELLAGER HK1015	COJINETE DE AGUJAS HK1015
	20	800033422	1	ASTUCCIO A RULLI HK1412	BEARING, NEEDLE HK1412	ROULEMENT A AIGUILLES HK1412	NADELLAGER HK1412	COJINETE DE AGUJAS HK1412
	21	8C0086246	1	SUPPORTO MOTORINO AVVIAMENTO	BRACKET STARTING MOTOR	SUPPORT, DEMARREUR ELECTRIQUE	HALTER, ANLASSERMOTOR	SOPORTE MOTOR ARRANQUE
	22	8000A1367	1	GUARNIZIONE FLANGIA MOTORINO AVVIAMENTO	GASKET	JOINT	DICHTUNG	JUNTA
	23	F000P00067	1	COPERCHIO PIGNONE	COVER, SPROCKET	COUVERCLE PIGNON CHAINE	DECKEL, RITZEL	CUBIERTA PINON CADENA

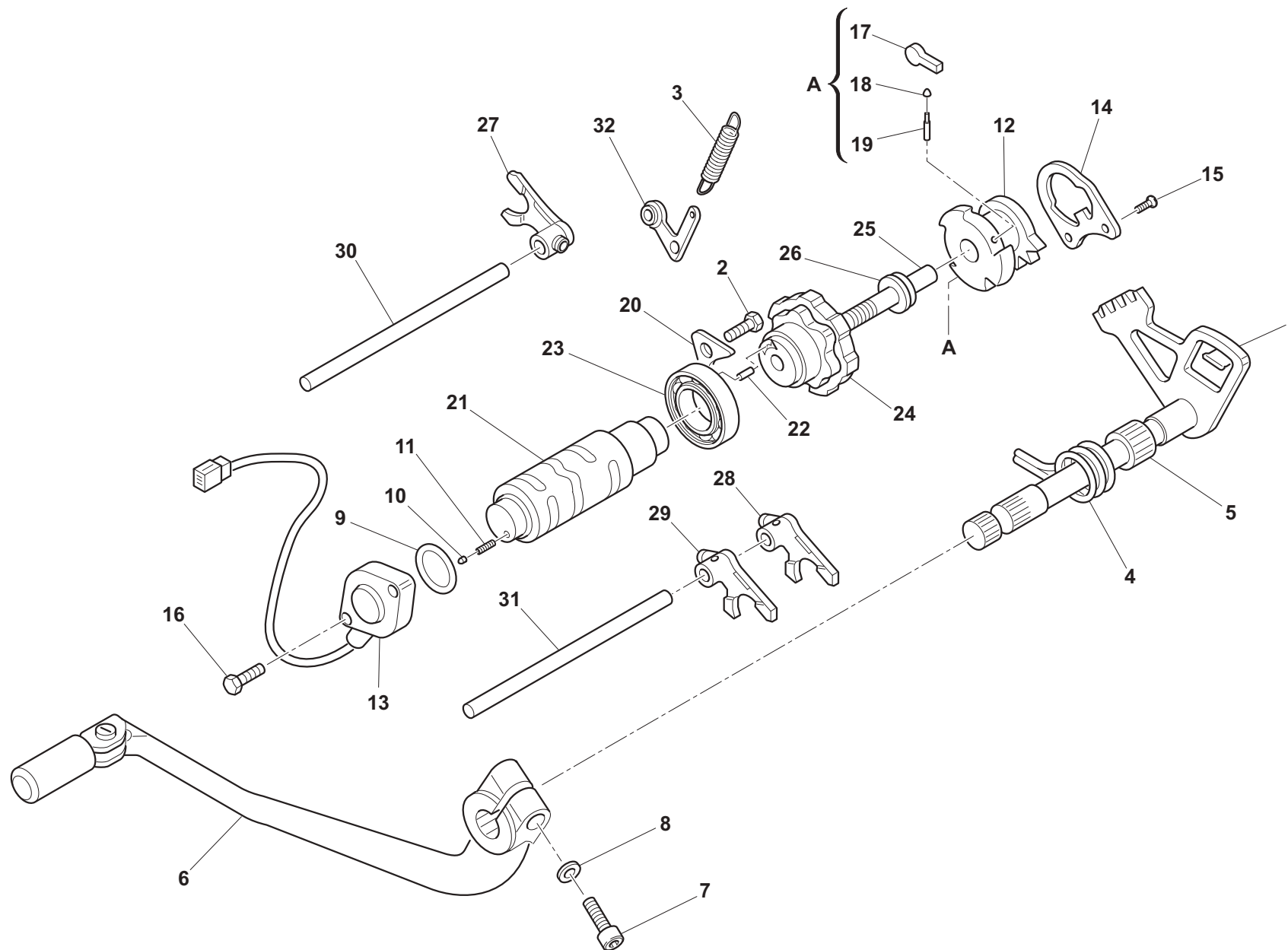

**Superdual 2017**

**COMANDO CAMBIO - GEARSHIFT MECHANISM  
 COMMANDE DE VITESSE - GANGSCHALTUNG  
 MANDO CAMBIO**

TAVOLA  
 DRAWING  
 TABLE  
 BILD  
 TABLA

**10**

Note Notes Marke Notas	Pos. No. Index Pos.	N. Cod. Code No. Nr. Code Code Nr N. Cod.	Q.tà Q.ty M.ge C.ad	DENOMINAZIONE	NAME	DESIGNATION	BESHREIBUNG	DENOMINACION
	1	800075302	1	ALBERO SELETTORE CAMBIO	GEAR SELECTOR SHAFT	ARBRE SELECTEUR DE VITESSES	SCHALTWELLE	ARBOL SELECTOR CAMBIO
	2	8B0054139	1	VITE TE M6X1X15	SCREW TE M6X1X15	VIS TE M6X1X15	SCHRAUBE TE M6X1X15	TORNILLO TE M6X1X15
	3	M000P00578	1	MOLLA SALTARELLO FISSA MARCIA	SPRING, PAWL	RESSORT CLIQUET	FEDER, STRUMHAKEN	MUELLE SALTARELO
	4	800046225	1	MOLLA CAMBIO	SPRING, SHIFT RETURN	RESSORT RAPPEL LEVIER COMMANDE	RUECKHOLFEDER SCHALTHEBEL	MUELLE RETRACTOR PALANCA CAMBIO
	5	8A0031503	1	BOCCOLA	BUSH	DOUILLE	BUCHSE	BUJE
	6	800081681	1	PEDALE CAMBIO	PEDAL, GEAR CHANGE	PEDALE CHANGEMENT VITESSE	SCHALTPEDAL	PEDAL, CAMBIO VELOCIDADES
	7	60ND07336	1	VITE TE M6X1X22	SCREW TE M6X1X22	VIS TE M6X1X22	SCHRAUBE TE M6X1X22	TORNILLO TE M6X1X22
	8	62NA15767	1	RONDELLA ELASTICA	WASHER, SPRING	RONDELLE ELASTIQUE	FEDERSCHEIBE	ARANDELA ELASTICA
	9	8A0042700	1	ANELLO O-RING 2093 23,52X1,78 mm	O-RING 2093 23.52X1.78 mm	JOINT TORIQUE 2093 23,52X1,78 mm	O-RING 2093 23,52X1,78 mm	JUNTA TORICA 2093 23,52X1,78 mm
	10	800042676	1	PUNTALE FOLLE	POINT, NEUTRAL	CONTACTEUR POINT-MORT	BOLZEN LEERLAUF	PUNTO NEUTRO
	11	800042677	1	MOLLA PUNTALE	SPRING	RESSORT	FEDER	MUELLE
	12	800075291	1	ROCCHETTO DESMODROMICO	CAM-CHANGE DRUM	PIGNION DESMODROMIQUE	VERSCHIEBENOCKENRITZEL	PINION TAMBOR CAMBIO
	13	8000A6751	1	SEGNALETORE MARCE	SENSOR ASSY, GEAR POSITION	CAPTEUR POINT MORT	SENSOR LEERLAUF	SENSOR PUNTO MUERTO
	14	800071012	1	PIASTRINA	PLATE	PLAQUETTE	PLAETTCHEN	PLETINA
	15	Y00028327	2	VITE TSEI M6X1X14 CH4	SCREW TSEI M6X1X14 CH4	VIS TSEI M6X1X14 CH4	SCHRAUBE TSEI M6X1X14 CH4	TORNILLO TSEI M6X1X14 CH4
	16	Z00067997	2	VITE TEF M5X0,8X12 CH8	SCREW TEF M5X0.8X12 CH8	VIS TEF M5X0,8X12 CH8	SCHRAUBE TEF M5X0,8X12 CH8	TORNILLO TEF M5X0,8X12 CH8
	17	800071007	2	SALTARELLO ROCCHETTO	PAWL	CLIQUET	STRUMHAKEN	SALTARELO
	18	800071008	2	PUNTALE SALTARELLO	PUSH ROD	BARRE PRESSION	DRUCKSTANGE	VARILLA PRESION
	19	800071009	2	MOLLA PUNTALE	SPRING	RESSORT	FEDER	MUELLE
	20	800083126	1	PIASTRINA RITEGNO CUSCINETTO	RETAINER, BEARING	PLAQUE ARRET ROULEMENT	STOPPLATTE, LAGER	PLACA RETENCION COJINETE
	21	800082347	1	TAMBURO DESMODROMICO	CAM, GEAR SHIFT	TAMBOUR DESMODROMIQUE	VERSCHIEBENOCKEN	TAMBOR CAMBIO
	22	800038520	1	RULLO 4X8	ROLLER 4X8	ROULEAU 4X8	ROLLE 4X8	RODILLO 4X8
	23	800085395	1	CUSCINETTO A SFERE 25X42X9	BEARING, BALL 25X42X9	ROULEMENT A BILLES 25X42X9	KUGELLAGER 25X42X9	COJINETE DE BOLAS 25X42X9
	24	8A0097739	1	ROCCHETTO DESMODROMICO	CAM-CHANGE DRUM	PIGNION DESMODROMIQUE	VERSCHIEBENOCKENRITZEL	PINION TAMBOR CAMBIO
	25	800071011	1	VITE	SCREW	VIS	SCHRAUBE	TORNILLO
	26	Z00056377	1	RONDELLA 16X8,3X1	WASHER 16X8.3X1	RONDELLE 16X8,3X1	SCHEIBE 16X8,3X1	ARANDELA 16X8,3X1
	27	800071158	1	FORCHETTA SELETTORE CAMBIO 3A-4A	FORK, GEAR SHIFTING 3TH-4TH	FOURCHETTE SELECTEUR 3EME-4EME	SCHALTGABEL 3.-4. GANG	HORQUILLA SELECTOR 3ERA-4A
	28	800071159	1	FORCHETTA SELETTORE CAMBIO 1A-5A	FORK, GEAR SHIFTING 1ST-5TH	FOURCHETTE SELECTEUR 1ERE-5EME	SCHALTGABEL 1.-5. GANG	HORQUILLA SELECTOR 1ERA-5A
	29	800071160	1	FORCHETTA SELETTORE CAMBIO 2A-6A	FORK, GEAR SHIFTING 2ND-6TH	FOURCHE ENGRENEMENT 2EME-6EME	SCHALTGABEL 2.-6.	HORQUILLA SELECTOR 2NDA-6A
	30	800035876	1	ASSE FORCHETTA SELETTORE CAMBIO 85mm	AXLE, GEAR SHIFT FORK 85 mm	AXE FOURCHETTE CHANGEMENT 85 mm	ACHSE, SCHALTGABEL 85 mm	EJE, HORQUILLA CAMBIO 85 mm
	31	8B0035876	1	ASSE FORCHETTA SELETTORE CAMBIO 93,5mm	AXLE, GEAR SHIFT FORK 93.5 mm	AXE FOURCHETTE CHANGEMENT 93,5 mm	ACHSE, SCHALTGABEL 93,5 mm	EJE, HORQUILLA CAMBIO 93,5 mm
	32	800054136	1	SALTARELLO FISSA MARCE	STOPPER LEVER	CLIQUET COMPLETE	SPERRKLINKE	TRINQUETE FIJO MARCHAS

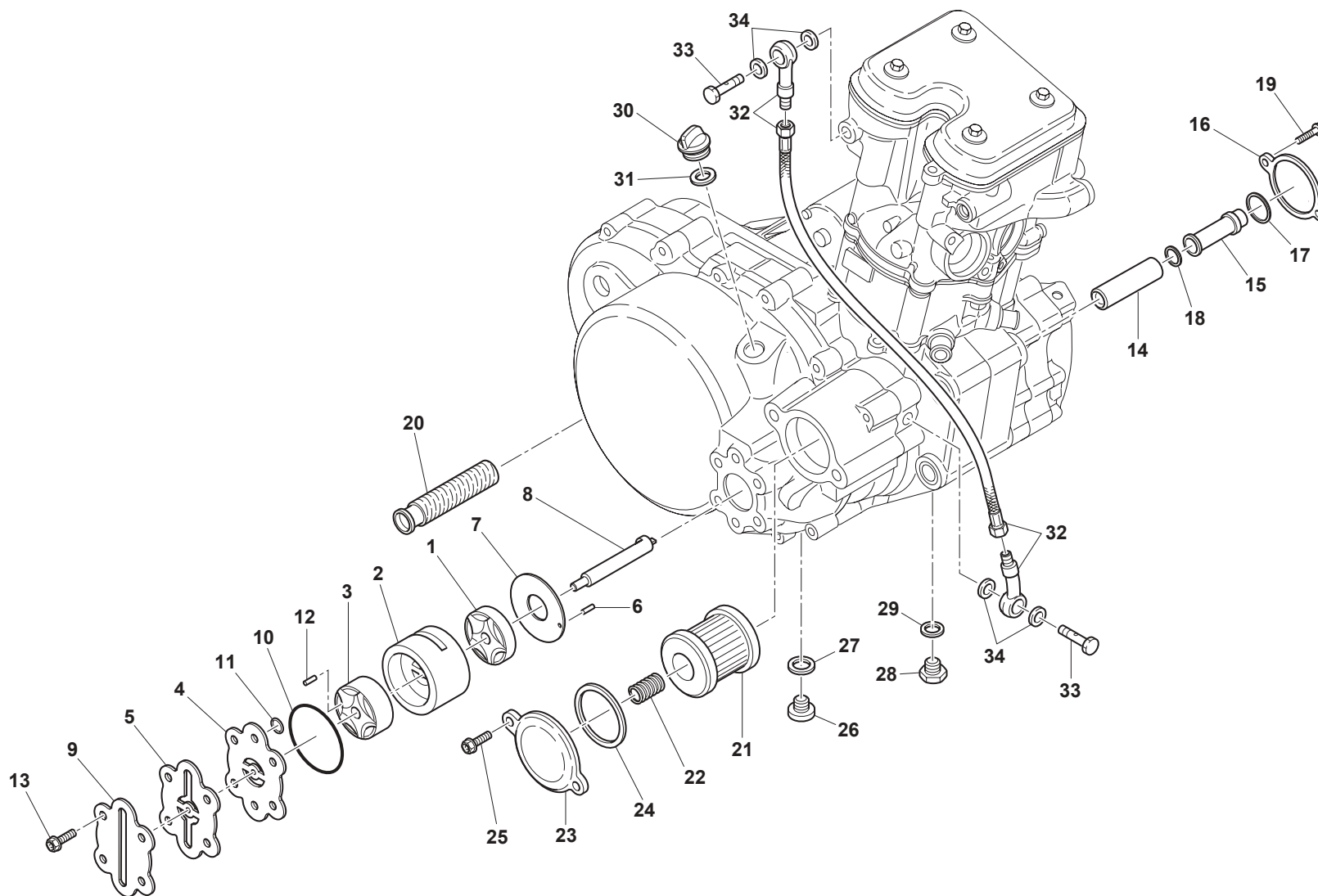



## LUBRIFICAZIONE - LUBRIFICATION GRAISSAGE - SCHMIERUNG LUBRICACION

Note Notes Notes Marke Notas	Pos. No. N. Index Pos.	N. Cod. Code No. Nr. Code Code Nr N. Cod.	Q.tà Q.ty Q.te M.ge C.ad	DENOMINAZIONE	NAME	DESIGNATION	BESHREIBUNG	DENOMINACION
	1	8000H4001	1	ROTORE RITORNO POMPA OLIO	ROTOR, OIL PUMP SCAVENGE	ROTOR RETOUR POMPE A HUILE	ROTOR, OELPUMPE RUECKLAUF	ROTOR RETORNO BOMBA ACEITE
	2	8000H4002	1	CORPO POMPA OLIO	HOUSING, OIL PUMP	CORPS POMPE A HUILE	OELPUMPEGEHAEUSE	CUERPO BOMBA ACEITE
	3	800082948	1	TROCOIDE ASPIRAZIONE OLIO	OIL SUCTION ROTOR	ROTOR ASPIRATEUR HUILE	OELSAUGROTOR	ROTOR ADMISION ACEITE
	4	800084821	1	COPERCHIO INTERMEDIO POMPA	COVER	COUVERCLE	DECKEL	TAPA
	5	8000A1374	1	FLANGIA CUSCINETTO	HOUSING, BEARING	BOITE PORTE ROULEMENT	GEHAUSE, LAGERHALTERUNG	CAJA SOPORTE COJNETE
	6	8B0047773	1	RULLINO DI RIFERIMENTO	ROLLER	ROULEAU	ROLLE	RODILLO
	7	800084819	1	DISTANZIALE INTERNO POMPA	INNER SPACER	ENTRETOISE INTERIEUR	INNEREABSTANDHALTER	DISTANCIADOR INTERIOR
	8	800084818	1	ALBERO POMPA OLIO	SHAFT, OIL PUMP	ARBRE POMPE A HUILE	WELLE, OELPUMPE	ARBOL, BOMBA ACEITE
	9	80C075630	1	COPERCHIO POMPA OLIO	COVER OIL PUMP	COUVERCLE POMPE HUILE	OELPUMPENDECKEL	CUBIERTA BOMBA ACEITE
	10	800027073	1	ANELLO O-RING 3156 39,34X2,6	O-RING 3156 39,34X2,6	JOINT TORIQUE 3156 39,34X2,6	O-RING 3156 39,34X2,6	JUNTA TORICA 3156 39,34X2,6
	11	8A0023108	2	ANELLO O-RING 2037 1,78X9,25	O RING 2037 1.78X9.25	JOINT TORIQUE 2037 1,78X9,25	O-RING 2037 1,78X9,25	JUNTA TORICA 2037 1,78X9,25
	12	8A0047773	2	RULLINO	ROLLER	ROULEAU	ROLLE	RODILLO
	13	Z00062728	4	VITE TEF M6X1X20 CH8	SCREW TEF M6X1X20 CH8	VIS TEF M6X1X20 CH8	SCHRAUBE TEF M6X1X20 CH8	TORNILLO TEF M6X1X20 CH8
	14	800072426	1	FILTRO OLIO ESTERNO	OIL FILTER, OUTER	FILTRE A HUILE EXTERIEUR	OELFILTER, AUSSER	FILTRO ACEITE EXTERIOR
	15	800072427	1	FILTRO OLIO INTERNO	OIL FILTER, INNER	FILTRE A HUILE INTERIEUR	OELFILTER, INNEN	FILTRO ACEITE INTERIOR
	16	800072425	1	COPERCHIO FILTRO OLIO	COVER, OIL ELEMENT	COUVERCLE FILTRE A HUILE	DECKEL, OELFILTER	CUBIERTA FILTRO ACEITE
	17	800034609	1	ANELLO O-RING 3087 22X2,62	O-RING 3087 22X2.62	JOINT TORIQUE 3087 22X2,62	O-RING 3087 22X2,62	JUNTA TORICA 3087 22X2,62
	18	800026884	1	ANELLO O-RING 3062 15,54X2,62	O-RING 3062 15.54X2.62	JOINT TORIQUE 3062 15,54X2,62	O-RING 3062 15,54X2,62	JUNTA TORICA 3062 15,54X2,62
	19	Z00067997	2	VITE TEF M5X0,8X12 CH8	SCREW TEF M5X0,8X12 CH8	VIS TEF M5X0,8X12 CH8	SCHRAUBE TEF M5X0,8X12 CH8	TORNILLO TEF M5X0,8X12 CH8
	20	800074716	1	FILTRO OLIO ASPIRAZIONE	STRAINER, OIL	CREPINE HUILE	OELNETZ	REDECILLA ACEITE
	21	8000B0593	1	FILTRO OLIO	FILTER, OIL	FILTRE A HUILE	OELFILTER	FILTRO ACEITE
	22	800085385	1	MOLLA FILTRO OLIO	SPRING, OIL FILTER	RESSORT FILTRE A HUILE	FEDER, OELFILTER	RESORTE, FILTRO ACEITE
	23	80C078988	1	COPERCHIO FILTRO OLIO	COVER, OIL ELEMENT	COUVERCLE FILTRE A HUILE	DECKEL, OELFILTER	CUBIERTA FILTRO ACEITE
	24	8A0028553	1	ANELLO O-RING 3200 2,62X50,47	O-RING 3200	JOINT TORIQUE 3200	O-RING 3200	JUNTA TORICA 3200
	25	Z00062728	2	VITE TEF M6X1X20 CH8	SCREW TEF M6X1X20 CH8	VIS TEF M6X1X20 CH8	SCHRAUBE TEF M6X1X20 CH8	TORNILLO TEF M6X1X20 CH8
	26	800096747	1	TAPPO DRENAGGIO OLIO M22X1,5	OIL DRAIN PLUG M22X1.5	BOUCHON VIDANGE HUILE M22X1,5	OELABLASSVERSCHLUSS M22X1,5	TAPON PURGA ACEITE M22X1,5
	27	62N015682	1	RONDELLA GUARNIZIONE 22,3X28X1	WASHER 22.3X28X1	RONDELLE 22,3X28X1	SCHEIBE 22,3X28X1	ARANDELA 22,3X28X1
	28	800075415	1	TAPPO DRENAGGIO OLIO M14X1,25	OIL DRAIN PLUG M14X1,25	BOUCHON VIDANGE HUILE M14X1,25	OELABLASSVERSCHLUSS M14X1,25	TAPON PURGA ACEITE M14X1,25
	29	62N015678	1	RONDELLA IN ALLUMINIO 21X14,3X1,2	WASHER, ALUMINIUM 21X14.3X1.2	RONDELLE EN ALUMINIUM 21X14,3X1,2	ALUMINIUM SCHEIBE 21X14,3X1,2	ARANDELA ALUMINIO 21X14,3X1,2
	30	800049032	1	TAPPO ALIMENTAZIONE OLIO	CAP, OIL FILLER	BOUCHON REMPLISSEMENT HUILE	STOEPSSEL OELEINFUELL	TAPON INTRUDUCCION ACEITE
	31	800019789	1	ANELLO O-RING 2081 20,35X1,78	O-RING 2081 20.35X1.78	JOINT TORIQUE 2081 20,35X1,78	O-RING 2081 20,35X1,78	JUNTA TORICA 2081 20,35X1,78
	32	8000H1763	1	TUBO MANDATA OLIO	HOSE, OIL DELIVERY	TUYAU REFOULEMENT HUILE	OELZUFUHRLEITUNG	TUBO ALIMENTACION ACEITE
	33	8A00A0574	2	VITE FORATA	BANJO BOLT	VIS CREUSE	HOHLSCHRAUBE	TORNILLO TALADRADO

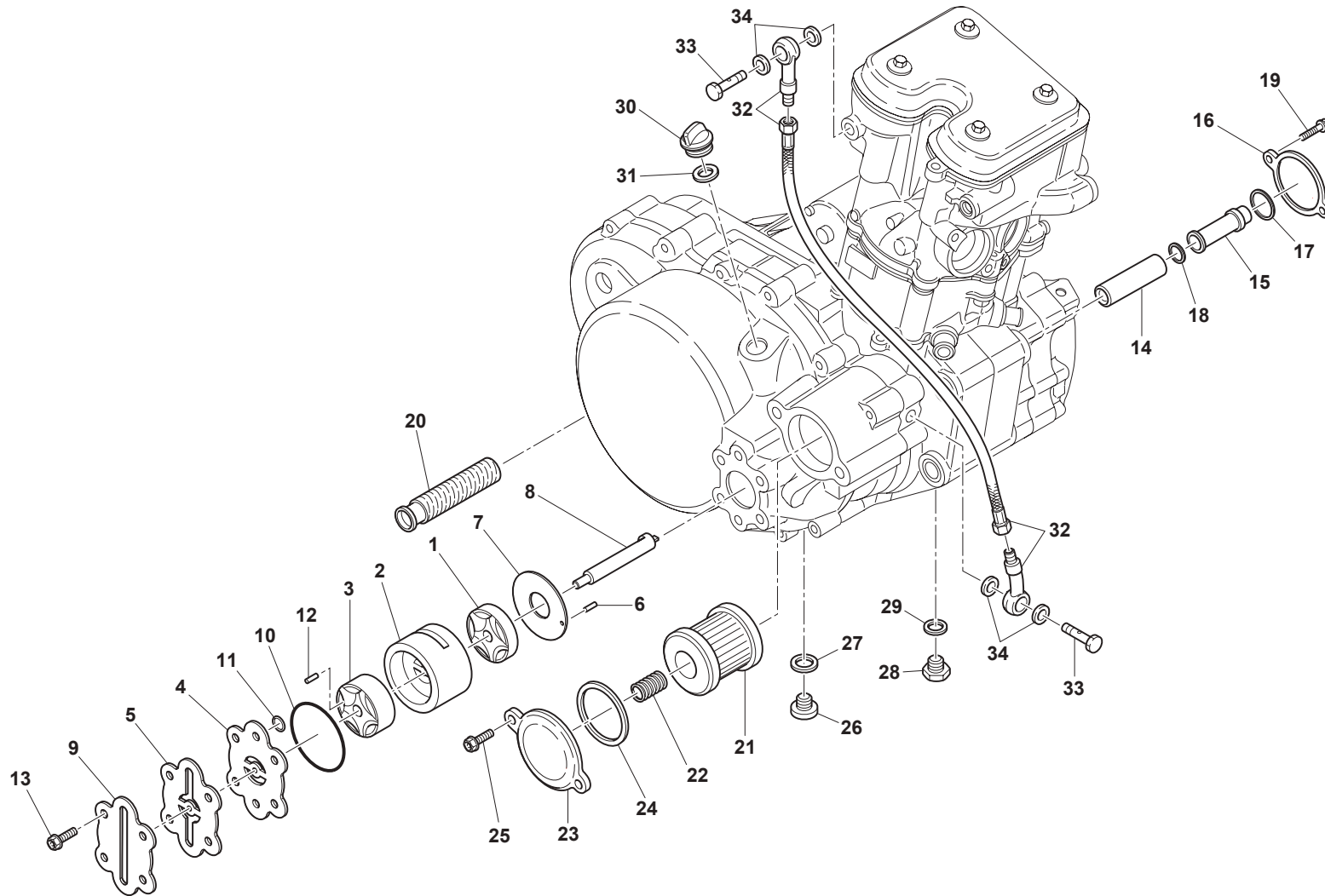





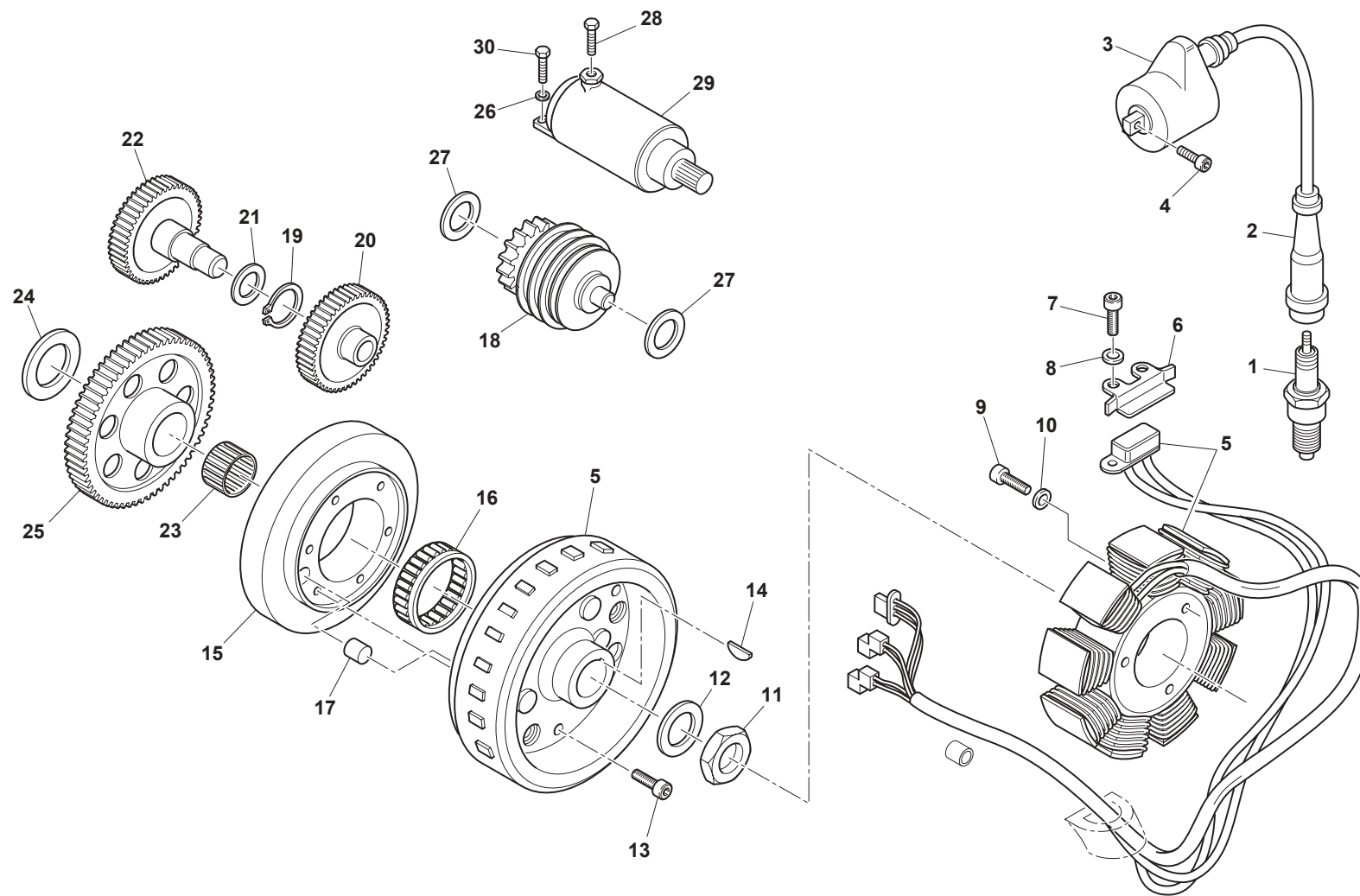



**PARTE ELETTRICA, IMPIANTO ELETTRICO - IGNITION SYSTEM, ELECTRIC SYSTEM  
PARTIES ELECTRIQUE, INSTALLATION ELECTRIQUE- ELEKTRISCHE TEILE, ELEKTRISCHE ANLAGE  
PARTE ELECTRICA, INSTALACION ELECTRICA**

Note Notes Notas	Pos. No. Index Pos.	N. Cod. Code No. Nr. Code Code Nr N. Cod.	Q.tà Q.ty M.ge C.ad	DENOMINAZIONE	NAME	DESIGNATION	BESHREIBUNG	DENOMINACION
	1	8000A0573	1	CANDELA	PLUG, SPARK	BOUGIE	ZUENDKERZE	BUJIA
	2	8000A6740	1	PIPETTA CANDELA	CAP, SPARK PLUG	ANTIPARASITE	ZUENDKERZENSTECKER	CAPUCHON PORTA BUJIA
	3	8000H0277	1	BOBINA ACCENSIONE	COIL, IGNITION	BOBINE ALLUMAGE	ZUENDSPULE	BOBINA ENCENDIDO
	4	Z00062728	2	VITE TEF M6X1X20 CH8	SCREW TEF M6X1X20 CH8	VIS TEF M6X1X20 CH8	SCHRAUBE TEF M6X1X20 CH8	TORNILLO TEF M6X1X20 CH8
	5	M000A00914	1	ASSIEME GENERATORE CON RUOTA LIBERA	ASSY GENERATOR WITH FREEWHEEL	GENERATEUR COMPL. AVEC ROUE LIBRE	ZUSAMMENBAU STROMGENERATOR MIT FREILAUF	CONJUNTO GENERADOR CON RUEDA LIBRE
	6	8000H3841	1	FERMACAVO	CLAMP, WIRE	COLLIER, CORDON	KABELKLEMME	GRAMPA CORDON
	7	60ND02461	2	VITE TCEI M4X0,7X10	SCREW TCEI M4X0,7X10	VIS TCEI M4X0,7X10	SCHRAUBE TCEI M4X0,7X10	TORNILLO TCEI M4X0,7X10
	8	62ND15534	2	RONDELLA ELASTICA 7,3X4,3X0,9	SPRING WASHER 7.3X4.3X0.9	RONDELLE ELASTIQUE 7,3X4,3X0,9	FEDERSCHEIBE 7,3X4,3X0,9	ARANDELA ELASTICA 7,3X4,3X0,9
	9	60ND02511	3	VITE TCEI M6X1X30	SCREW TCEI M6X1X30	VIS TCEI M6X1X30	SCHRAUBE TCEI M6X1X30	TORNILLO TCEI M6X1X30
	10	62NA15767	3	RONDELLA 11X6,4X0,5	WASHER 11X6.4X0.5	RONDELLE 11X6,4X0,5	SCHEIBE 11X6,4X0,5	ARANDELA 11X6,4X0,5
	11	8000H3679	1	DADO	NUT	ECROU	MUTTER	TUERCA
	12	8000H3680	1	RONDELLA	WASHER	RONDELLE	SCHEIBE	ARANDELA
	13	8A0078647	6	VITE	SCREW	VIS	SCHRAUBE	TORNILLO
	14	65N121007	1	CHIAVETTA	KEY, WOODRUFF	CLAVETTE WOODRUFF	KEIL WOODRUFF	CHAVETA WOODRUFF
	15	8A0084828	1	MASSA SUPPLEMENTARE	ADDITIONAL WEIGHT	MASSE SUPPLEMENTAIRE	MASSE ZUSAETLICH	MASA ADICIONAL
	16	800083136	1	RUOTA LIBERA	CLUTCH, ONE WAY	ROUE LIBRE	EINWEGKUPPLUNG	EMBRAGUE, UNA VIA
	17	800086051	1	SPINA RIFERIMENTO 8X10	PIN DOWEL 8X10	GOUJON, ASSEMBLAGE 8X10	BEZUGSSTIFT 8X10	PASADOR ESPIGA REFERENCIA 8X10
	18	8000A5015	1	LIMITATORE DI COPPIA Z17/52	TORQUE LIMITER Z17/52	LIMITEUR DE COUPLE Z17/52	DREHMOMENTBEGRENZER Z17/52	LIMITADOR DE PAR Z17/52
	19	66ND21196	1	ANELLO SEEGER 13MM	CIRCLIP 13MM	CIRCLIP 13MM	SPRENGRING 13MM	ANILLO SEEGER 13MM
	20	800084831	1	INGRANAGGIO RINVIO Z27	IDLE GEAR T27	PIGNON INTERMEDIAIRE D27	FREILAUFRAD Z27	ENGRANAJE INTERMEDIO D27
	21	8F0009408	1	RONDELLA 22X14,5X1	WASHER 22X14.5X1	RONDELLE 22X14,5X1	SCHEIBE 22X14,5X1	ARANDELA 22X14,5X1
	22	800089012	1	INGRANAGGIO RINVIO Z20	IDLE GEAR T22	PIGNON INTERMEDIAIRE D22	FREILAUFRAD Z22	ENGRANAJE INTERMEDIO D22
	23	800084597	1	GABBIA A RULLI 28X34X20	BEARING, NEEDLE 28X34X20	ROULEMENT A AIGUILLES 28X34X20	NADELLAGER 28X34X20	COJINETE DE AGUJAS 28X34X20
	24	8A0084473	1	RONDELLA RASAMENTO	WASHER, THRUST	RONDELLE BUTEE	DISTANZSCHEIBE	ARANDELA SEPARACION
	25	800089011	1	INGRANAGGIO RUOTA LIBERA Z62	GEAR, FREE-WHEEL T62	PIGNON DE ROUE LIBRE D62	ZAHNRAD FREILAUFRAD Z62	ENGRANAJE RUEDA LIBRE D62
	26	800048591	2	RONDELLA ELASTICA 10X6,4X0,5	SPRING WASHER 10X6.4X0.5	RONDELLE ELASTIQUE 10X6,4X0,5	FEDERSCHEIBE 10X6,4X0,5	ARANDELA ELASTICA 10X6,4X0,5
	27	8000A1017	2	BOCCOLA	BUSH	DOUILLE	BUCHSE	BUJE
	28	Z00062729	1	VITE TEF M6X1X25 CH8	SCREW TEF M6X1X25 CH8	VIS TEF M6X1X25 CH8	SCHRAUBE TEF M6X1X25 CH8	TORNILLO TEF M6X1X25 CH8
	29	8000H1772	1	MOTORINO AVVIAMENTO	STARTING MOTOR	DEMARREUR ELECTRIQUE	ANLASSERMOTOR	MOTOR ARRANQUE
	30	Z00062728	1	VITE TEF M6X1X20 CH8	SCREW TEF M6X1X20 CH8	VIS TEF M6X1X20 CH8	SCHRAUBE TEF M6X1X20 CH8	TORNILLO TEF M6X1X20 CH8

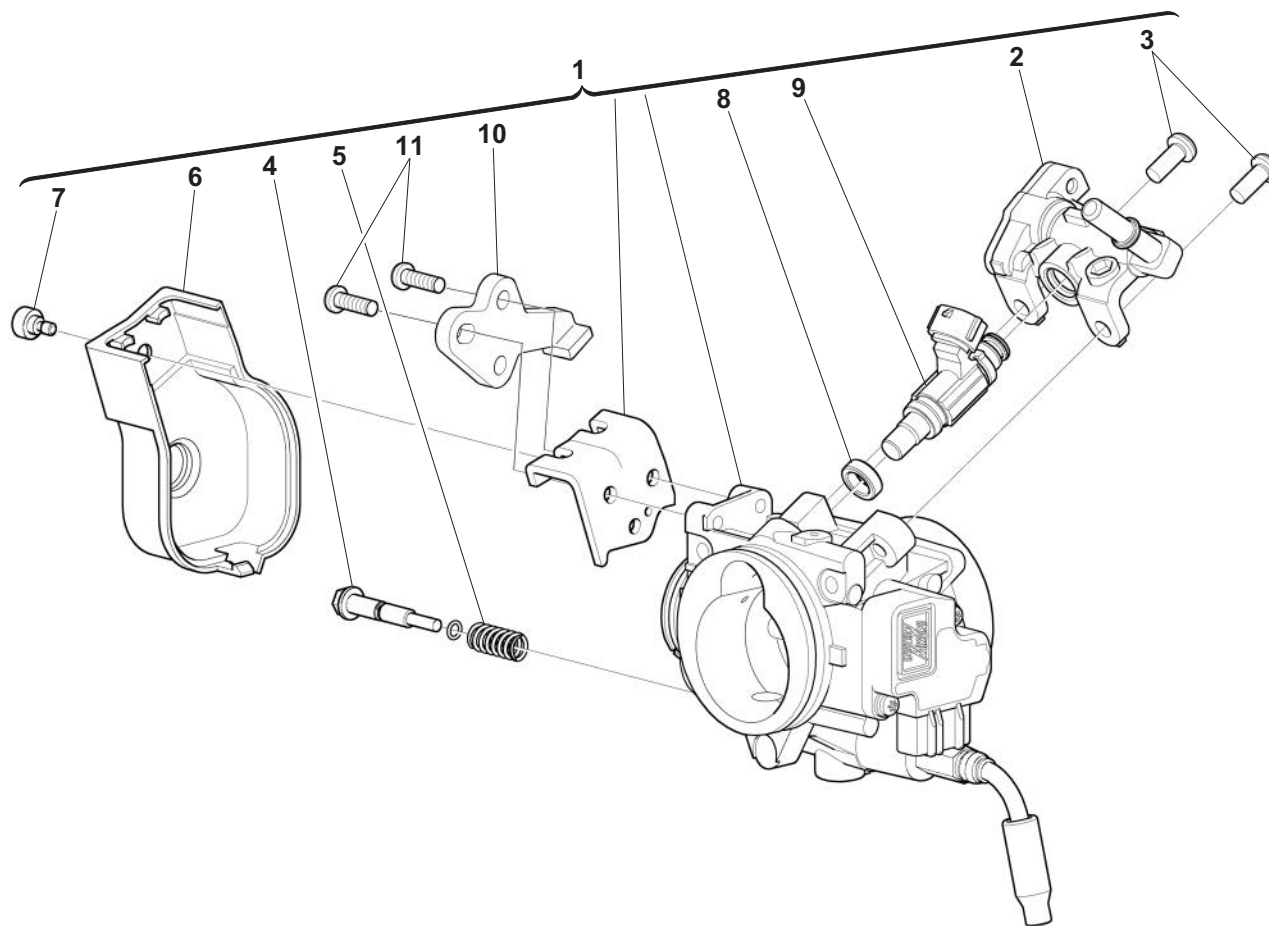



Superdual 2017

CORPO FARFALLATO - THROTTLE BODY  
CORP PAPILLON - DROSSELKLAPPENKÖRPER  
CUERPO OSCILANTE

TAVOLA  
DRAWING  
TABLE  
BILD  
TABLA

13

Note Notes Marke Notas	Pos. No. Index Pos.	N. Cod. Code No. Nr. Code Code Nr N. Cod.	Q.tà Q.ty Q.te M.ge C.ad	DENOMINAZIONE	NAME	DESIGNATION	BESHREIBUNG	DENOMINACION
	1	8000H1239	1	CORPO FARFALLATO	THROTTLE BODY	CORPS A PAPIILLON	DROSSELKOERPER	CUERPO MARIPOSA
	2	8000H2382	1	FUEL RAIL	PIPE-INJECTION	FUEL RAIL	FUEL RAIL	FUEL RAIL
	3	8000A9258	2	VITE	SCREW	VIS	SCHRAUBE	TORNILLO
	4	8000A9259	1	VITE	SCREW	VIS	SCHRAUBE	TORNILLO
	5	8000A9260	1	MOLLA	SPRING	RESSORT	FEDER	MUELLE
	6	8000A9261	1	COPERCHIO	COVER	COUVERCLE	DECKEL	CUBIERTA
	7	8000A9262	1	VITE	SCREW	VIS	SCHRAUBE	TORNILLO
	8	8000A9263	2	GUARNIZIONE INIETTORE	GASKET, INJECTOR	JOINT INJECTEUR	DICHTUNG, EINSPRITZDUESE	JUNTA INYECTOR
	9	8000A9264	1	INIETTORE	INJECTOR, FUEL	INJECTEUR	EINSPRITZDUESE	INYECTOR
	10	8000H2336	1	PIASTRINA LIMITATRICE	RELIEF PLATE	PLAQUETTE DOSEUR	BEGRENZUNGSLAETTCHEN	PLACA LIMITADORA
	11	8000A9699	2	VITE	SCREW	VIS	SCHRAUBE	TORNILLO

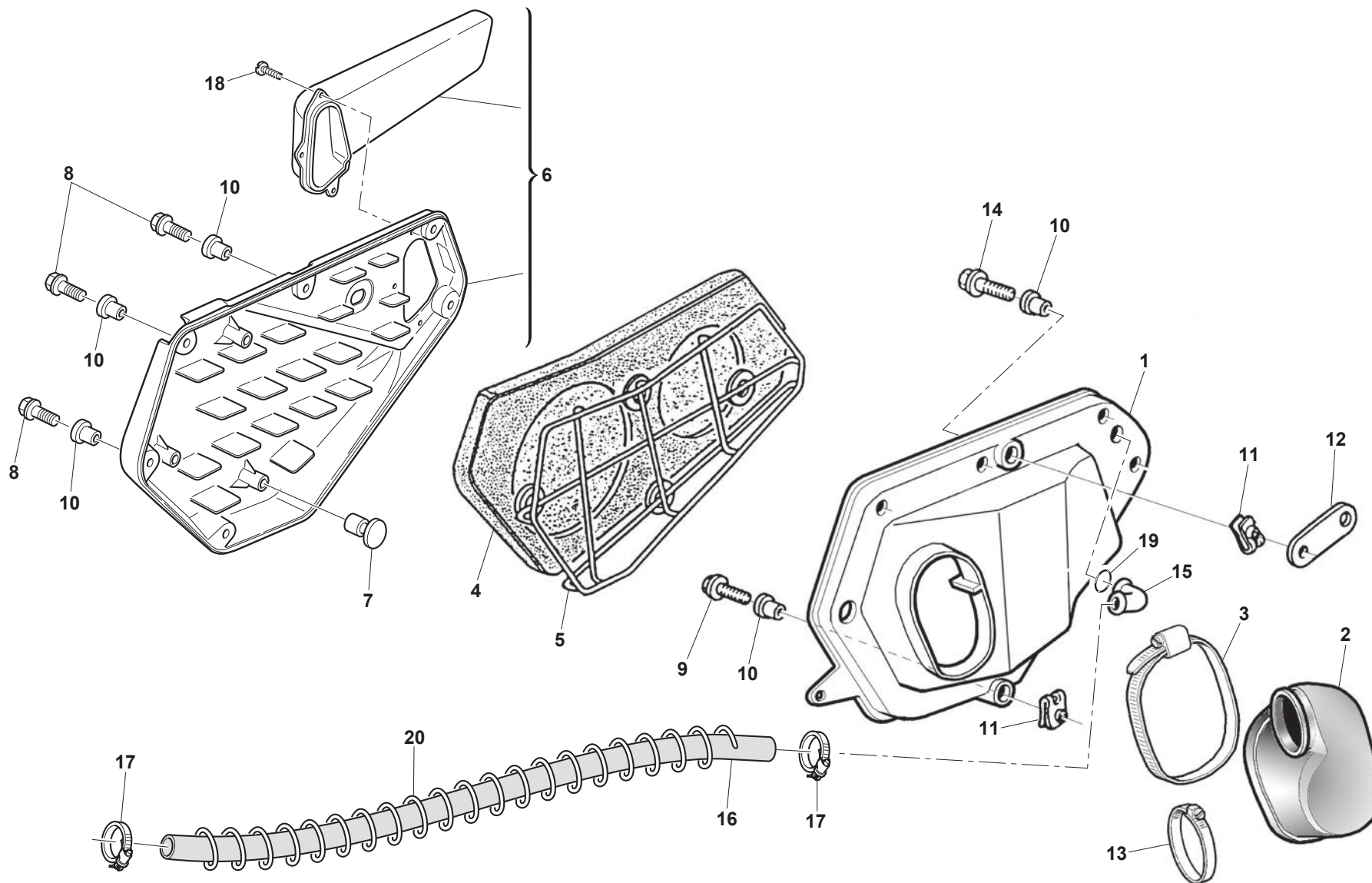



**FILTRO ARIA - AIR FILTER**  
**FILTRE AIRE - LUFTFILTER**  
**FILTRO DE AIRE**

Note Notes Marke Notas	Pos. No. Index Pos.	N. Cod. Code No. Nr. Code Code Nr N. Cod.	Q.tà Q.ty Q.te M.ge C.ad	DENOMINAZIONE	NAME	DESIGNATION	BESHREIBUNG	DENOMINACION
	1	8000H2367	1	BASE CASSETTA FILTRO ARIA	CASE, AIR CLEANER	BOITE FILTRE A AIR	LUFTFILTERGEHAUSE	CAJA FILTRO AIRE
	2	8000H0914	1	MANICOTTO CASSETTA FILTRO	TUBE, AIR CLEANER JOINT	RACCORD BOITE FILTRE A AIR	VERBINDUNGS, LUFTFILTERGEHAUSE	MANGUERA, CAJA FILTRO AIRE
	3	8F0099475	1	FASCETTA NEMO 60/145 mm	CLAMP NEMO 60/145 mm	COLLIER NEMO 60/145 mm	SHELLE NEMO 60/145 mm	ABRAZADORA NEMO 60/145 mm
	4	800092948	1	FILTRO ARIA	FILTER, AIR	FILTRE A AIR	LUFTFILTER	FILTRO AIRE
	5	8000H2366	1	SUPPORTO FILTRO ARIA	STAY, AIR CLEANER	APPUI FILTRE A AIR	STUETZE, LUFTFILTEREINSATZ	SOPORTE FILTRO AIRE
	6	F000A00052	1	COPERCHIO CASSETTA FILTRO ARIA	COVER, AIR FILTER CASE	COUVERCLE BOITE FILTRE AIR	DECKEL LUFTFILTERGEHAUSE	CUBIERTA CAJA FILTRO AIRE
	7	800067970	3	GOMMINO ANTIVIBRANTE	PAD, VIBRATION DAMPER	CAOUTCHOU ANTI-VIBRATION	SCHWINGUNGSDAEMPFERGUMMI	GOMA ANTI-VIBRACION
	8	Z00062727	6	VITE TEF M6X1X16 CH8	SCREW TEF M6X1X16 CH8	VIS TEF M6X1X16 CH8	SCHRAUBE TEF M6X1X16 CH8	TORNILLO TEF M6X1X16 CH8
	9	ZB0067545	1	VITE TEF M6X55	SCREW TEF M6X55	VIS TEF M6X55	SCHRAUBE TEF M6X55	TORNILLO TEF M6X55
	10	8000H3017	8	BOCCOLA	BUSH	DOUILLE	BUCHSE	BUJE
	11	U00046893	2	DADO ELASTICO M6X1	CLIP NUT M6X1	JONC M6X1	KLEMME M6X1	PREASIENTO M6X1
	12	151580301	1	PIASTRINA	PLATE	PLAQUETTE	PLAETTCHEN	PLETINA
	13	8E0099475	1	FASCETTA NEMO 40/80 mm	CLAMP NEMO 40/80 mm	COLLIER NEMO 40/80 mm	SHELLE NEMO 40/80 mm	ABRAZADERA NEMO 40/80 mm
	14	Z00062727	1	VITE TE M6X1X16 CH8	SCREW TE M6X1X16 CH8	VIS TE M6X1X16 CH8	SCHRAUBE TE M6X1X16 CH8	TORNILLO TE M6X1X16 CH8
	15	8000A7039	1	RACCORDO SFIATO	JOINT, BREATHER	RACCORD, RENIFLARD	ANSCHLUSS, BELUFTUNG	RACOR RESPIRADERO
	16	8B00H1033	1	TUBO SFIATO 450 mm	HOSE, BREATHER 450 mm	TUYAU RENIFLARD 450 mm	ENTLUEFTERSCHLAUCH 450 mm	TUBO RESPIRADERO 450 mm
	17	8A0092249	2	FASCETTA CLIC R 96-175 mm	HOSE CLAMP R 96-175 mm	COLLIER CLIC R 96-175 mm	SCHLAUCHSHELLE R 96-175 mm	ABRAZADERA CLIC R 96-175 mm
	18	8A00H0534	3	VITE M5X12	SCREW M5X12	VIS M5X12	SCHRAUBE M5X12	TORNILLO M5X12
	19	800001199	1	ANELLO O-RING	O RING	JOINT TORIQUE	O-RING	JUNTA TORICA
	20	8000H4196	1	SPIRALE PROTEZIONE TUBO	SPRING, HOSE PROTECTOR	SPIRALE PROTECTEUR TUYAU	SPIRALLINIE, SCHLAUCHSCHUTZ	ESPIRAL PROTECCION TUBO

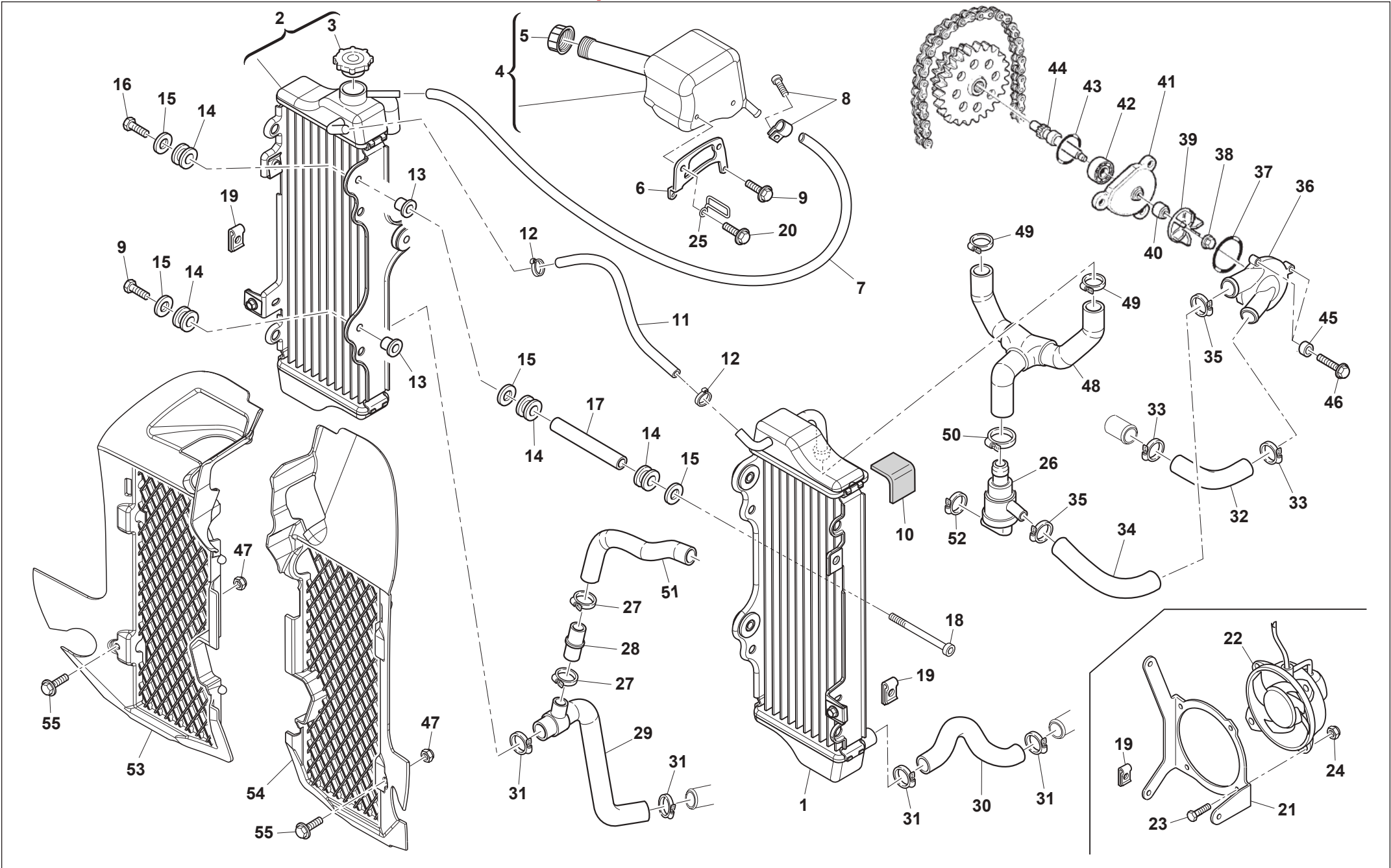



**Superdual 2017**

**IMPIANTO DI RAFFREDDAMENTO - COOLING SYSTEM  
 INSTALLATION DE REFRIGERATION - SCHMIERUNGSSYSTEM  
 EQUIPO DE ENFRIAMIENTO**

TAVOLA  
 DRAWING  
 TABLE  
 BILD  
 TABLA

**15**

Note Notes Notas	Pos. No. Index Pos.	N. Cod. Code No. Nr. Code Code Nr N. Cod.	Q.tà Q.ty M.ge C.ad	DENOMINAZIONE	NAME	DESIGNATION	BESHREIBUNG	DENOMINACION
	1	F000P00022	1	RADIATORE ACQUA SINISTRO	RADIATOR, WATER, LH	RADIATEUR EAU GAUCHE	WASSERKUEHLER LINKS	RADIADOR AGUA IZQUERDO
	2	F000P00023	1	RADIATORE ACQUA DESTRO	RADIATOR, WATER,RH	RADIATEUR EAU DROIT	WASSERKUEHLER RECHTS	RADIADOR AGUA DERECHO
	3	F000P00717	1	TAPPO RADIATORE ACQUA	CAP, RADIATOR	BOUCHON RADIATEUR	KUEHLERPROPFEN	TAPON RADIADOR
	4	8000H1041	1	VASO ESPANSIONE	TANK, WATER RESERVOIR	VASE EXPANSION	AUSDEHNGEFAESS	VASO EXPANSION
	5	800040427	1	TAPPO VASO ESPANSIONE	CAP, WATER RESERVOIR TANK	BOUCHON VASE EXPANSION	PFROPFEN, AUSDEHNGEFAESS	TAPON VASO EXPANSION
	6	8000H0971	1	SUPPORTO VASO ESPANSIONE	BRACKET, WATER TANK	SUPPORT RESERVOIR EAU	WASSERTANKHALTERUNG	SOPORTE DEPOSITO AGUA
	7	8000A1281	1	TUBO	PIPE	TUYAU	ROHR	TUBO
	8	8B0091687	1	FASCETTA STRINGITUBO INOX D10	CLAMP, HOSE	COLLIER A VIS	SCHRAUBENSHELLE	ABRAZADERA CON ROSCA
	9	Z00062725	6	VITE TEF M6X1,00X10 CH8	SCREW TEF M6X1.00X10 CH8	VIS TEF M6X1,00X10 CH8	SCHRAUBE TEF M6X1,00X10 CH8	TORNILLO TEF M6X1,00X10 CH8
	10	8A0087072	2	TAMPONE ADESIVO	GROMMET ADHESIVE	CAOUTCHOUC ADHESIF	KLEBERGUMMI	GOMAADHESIVA
	11	8000H1298	1	TUBO RACCORDO RADIATORI	PIPE	TUYAU	ROHR	TUBO
	12	8000H1981	2	FASCETTA	CLAMP	COLLIER	SHELLE	ABRAZADERA
	13	8G0059802	4	BOCCOLA	BUSHING	DOUILLE	BUCHSE	BUJE
	14	F000P00025	6	SILENTBLOCK RADIATORE	RUBBER, RADIATOR MOUNTING	CAOUTCHOUC MONTAGE RADIATEUR	SCHWINGUNGSDAEMPFER, KUEHLER	CASQUILLO ELASTICO RADIADOR
	15	Z00059801	5	RONDELLA 22X6,5X1	WASHER 22X6.5X1	RONDELLE 22X6,5X1	SCHEIBE 22X6,5X1	ARANDELA 22X6,5X1
	16	Z00062729	2	VITE TEF M6X1X20 CH8	SCREW TEF M6X1X20 CH8	VIS TEF M6X1X20 CH8	SCHRAUBE TEF M6X1X20 CH8	TORNILLO TEF M6X1X20 CH8
	17	800066858	1	DISTANZIALE 10X7X64	SPACER 10X7X64	ENTRETOISE 10X7X64	ABSTANDHALTER 10X7X64	DISTANCIADOR 10X7X64
	18	60ND02525	1	VITE TCEI M6X1X100	SCREW TCEI M6X1X100	VIS TCEI M6X1X100	SCHRAUBE TCEI M6X1X100	TORNILLO TCEI M6X1X100
	19	U00046893	3	DADO ELASTICO M6X1	CLIP NUT M6X1	JONC M6X1	KLEMME M6X1	PREASIENTO M6X1
	20	ZS0067545	2	VITE TEF M6X1,00X10 CH8	SCREW TEF M6X1.00X10 CH8	VIS TEF M6X1,00X10 CH8	SCHRAUBE TEF M6X1,00X10 CH8	TORNILLO TEF M6X1,00X10 CH8
	21	8000H0911	1	SUPPORTO ELETTROVENTOLA	BRACKET ELECTRIC FAN	SUPPORT ELECTROVENTILATEUR	HALTER ELEKTROLUEFTER	SOPORTE VENTILADOR ELECTRICO
	22	8000A7715	1	ELETTROVENTOLA	FAN	VENTILATEUR	KUHLUNGSFLÜGEL	AVENTADÝR
	23	60ND01030	4	VITE TE M4X0,7X25	SCREW TE M4X0.7X25	VIS TE M4X0,7X25	SCHRAUBE TE M4X0,7X25	TORNILLO TE M4X0,7X25
	24	Z00040717	4	DADO FLANGIATO M4X0,7	NUT FLANGE M4X0.7	ECROU BRIDE M4X0,7	GEFLANSCHTE MUTTER M4X0,7	TUERCA CON REBORDE M4X0,7
	25	800086951	1	PASSACAVO	FAIRLEAD	PASSE-CÁBLE	KABELFÜHRUNG	PRENSA-CABLE
	26	8B0075984	1	TERMOSTATO	THERMOSTAT	THERMOSTAT	THERMOSTAT	TERMOSTATO
	27	8000H1981	2	FASCETTA HOP 8-10/18 mm	CLAMP HOP 8-10/18 mm	COLLIER HOP 8-10/18 mm	SHELLE HOP 8-10/18 mm	ABRAZADERA HOP 8-10/18 mm
	28	800094680	1	RACCORDO TUBO	JOINT, HOSE	RACCORD TUYAU	ANSCHLUSS, SCHLAUCH	RACOR MANGUERA
	29	8000H1205	1	TUBO ACQUA DESTRO	HOSE, WATER RH	TUYAU EAU DROIT	SCHLAUCH, WASSER, RECHTS	MANGUERA AGUA DERECHO
	30	8000H1206	1	TUBO ACQUA RADIATORE-POMPA	HOSE-COOLING, RADIATOR-PUMP	TUYAU EAU RADIATEUR-POMPE	SCHLAUCH, WASSER KUEHLER-PUMPE	MANGUERA AGUA BOMBA/RADIADOR
	31	8A0099475	4	FASCETTA HOP 8-12/22 mm	CLAMP HOP 8-12/22 mm	COLLIER HOP 8-12/22 mm	SHELLE HOP 8-12/22 mm	ABRAZADERA HOP 8-12/22 mm
	32	8A0099708	1	TUBO ACQUA TESTA POMPA	HOSE-COOLING CYLINDER HEAD PUMP	TUYAU EAU COULASSE POMPE	WASSERLEITUNG ZYLINDERKOPF PUMPE	MANGUERA AGUA CULATA BOMBA
	33	8B0099475	2	FASCETTA HOP 8-16/27 mm	CLAMP HOP 8-16/27 mm	COLLIER HOP 8-16/27 mm	SHELLE HOP 8-16/27 mm	ABRAZADERA HOP 8-16/27 mm

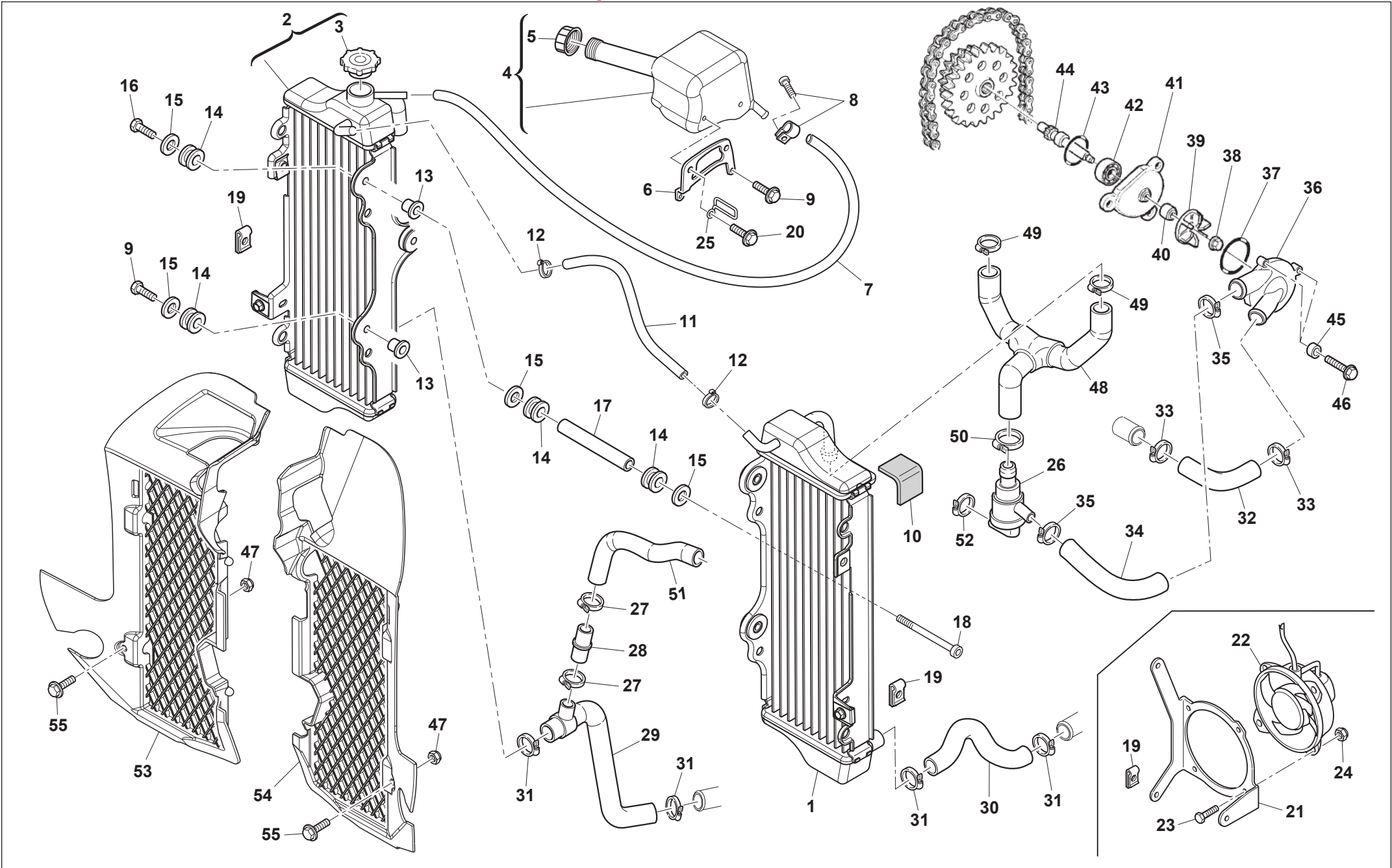



Superdual 2017

**IMPIANTO DI RAFFREDDAMENTO - COOLING SYSTEM  
 INSTALLATION DE REFRIGERATION - SCHMIERUNGSSYSTEM  
 EQUIPO DE ENFRIAMIENTO**

TAVOLA  
 DRAWING  
 TABLE  
 BILD  
 TABLA

15

Note Notes Marke Notas	Pos. No. Index Pos.	N. Cod. Code No. Nr. Code Code Nr N. Cod.	Q.tà Q.ty Q.te M.ge C.ad	DENOMINAZIONE	NAME	DESIGNATION	BESHREIBUNG	DENOMINACION
	34	8000H1529	1	TUBO ACQUA TERMOSTATO POMPA	HOSE-COOLING THERMOSTAT PUMP	TUYAU EAU THERMOSTAT POMPE	SCHLAUCH, WASSER THERMOSTAT POMPE	MANGUERA AGUA TERMOSTATO BOMBA
	35	8B0099475	2	FASCETTA 8-16/27	CLAMP 8-16/27	COLLIER 8-16/27	SHELLE 8-16/27	ABRAZADERA 8-16/27
	36	8000H1958	1	CORPO POMPA ACQUA	PUMP BODY	CORPS POMPE	PUMPENKÖRPER	CORPO BOMBA
	37	800027122	1	ANELLO O-RING 3237 60X2,62	O-RING 3237 60X2.62	JOINT TORIQUE 3237 60X2,62	O-RING 3237 60X2,62	JUNTA TORICA 3237 60X2,62
	38	Z00056443	1	DADO AUTOBLOCCANTE M5X0,8 H6	NUT, SELF LOCKING M5X0.8 H6	ECROU AUTOBLOQUANT M5X0,8 H6	SELBSTSPERRENDE MUTTER M5X0,8 H6	TUERCA AUTOBLOQUEANTE M5X0,8 H6
	39	8000H1462	1	GIRANTE POMPA ACQUA	IMPELLER, WATER PUMP	TURBINE POMPE A EAU	WASSERPUMPE LAUFSCHWUNGRAD	ROTOR BOMBA AGUA
	40	800053339	1	PARAOLIO 8X16X10	OIL SEAL 8X16X10	BAGUE D'ETANCHEITE 8X16X10	WELLENDICHRING 8X16X10	RETEN DE ACEITE 8X16X10
	41	800091565	1	FLANGIA SUPPORTO POMPA ACQUA	FLANGE, WATER PUMP	BRIDE POMPE A EAU	FLANSCH, WASSERPUMPE	BRIDA BOMBA AGUA
	42	800034317	1	CUSCINETTO A SFERE 12X28X8	BEARING, BALL 12X28X8	ROULEMENT A BILLES 12X28X8	KUGELLAGER 12X28X8	COJINETE DE BOLAS 12X28X8
	43	800040007	1	ANELLO O-RING 2125	O-RING 2125	JOINT TORIQUE 2125	O-RING 2125	JUNTA TORICA 2125
	44	8000A4789	1	ALBERO POMPA ACQUA	PUMP SHAFT	ARBRE POMPE	WELLE	ALBOR BOMBA
	45	161795501	2	BOCCOLA 8X6,4X6	BUSH 8X6.4X6	DOUILLE 8X6,4X6	BUCHSE 8X6,4X6	CASQUILLO 8X6,4X6
	46	Z00062730	3	VITE TE M6X1X30 CH8	SCREW TE M6X1X30 CH8	VIS TE M6X1X30 CH8	SCHRAUBE TE M6X1X30 CH8	TORNILLO TE M6X1X30 CH8
	47	Z00044240	2	DADO	NUT	ECROU	MUTTER	TUERCA
	48	8000H1202	1	TUBO ACQUA	HOSE, WATER	TUYAU EAU	SCHLAUCH, WASSER	MANGUERA AGUA
	49	8A0099475	2	FASCETTA HOP 8-12/22 mm	CLAMP HOP 8-12/22 mm	COLLIER HOP 8-12/22 mm	SHELLE HOP 8-12/22 mm	ABRAZADERA HOP 8-12/22 mm
	50	8B0099475	2	FASCETTA HOP 8-16/27 mm	CLAMP HOP 8-16/27 mm	COLLIER HOP 8-16/27 mm	SHELLE HOP 8-16/27 mm	ABRAZADERA HOP 8-16/27 mm
	51	8000H1203	1	TUBO BYPASS	PIPE	TUYAU	ROHR	TUBO
	52	8A0099475	1	FASCETTA HOP 8-10/18 mm	CLAMP HOP 8-10/18 mm	COLLIER HOP 8-10/18 mm	SHELLE HOP 8-10/18 mm	ABRAZADERA HOP 8-10/18 mm
	53	F000P01421	1	GRIGLIA RADIATORE DX	RH RADIATOR GRID	GRILLE RADIATEUR D	GITTER KÜHLER RE	REJILLA RADIADOR DCH.
	54	F000P01423	1	GRIGLIA RADIATORE SX	LH RADIATOR GRID	GRILLE RADIATEUR G	GITTER KÜHLER LI	REJILLA RADIADOR IZQ.
	55	ZH0067545	2	VITE M6X12	SCREW M6x12	VIS M6x12	SCHRAUBE M6x12	TORNILLO M6x12

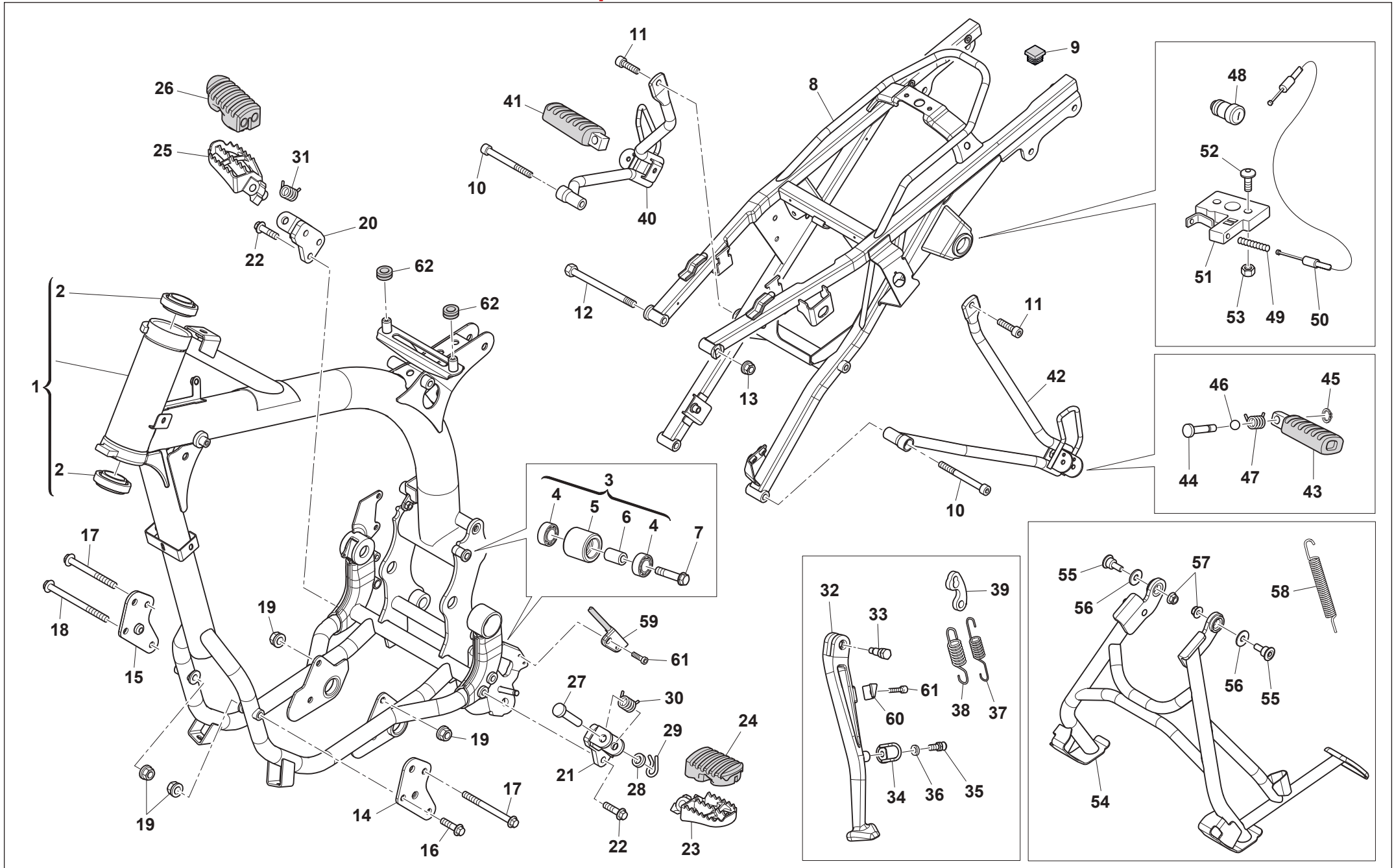

**Superdual 2017**

**TELAIO, PEDANE - FRAME, FOOT RESTS  
CADRE, REPOSE PIEDS - RAHMEN, FUSSBRETT  
BASTIDOR, REPOSAPIES**

TAVOLA  
DRAWING  
TABLE  
BILD  
TABLA**16A**

Note Notes Notes Marke Notas	Pos. No. N. Index Pos.	N. Cod. Code No. Nr. Code Code Nr N. Cod.	Q.tà Q.ty Q.te M.ge C.ad	DENOMINAZIONE	NAME	DESIGNATION	BESHREIBUNG	DENOMINACION
	1	F000A01238	1	TELAIO CON CUSCINETTI	FRAME WITH BEARINGS	CHÂSSIS AVEC ROULEMENTS	RAHMEN MIT LAGERN	CHASIS CON COJINETES
	2	800087243	2	CUSCINETTO A RULLI CONICI	TAPERED ROLLER BEARING	ROULEMENT À ROULEAUX CONIQUES	KEGELROLLENLAGER	COJINETE DE RODILLOS CÓNICOS
	3	8C0059432	2	RULLO CATENA COMPLETO	CHAIN ROLLER ASSY	GALET DE CHÂÎNE COMPLET	KETTENROLLE KOMPLETT	RODILLO CADENA COMPLETO
	4	8AA059433	1	RULLO CATENA	CHAIN ROLLER	GALET DE CHÂÎNE	KETTENROLLE	RODILLO CADENA
	5	8A0059434	1	DISTANZIALE	SPACER	ENTRETOISE	ABSTANDHALTER	DISTANCIADOR
	6	800063312	2	CUSCINETTO	BEARING	ROULEMENT	LAGER	COJINETE
	7	60ND02559	2	VITE TCEI M8x40	SCREW TCEI M8x40	VIS TCEI M8x40	SCHRAUBE TCEI M8x40	TORNILLO TCEI M8x40
	8	F000P00932	1	TELAIO POSTERIORE	REAR CHASSIS	CHÂSSIS ARRIÈRE	HINTERER RAHMEN	CHASIS TRASERO
	9	F000P01960	2	TAPPO QUADRO DI PLASTICA	PLUG	BOUCHON	STOPFEN	TAPON
	10	60ND02567	2	VITE TCEI M8x80	SCREW TCEI M8x80	VIS TCEI M8x80	SCHRAUBE TCEI M8x80	TORNILLO TCEI M8x80
	11	60ND02555	2	VITE TCEI M8x20	SCREW TCEI M8x20	VIS TCEI M8x20	SCHRAUBE TCEI M8x20	TORNILLO TCEI M8x20
	12	YA0069111	1	VITE TEF M8x140	FLANGED EXAGON HEAD SCREW M8x140	BOULON DE BRIDE M8x140	FLANSCHENSCHRAUBE M8x140	TORNILLO DE REBORDE M8x140
	13	Y00043928	1	DADO FRENATO M8	SELF-LOCKING NUT M8	ECROU AUTOBLOQUANT M8	SELBSTSICHERNDE MUTTER M8	TUERCA AUTOBLOCANTE M8
	14	F000P01137	1	PIASTRA MOTORE SINISTRA	L.H. ENGINE PLATE	PLAQUE MOTEUR G.	PLATTE MOTOR LINKE	PLACA MOTOR IZQ.
	15	FA00P01137	1	PIASTRA MOTORE DESTRA	R.H. ENGINE PLATE	PLAQUE MOTEUR D.	PLATTE MOTOR RECHTS	PLACA MOTOR DER.
	16	Z00062795	2	VITE TEF M8x50	FLANGED EXAGON HEAD SCREW M8x50	BOULON DE BRIDE M8x50	FLANSCHENSCHRAUBE M8x50	TORNILLO DE REBORDE M8x50
	17	YL0073458	2	VITE TEF M8x105	FLANGED EXAGON HEAD SCREW M8x105	BOULON DE BRIDE M8x105	FLANSCHENSCHRAUBE M8x105	TORNILLO DE REBORDE M8x105
	18	YP0073458	1	VITE TEF M8x135	FLANGED EXAGON HEAD SCREW M8x135	BOULON DE BRIDE M8x135	FLANSCHENSCHRAUBE M8x135	TORNILLO DE REBORDE M8x135
	19	Y00043928	5	DADO FRENATO M8	SELF-LOCKING NUT M8	ECROU AUTOBLOQUANT M8	SELBSTSICHERNDE MUTTER M8	TUERCA AUTOBLOCANTE M8
	20	F000P00206	1	SUPPORTO PEDANA DESTRA	R.H. FOOTREST SUPPORT	SUPPORT REPOSE-PIEDS DROITE	HALTERUNG FUßRASTE RECHTS	SOPORTE ESTRIBO DERECHA
	21	80B083987	1	SUPPORTO PEDANA SINISTRA	L.H. FOOTREST SUPPORT	SUPPORT REPOSE-PIEDS GAUCHE	HALTERUNG FUßRASTE LINKS	SOPORTE ESTRIBO IZQUIERDA
	22	8000B1959	4	VITE TEF M8x25	FLANGED EXAGON HEAD SCREW M8x25	BOULON DE BRIDE M8x25	FLANSCHENSCHRAUBE M8x25	TORNILLO DE REBORDE M8x25
	23	80A089962	1	PEDANA SINISTRA	L.H. FOOTREST	REPOSE-PIEDS GAUCHE	FUßRASTE LINKS	ESTRIBO IZQUIERDA
	24	F000P00138	1	GOMMINO PEDANA SINISTRA	LEFT FOOTREST RUBBER	CAOUTCHOUC	GUMMI	GOMA
	25	80A089953	1	PEDANA DESTRA	R.H. FOOTREST	REPOSE-PIEDS DROITE	FUßRASTE RECHTS	ESTRIBO DERECHA
	26	F000P00139	1	GOMMINO PEDANA DESTRA	RIGHT FOOTREST RUBBER	CAOUTCHOUC	GUMMI	GOMA
	27	Y00073140	2	PERNO ROTAZIONE PEDANA	PIN	AXE	BOLZEN	EJE
	28	ZA0001815	2	ROSETTA	WASHER	RONDELLE	UNTERLEGSSCHEIBE	ARANDELA
	29	64ND20068	2	COPIGLIA	SPLIT PIN	GOUPILLE	SPLINT	PASADOR
	30	800096907	1	MOLLA PEDANA SINISTRA	SPRING	RESSORT	FEDER	MUELLE
	31	800096908	1	MOLLA PEDANA DESTRA	SPRING	RESSORT	FEDER	MUELLE
	32	F000P01017	1	GAMBA LATERALE	SIDE LEG	BRANCHE LATÉRALE	FEDERBEIN SEITLICH	PATA LATERAL
	33	F000P01116	1	VITE ROTAZIONE CAVALLETTO LATERALE	SIDE STAND SCREW	VIS BÉQUILLE	SCHRAUBE STÄNDER	TORNILLO CABALLETE

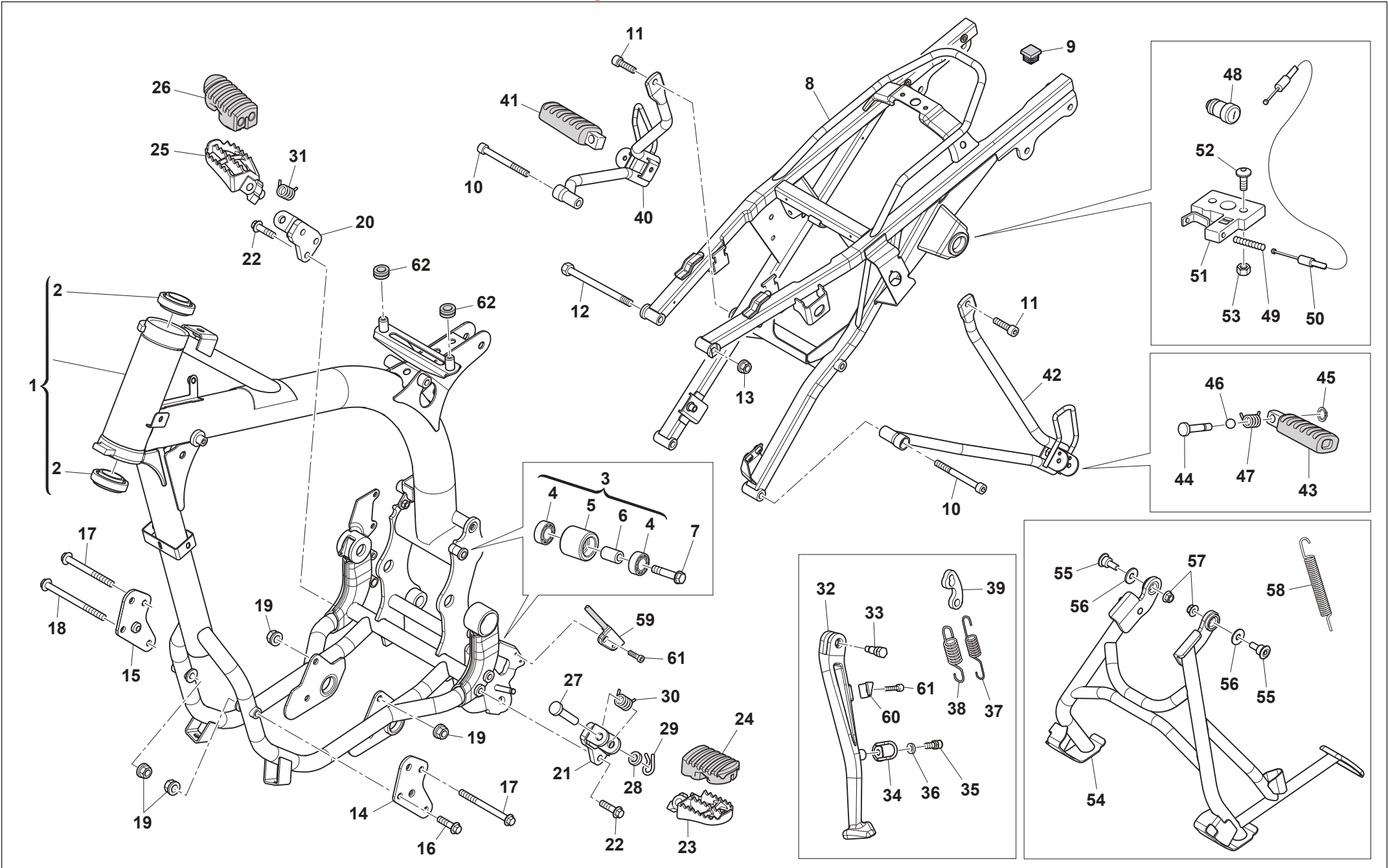

**Superdual 2017**

**TELAIO, PEDANE - FRAME, FOOT RESTS**  
**CADRE, REPOSE PIEDS - RAHMEN, FUSSBRETT**  
**BASTIDOR, REPOSAPIES**

TAVOLA  
DRAWING  
TABLE  
BILD  
TABLA

**16A**

Note Notes Notes Marke Notas	Pos. No. Index Pos.	N. Cod. Code No. Nr. Code Code Nr N. Cod.	Q.tà Q.ty Q.te M.ge C.ad	DENOMINAZIONE	NAME	DESIGNATION	BESHREIBUNG	DENOMINACION
	34	8000H2989	1	PIASTRINA	PLATE	PLAQUETTE	PLÄTTCHEN	PLACA
	35	8000H0235	1	PERNO	PIN	AXE	BOLZEN	EJE
	36	62ND15769	1	ROSETTA	WASHER	RONDELLE	UNTERLEGSSCHEIBE	ARANDELA
	37	8000A0268	1	MOLLA INTERNA	INTERNAL SPRING	RESSORT INTERIEUR	INTERNE FEDER	MUELLE INTERNO
	38	8000A0269	1	MOLLA ESTERNA	EXTERNAL SPRING	RESSORT EXTERIEUR	EXTERNE FEDER	MUELLE EXTERNO
	39	8000A0267	1	PIASTRINA	PLATE	PLAQUETTE	PLÄTTCHEN	PLACA
	40	F000P01018	1	SUPPORTO PEDANA DESTRA	R.H. FOOTREST SUPPORT	SUPPORT REPOSE-PIEDS DROITE	HALTERUNG FUßRASTE RECHTS	SOPORTE ESTRIBO DERECHA
	41	8A0085928	1	PEDANA PASSEGGERO DESTRA	PASSENGER R.H. FOOTREST	REPOSE-PIEDS DROIT	FUßRASTE RECHTS	ESTRIBO DERECHA
	42	F000P01019	1	SUPPORTO PEDANA SINISTRA	L.H. FOOTREST SUPPORT	SUPPORT REPOSE-PIEDS GAUCHE	HALTERUNG FUßRASTE LINKS	SOPORTE ESTRIBO IZQUIERDA
	43	8A0085929	1	PEDANA PASSEGGERO SINISTRA	PASSENGER L.H. FOOTREST	REPOSE-PIEDS GAUCHE	FUßRASTE LINKS	ESTRIBO IZQUIERDA
	44	ZB0053546	2	PERNO	PIN	AXE	BOLZEN	EJE
	45	66ND21308	2	ANELLO ELASTICO	CIRCLIP	CIRCLIP	SPRENGRING	ANILLO ELASTICO
	46	6BN021507	2	SFERA ACCIAIO 1/4"	1/4" STEEL BALL	BILLE 1/4"	KUGEL 1/4"	BOLA 1/4"
	47	800062655	2	MOLLA	SPRING	RESSORT	FEDER	MUELLE
	48	8000H1798	1	SERRATURA SELLA	SADDLE LOCK	SERRURE SELLE	SITZBANKSCHLOSS	CERRADURA ASIENTO
	49	8000H2015	1	MOLLA	SPRING	RESSORT	FEDER	MUELLE
	50	8000H2016	1	CAVO APERTURA SELLA	CABLE, SADDLE OPENING	CABLE OUVERTURE SELLE	KABEL SITZBANKOFFNUNG	CABLE ABERTURE ASIENTO
	51	8000H2127	1	SERRATURA SELLA	SADDLE LOCK	SERRURE SELLE	SITZBANKSCHLOSS	CERRADURA ASIENTO
	52	Z00055697	2	VITE TBEI M6x25	BOLT TBEI M6x25	VIS TBEI M6x25	SCHRAUBE TBEI M6x25	TORNILLO TBEI M6x25
	53	Z00044240	2	DADO AUTOBLOCCANTE M6	SELF-LOCKING NUT M6	ECROU AUTOBLOQUANT M6	SELBSTSICHERNDE MUTTER M6	TUERCA AUTOBLOCANTE M6
	54	F000P00933	1	CAVALLETTO CENTRALE	CENTRAL STAND	BÉQUILLE CENTRALE	MITTELSTÄNDER	CABALLETE CENTRAL
	55	F000P01542	2	VITE	BOLT	VIS	SCHRAUBE	TORNILLO
	56	Z00047317	2	ROSETTA	WASHER	RONDELLE	UNTERLEGSSCHEIBE	ARANDELA
	57	Y00043928	2	DADO FRENATO M8	SELF-LOCKING NUT M8	ECROU AUTOBLOQUANT M8	SELBSTSICHERNDE MUTTER M8	TUERCA AUTOBLOCANTE M8
	58	F000P01132	2	MOLLA CAVALLETTO CENTRALE	CENTRAL STAND SPRING	RESSORT BÉQUILLE CENTRALE	FEDER	MUELLE CABALLETE CENTRAL
	59	E000P01648	1	SENSORE CAVALLETTO LATERALE	SENSOR LATERAL STAND	CAPTEUR BÉQUILLE	STÄNDER SENSOR	SENSOR CABALLETE LATERAL
	60	E000P01117	1	MAGNETE	MAGNET	AIMANT	MAGNET	IMÁN
	61	60ND02461	3	VITE TCEI M4x10	SCREW TCEI M4x10	VIS TCEI M4x10	SCHRAUBE TCEI M4x10	TORNILLO TCEI M4x10
	62	8000H2374	2	ANTIVIBRANTE	SILENT-BLOCK	ANTIVIBRATION	SCHWINGUNGSDAMFER	ANTIVIBRADOR

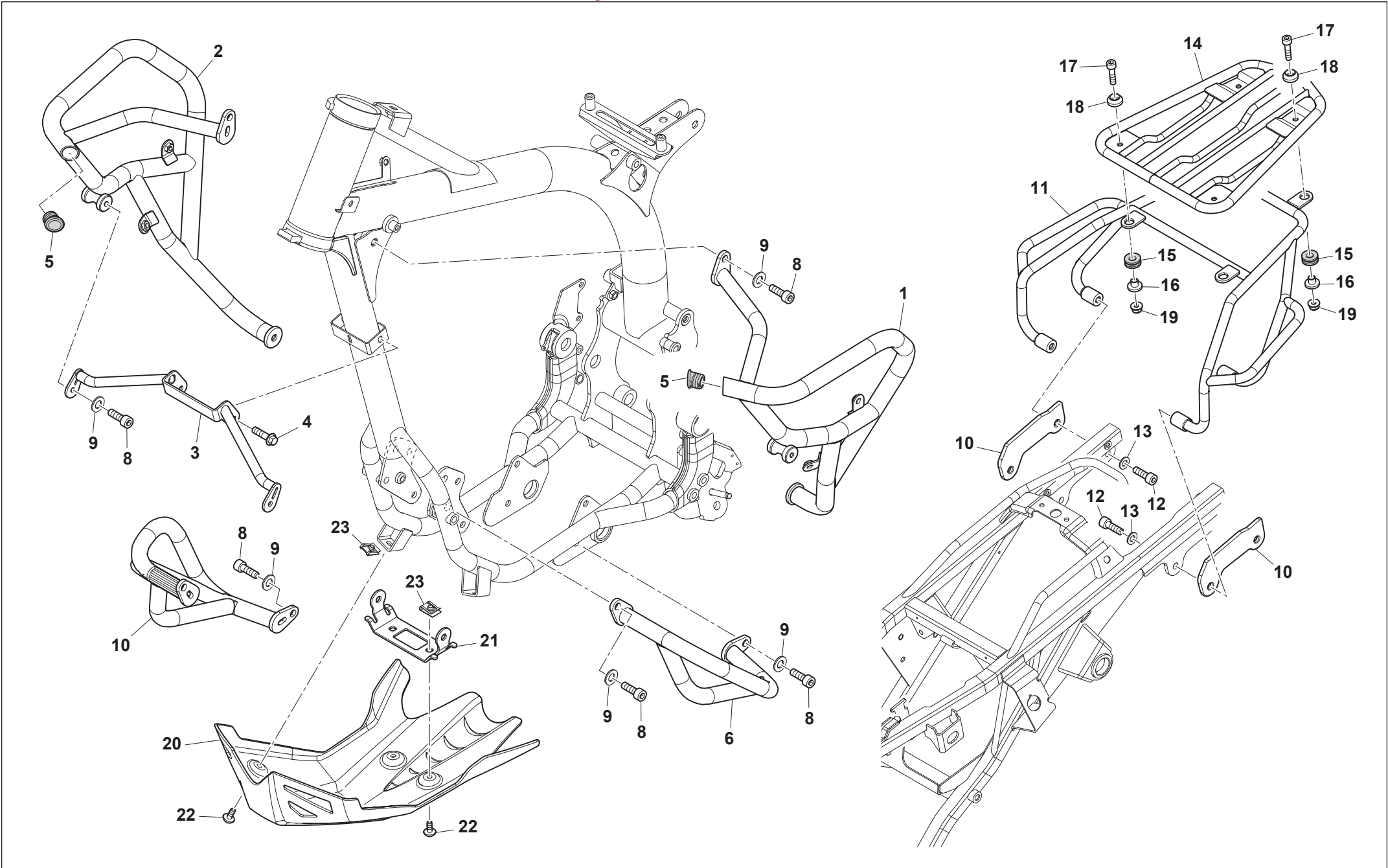





Superdual 2017

**TELAIO, PEDANE - FRAME, FOOT RESTS  
CADRE, REPOSE PIEDS - RAHMEN, FUSSBRETT  
BASTIDOR, REPOSAPIES**

TAVOLA  
DRAWING  
TABLE  
BILD  
TABLA **16B**

Note Notes Notes Marke Notas	Pos. No. N. Index Pos.	N. Cod. Code No. Nr. Code Code Nr N. Cod.	Q.tà Q.ty Q.te M.ge C.ad	DENOMINAZIONE	NAME	DESIGNATION	BESHREIBUNG	DENOMINACION
	1	F000P00934	1	BARRA PROTEZIONE SINISTRA	L.H. PROTECTION	PROTECTION GAUCHE	SCHUTZ LINKS	PROTECCIÓN IZQ.
	2	F000P00935	1	BARRA PROTEZIONE DESTRA	R.H. PROTECTION	PROTECTION DROITE	SCHUTZ RECHTS	PROTECCIÓN DER.
	3	F000P01136	1	SUPPORTO BARRE	SUPPORT	SUPPORT	HALTERUNG	SOPORTE
	4	Z00062728	2	VITE TEF M6x20	FLANGED EXAGON HEAD SCREW M6x20	BOULON DE BRIDE M6x20	SCHRAUBE M6x20	TORNILLO M6x20
	5	F000P01362	2	TAPPO ROLL BAR	PLUG	BOUCHON	STOPFEN	TAPON
	6	F000P00940	1	PROTEZIONE MOTORE SINISTRA	R.H. ENGINE GUARD	PARE-MOTEUR DROITE	MOTORSCHUTZ RECHTS	PROTECCIÓN MOTOR DERECHA
	7	F000P00941	1	PROTEZIONE MOTORE DESTRA	L.H. ENGINE GUARD	PARE-MOTEUR GAUCHE	MOTORSCHUTZ LINKS	PROTECCIÓN MOTOR IZQUIERDA
	8	60ND02555	6	VITE TCEI M8x20	SCREW TCEI M8x20	VIS TCEI M8x20	SCHRAUBE TCEI M8x20	TORNILLO TCEI M8x20
	9	62ND15506	8	ROSETTA	WASHER	RONDELLE	UNTERLEGSCHLEIBE	ARANDELA
	10	F000P01586	2	PIASTRA PORTAPACCHI	BAGGAGE RACK PLATE	PLAQUE PORTE BAGAGES	PLATTE	PLACA PORTAEQUIPAJE
	11	F000P01587	1	MANIGLIA PASSEGGERO	PASSENGERS HANDLE	POIGNÉE PASSAGER	GRIFF	MANILLA ACOMPAÑANTE
	12	60ND02556	6	VITE TCEI M8x25	SCREW TCEI M8x25	VIS TCEI M8x25	SCHRAUBE TCEI M8x25	TORNILLO TCEI M8x25
	13	Z00056377	4	ROSETTA	WASHER	RONDELLE	UNTERLEGSCHLEIBE	ARANDELA
	14	F000P00938	1	PORTAPACCHI	BAGGAGE RACK	PORTE BAGAGES	HALTERUNG	PORTAEQUIPAJE
	15	800041862	4	GOMMINO ANTIVIBRANTE	SILENT-BLOCK	ANTIVIBRATION	SCHWINGUNGSDAMFER	ANTIVIBRADOR
	16	8000B2799	4	DISTANZIALE CON COLLETTO	SPACER	ENTRETOISE	ABSTANDHALTER	DISTANCIADOR
	17	60ND02510	4	VITE TCEI M6x25	SCREW TCEI M6x25	VIS TCEI M6x25	SCHRAUBE TCEI M6x25	TORNILLO TCEI M6x25
	18	F000P00768	4	RONDELLA CONICA	CONIC SPACER	RONDELLE CONIQUE	UNTERLEGSCHLEIBE	ARANDELA CONICA
	19	Z00044240	4	DADO AUTOBLOCCANTE M6	SELF-LOCKING NUT M6	ECROU AUTOBLOQUANT M6	SELBSTSICHERNDE MUTTER M6	TUERCA AUTOBLOCANTE M6
	20	F000P00939	1	PROTEZIONE MOTORE	ENGINE GUARD	PARE-MOTEUR	MOTORSCHUTZ	PROTECCIÓN MOTOR
	21	F000P01529	1	PIASTRA POSTERIORE	REAR PLATE	PLAQUE ARRIERE	PLATTE	PLACA
	22	Y00060898	4	VITE M6x15	BOLT M6x15	VIS M6x15	SCHRAUBE M6x15	TORNILLO M6x15
	23	U00046893	4	DADO A GRAFFETTA M6	CLIP NUT M6	ECROU À AGRAFE M6	SICHERUNGSMUTTER M6	TUERCA DE CLIP M6

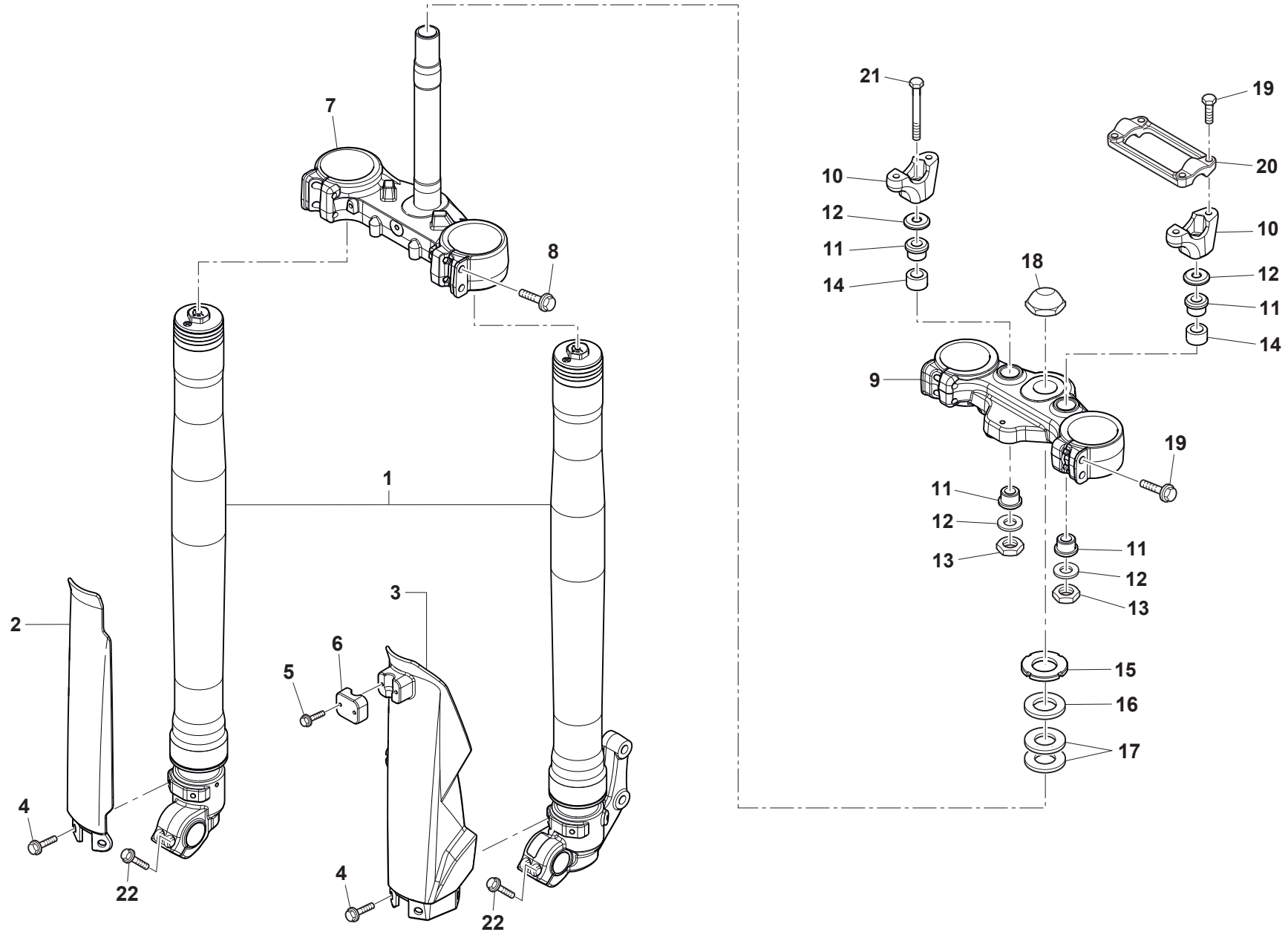



Superdual 2017

**SOSPENSIONE ANTERIORE - FRONT FORK ASSEMBLY**  
**SUSPENSION AVANT - VORDERTELESKOPGABEL**  
**SUSPENSION DELANTERA**

TAVOLA  
DRAWING  
TABLE  
BILD  
TABLA

17

Note Notes Notes Marke Notas	Pos. No. N. Index Pos.	N. Cod. Code No. Nr. Code Code Nr N. Cod.	Q.tà Q.ty Q.te M.ge C.ad	DENOMINAZIONE	NAME	DESIGNATION	BESHREIBUNG	DENOMINACION
	1	F000A01946	1	ASSIEME GAMBE FORCELLA	FORK LEGS ASSY	ENSEMBLE FOURCHE	GABELGRUPPE	GRUPO HORQUILLA
	2	F000P01012	1	PROTEZIONE SINISTRA	L.H. PROTECTION	PROTECTION GAUCHE	SCHUTZ LINKS	PROTECCIÓN IZQ.
	3	F000P01013	1	PROTEZIONE DESTRA	R.H. PROTECTION	PROTECTION DROITE	SCHUTZ RECHTS	PROTECCIÓN DER.
	4	8000A8423	6	VITE FLANGIATA M6X12	M6x12 FLANGED SCREW	VIS BRIDÉE M6x12	FLANSCHSCHRAUBE M6x12	TORNILLO CON BRIDA M6x12
	5	ZA0084658	2	VITE TEF M5X16	FLANGED EXAGON HEAD SCREW M5x16	BOULON DE BRIDE M5x16	FLANSCHENSCHRAUBE M5x16	TORNILLO DE REBORDE M5x16
	6	80F0A0633	1	FERMACAVO	CLAMP, WIRE	COLLIER, CORDON	KABELKLEMME	GRAMPA CORDON
	7	F000P01670	1	BASE DI STERZO CON PERNO	BOTTOM YOKE WITH PIN	BASE DE DIRECTION AVEC AXE	LENKLAGER MIT BOLZEN	BASE DE DIRECCIÓN CON EJE
	8	Z00062796	4	VITE TEF M6X1,25X40	SCREW TEF M6X1,25X40	VIS TEF M6X1,25X40	SCHRAUBE TEF M6X1,25X40	TORNILLO TEF M6X1,25X40
	9	F000P01671	1	TESTA DI STERZO	STEERING HEAD	TETE DE DIRECTION	LENKKOPF	CABEZAL DE DIRECCIÓN
	10	8000H2355	2	CAVALLOTTO MANUBRIO INFERIORE	HOLDER, HANDLE LOWER	BRIDE INFERIEUR GUIDON	KONSOLE, LENKER UNTEN	SOPORTE, INFERIOR MANILLAR
	11	800060233	4	SILENTBLOCK	DAMPER	SILENTBLOC	SCHWINGUNGSDAEMPFER	CASQUILLO ELASTICO
	12	800060234	4	RONDELLA 28X22X10,5X2,5 mm	WASHER 28X22X10,5X2,5 mm	RONDELLE 28X22X10,5X2,5 mm	SCHEIBE 28X22X10,5X2,5 mm	ARANDELA 28X22X10,5X2,5 mm
	13	Z00061314	2	DADO AUTOBLOCCANTE M10X1,5	NUT, SELF LOCKING M10X1,5	ECROU AUTOBLOQUANT M10X1,5	SELBSTSPERRENDE MUTTER M10X1,5	TUERCA AUTOBLOQUEANTE M10X1,5
	14	8000H3016	2	DISTANZIALE	SPACER	ENTRETOISE	ABSTANDHALTER	DISTANCIADOR
	15	8A0087717	1	GHIERA CANNOTTO STERZO	BOLT STEERING HEAD TOP	ECROU SUPERIEUR TETE DIRECTION	OBER-GEWINDE, STEUERKOPF	TUERCA SUPERIOR CABEZAL DIRECCION
	16	800087736	1	RONDELLA 40,5X29,5X2 mm	WASHER 40,5X29,5X2 mm	RONDELLE 40,5X29,5X2 mm	SCHEIBE 40,5X29,5X2 mm	ARANDELA 40,5X29,5X2 mm
	17	800087745	2	GUARNIZIONE	GASKET	GARNITURE	DICHTUNG	JUNTA
	18	F000P01004	1	DADO M26	NUT M26	ECROU M26	MUTTER M26	TUERCA M26
	19	ZC0069056	8	VITE TEF M8X1,25X30 CH12	SCREW TEF M8X1,25X30 CH12	VIS TEF M8X1,25X30 CH12	SCHRAUBE TEF M8X1,25X30 CH12	TORNILLO TEF M8X1,25X30 CH12
	20	8000B0522	1	CAVALLOTTO MANUBRIO SUPERIORE	HANDLEBAR BRACKET, UPPER	BRIDE GUIDON, SUPERIEURE	LENKER BUEGELBOLZEN, OBERE	PUNTE MANILLAR, SUPERIOR
	21	60ND01222	2	VITE TE M10X80	SCREW TE M10X80	VIS TE M10X80	SCHRAUBE TE M10X80	TORNILLO TE M10X80
	22	60ND02557	4	VITE TCEI M8X30	SCREW TCEI M8x30	VIS TCEI M8x30	SCHRAUBE TCEI M8x30	TORNILLO TCEI M8x30

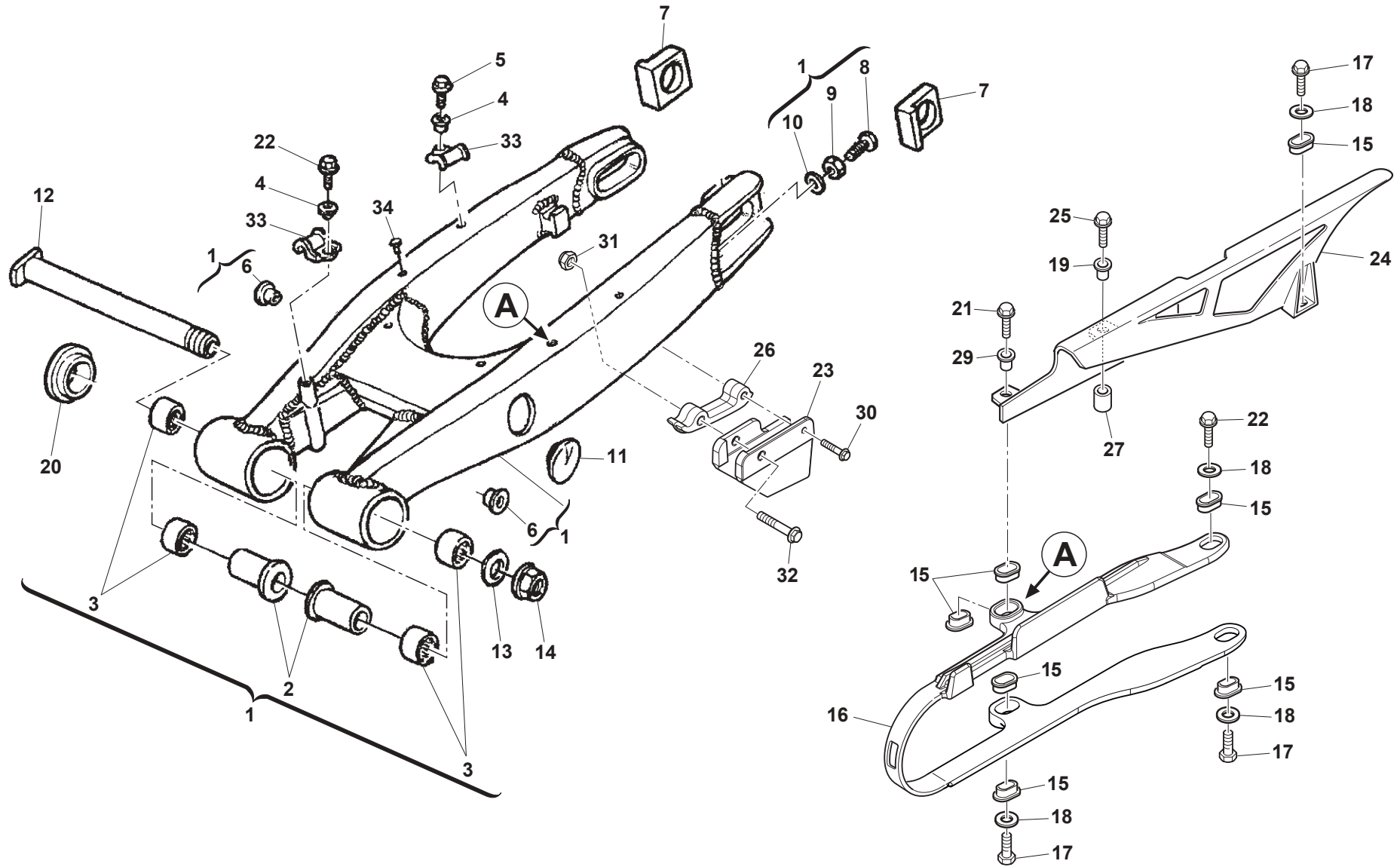

**Superdual 2017**

**FORCELLONE POSTERIORE - REAR SWING ARM  
FOURCHE ARRIERE - HINTERGABEL  
HORQUILLA TRASERA**

TAVOLA  
DRAWING  
TABLE  
BILD  
TABLA

**18**

Note Notes Notes Marke Notas	Pos. No. N. Index Pos.	N. Cod. Code No. Nr. Code Code Nr N. Cod.	Q.tà Q.ty Q.te M.ge C.ad	DENOMINAZIONE	NAME	DESIGNATION	BESHREIBUNG	DENOMINACION
	1	8000H3743	1	FORCELLONE	REAR SWING ARM ASSY	BRAS OSCILLANT	HINTERE SCHWINGE	BASCULANTE
	2	800083904	2	BOCCOLA 27,5X17X45	BUSH 27.5X17X45	DOUILLE 27,5X17X45	BUCHSE 27,5X17X45	BUJE 27,5X17X45
	3	800076283	4	GABBIA A RULLI 22X28X11	BEARING, NEEDLE 22X28X11	ROULEMENT A AIGUILLES 22X28X11	NADELAGER 22X28X11	COJINETE DE AGUJAS 22X28X11
	4	800069282	2	BOCCOLA 14X7X5,25 mm	BUSH 14X7X5.25 mm	DOUILLE 14X7X5,25 mm	BUCHSE 14X7X5,25 mm	CASQUILLO 14X7X5,25 mm
	5	Z00020536	2	VITE TE AUTOFILETTANTE 4,8X13	SCREW SELF-TAPPING 4.8X13	VIS TARAUD 4,8X13	GEWINDESCHRAUBE 4,8X13	TORNILLO AUTOROSCANTE 4,8X13
	6	8A0087810	2	BUSSOLA LATO CORONA 13 mm	BUSH, LEFT 13 mm	DOUILLE GAUCHE 13 mm	BUCHSE, LINKS 13 mm	BUJE, IZQUERDO 13 mm
	7	800096941	1	TENDICATENA SINISTRO	ADJUSTER, CHAIN LH	TENDEUR CHAINE GAUCHE	KETTENSPELLER LINKS	TENSIONADOR CADENA IZQUERDO
	7	800096944	1	TENDICATENA DESTRO	ADJUSTER, CHAIN RH	TENDEUR CHAINE DROIT	KETTENSPELLER RECHTS	TENSIONADOR CADENA DERECHO
	8	ZC0061121	2	VITE TE M8X1,25	SCREW TE M8X1.25	VIS TE M8X1,25	SCHRAUBE TE M8X1,25	TORNILLO TE M8X1,25
	9	Z00017810	2	DADO M8X1,25	NUT M8X1.25	ECROU M8X1,25	MUTTER M8X1,25	TUERCA M8X1,25
	10	Z00008536	2	RONDELLA 13X8,4X2	WASHER 13X8.4X2	RONDELLE 13X8,4X2	SCHEIBE 13X8,4X2	ARANDELA 13X8,4X2
	11	80B074388	2	TAPPO	PLUG	BOUCHON	VERSCHLUSS	TAPÓN
	12	F000P00173	1	PERNO FORCELLONE	FORK PIN	PIVOT FOURCHE	GABELBOLZEN	PERNO HORQUILLA
	13	800032388	1	RONDELLA 26X17,2X1,5	WASHER 26X17.2X1.5	RONDELLE 26X17,2X1,5	SCHEIBE 26X17,2X1,5	ARANDELA 26X17,2X1,5
	14	Z00071623	1	DADO FLANGIATO M16X1,5	NUT FLANGE M16X1.5	ECROU BRIDE M16X1,5	GEFLANSCHTE MUTTER M16X1,5	TUERCA CON REBORDE M16X1,5
	15	8000H3033	7	SCODELLINO	CUP	COUVETTE	TELLER	CUBETA
	16	8000H1320	1	PATTINO SCORRICATENA FORCELLONE	BUFFER, CHAIN TOUCH DEFENSE	PATIN PROTECTEUR BRAS OSCILLANT	KETTENGLEITFUEHRUNG	PATIN DESLIZAMIENTO CADENA
	17	Z00020536	3	VITE TE AUTOFILETTANTE 4,8X13	SCREW SELF-TAPPING 4.8X13	VIS TARAUD 4,8X13	GEWINDESCHRAUBE 4,8X13	TORNILLO AUTOROSCANTE 4,8X13
	18	Z00036137	4	RONDELLA 11X5,5X1,5	WASHER 11X5.5X1.5	RONDELLE 11X5,5X1,5	SCHEIBE 11X5,5X1,5	ARANDELA 11X5,5X1,5
	19	800097025	3	BOCCOLA	BUSHING	DOUILLE	BUCHSE	BUJE
	20	800087027	1	TAPPO PERNO FORCELLONE	CAP, PIVOT COVER	BOUCHON BRAS OSCILLANT	STOPFEN SCHWINGE	TAPON BASCULANTE
	21	ZA0067997	1	VITE TEF M5X0,8X16	SCREW TEF M5X0.8X16	VIS TEF M5X0,8X16	SCHRAUBE TEF M5X0,8X16	TORNILLO TEF M5X0,8X16
	22	Z00067997	2	VITE TEF M5X0,8X12	SCREW TEF M5X0.8 CH8	VIS TEF M5X0,8 CH8	SCHRAUBE TEF M5X0,8 CH8	TORNILLO TEF M5X0,8 CH8
	23	F000P00595	1	GUIDACATENA ESTERNO	EXTERNAL DRIVE CHAIN	GUIDE DE CHAÎNE EXTERIEURE	KETTENFÜHRUNG EXTERNER	GUÍA CADENA EXTERNO
	24	8A00A5311	1	CARTER CATENA	GUARD, CHAIN	CARTER CHAINE	KETTENGEGÄUSE	CARTER CADENA
	25	60ND01059	1	VITE TE M5X0,80X35	SCREW TE M5X0.80X35	VIS TE M5X0,80X35	SCHRAUBE TE M5X0,80X35	TORNILLO TE M5X0,80X35
	26	F000P00594	1	GUIDACATENA INTERNO	INNER DRIVE CHAIN	GUIDE DE CHAÎNE INTÉRIEUR	KETTENFÜHRUNG INNEN	GUÍA CADENA INTERNO
	27	800097025	1	BOCCOLA	BUSHING	DOUILLE	BUCHSE	BUJE
	29	8A0069282	2	DISTANZIALE 14X7X5,25 mm	SPACER 14X7X5.25 mm	ENTRETOISE 14X7X5,25 mm	ABSTANDHALTER 14X7X5,25 mm	DISTANCIADOR 14X7X5,25 mm
	30	Z00062729	2	VITE TEF M6X25	FLANGED EXAGON HEAD SCREW M6x25	BOULON DE BRIDE M6x25	FLANSCHENSCHRAUBE M6x25	TORNILLO DE REBORDE M6x25
	31	Y00043928	1	DADO M8	NUT M8	ECROU M8	MUTTER M8	TUERCA M8
	32	Z00062795	1	VITE TEF M8X50	FLANGED EXAGON HEAD SCREW M8x50	BOULON DE BRIDE M8x50	FLANSCHENSCHRAUBE M8x50	TORNILLO DE REBORDE M8x50
	33	8000B1166	2	GUIDACAVO	CABLE GUIDE	GUIDE CÂBLE	KABELFÜHRUNG	GUÍA-CABLE

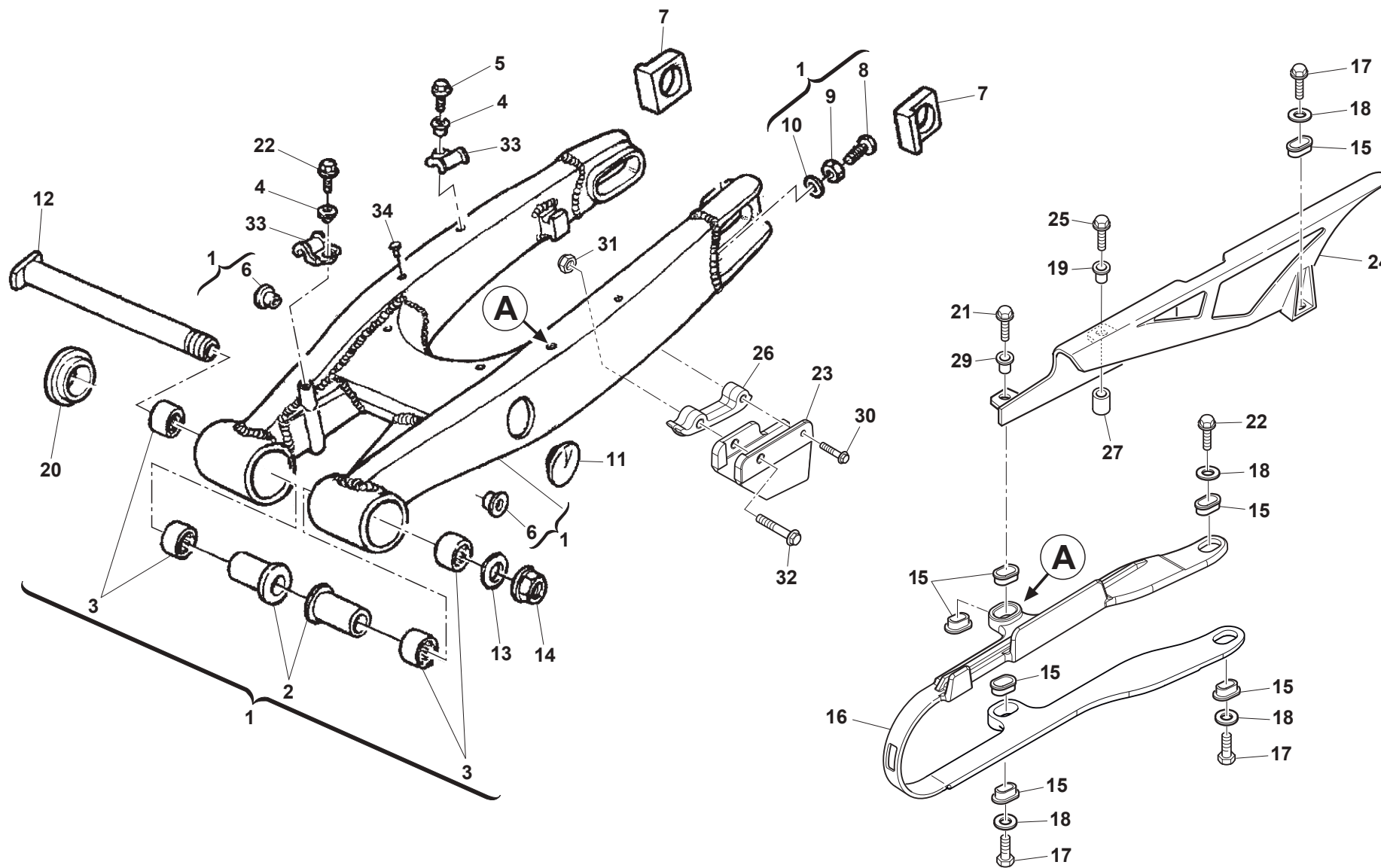



**Superdual 2017**

**FORCELLONE POSTERIORE- REAR SWING ARM-  
FOURCHE ARRIERE - HINTERGABEL  
HORQUILLA TRASERA**

TAVOLA  
DRAWING  
TABLE  
BILD  
TABLA

Note Notes Marke Notas	Pos. No. Index Pos.	N. Cod. Code No. Nr. Code Code Nr N. Cod.	Q.tà Q.ty Q.te M.ge C.ad	DENOMINAZIONE	NAME	DESIGNATION	BESHREIBUNG	DENOMINACION
	34	800075160	4	RIVETTO	RIVET	RIVET	NIET	REMACHE

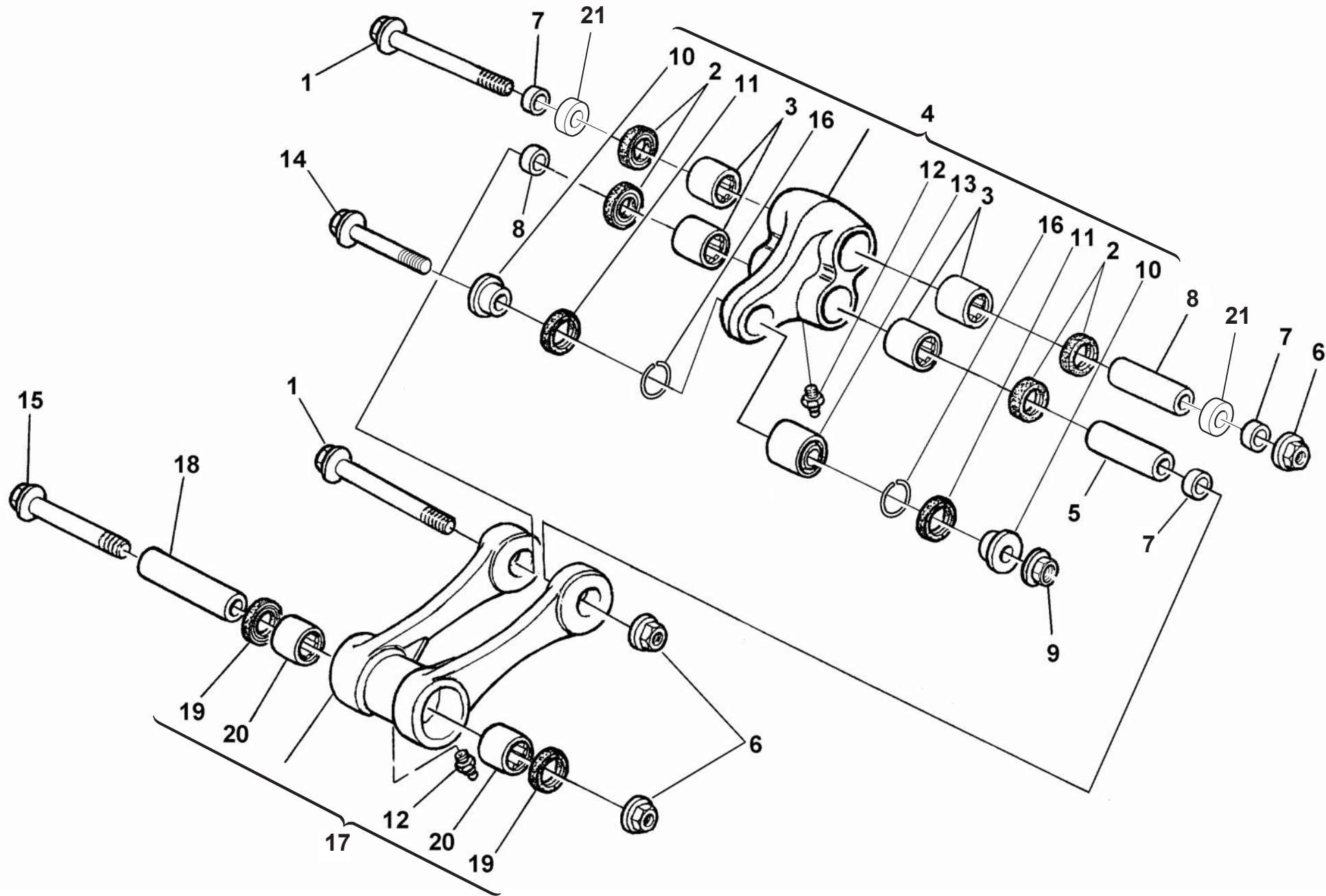





Superdual 2017

**LEVERAGGI SOSPENSIONE POSTERIORE - REAR SUSPENSION LINKAGE**  
**LEVIER SUSPENSION ARRIERE - HEBELWERK HINTERHAUFHANGUNG**  
**PALANCA SUSPENSION TRASERA**

TAVOLA  
DRAWING  
TABLE  
BILD  
TABLA

19

Note Notes Marke Notas	Pos. No. Index Pos.	N. Cod. Code No. Nr. Code Code Nr N. Cod.	Q.tà Q.ty Q.te M.ge C.ad	DENOMINAZIONE	NAME	DESIGNATION	BESHREIBUNG	DENOMINACION
	1	800093124	2	PERNO M12X1,25X103 mm	AXLE M12X1.25X103 mm	AXE M12X1,25X103 mm	ACHSE M12X1,25X103 mm	EJE M12X1,25X103 mm
	2	800086137	4	PARAOLIO 34X26X4	SEAL, OIL 34X26X4	BAGUE D'ETANCHEITE 34X26X4	WELLENDICHTRING 34X26X4	RETEN ACEITE 34X26X4
	3	800086136	4	ASTUCCIO A RULLI HK2216	BEARING, NEEDLE HK2216	ROULEMENT A AIGUILLES HK2216	NADELLAGER HK2216	COJINETE DE AGUJAS HK2216
	4	800097052	1	BILANCIERE SOSPENSIONE POSTERIORE	SWINGARM, CUSHION RELAY	CULBUTEUR SUSPENSION ARRIERE	KIPPSCHWINGE, HINTEN FEDERUNG	BRAZO SUSPENSION TRASERO
	5	800086176	1	SPINOTTO 22X15X50,4	WRIST PIN 22X15X50.4	GOUJON 22X15X50,4	BOLZEN 22X15X50,4	PASADOR 22X15X50,4
	6	Z00042023	3	DADO FLANGIATO M12X1,25	NUT FLANGE M12X1.25	ECROU BRIDE M12X1,25	GEFLANSCHTE MUTTER M12X1,25	TUERCA CON REBORDE M12X1,25
	7	8000H3015	2	BUSSOLA 26X15X5	BUSH 26X15X5	DOUILLE 26X15X5	BUCHSE 26X15X5	CASQUILLO 26X15X5
	8	8D0086176	1	SPINOTTO	GUDGEON	AXE	BOLZEN	PERNO
	9	Z00042022	1	DADO M10X1,25	NUT M10X1.25	ECROU M10X1,25	MUTTER M10X1,25	TUERCA M10X1,25
	10	151133302	2	BOCCOLA	BUSHING	DOUILLE	BUCHSE	BUJE
	11	800038767	2	PARAOLIO 26X15X4	OIL SEAL 26X15X4	BAGUE D'ETANCHEITE 26X15X4	WELLENDICHTRING 26X15X4	RETEN DE ACEITE 26X15X4
	12	800001412	2	INGRASSATORE M6X1	NIPPLE, GREASE M6X1	GRAISSEUR M6X1	SCHMIERNIPPEL M6X1	NIPLE GRASERA M6X1
	13	800072168	1	SNODO SFERICO 12X26X16	BALL JOINT 12X26X16	JOINT A ROTULE 12X26X16	KUGELGELENK 12X26X16	ROTULA ESFERICA 12X26X16
	14	ZD0062797	1	VITE TE M10X1,25X47 CH14	SCREW TE M10X1.25X47 CH14	VIS TE M10X1,25X47 CH14	SCHRAUBE TE M10X1,25X47 CH14	TORNILLO TE M10X1,25X47 CH14
	15	8B0093124	1	VITE M12X1,25X131	SCREW M12X1.25X131	VIS M12X1,25X131	SCHRAUBE M12X1,25X131	TORNILLO M12X1,25X131
	16	800090561	2	GUARNIZIONE 28X24X2	GASKET 28X24X2	JOINT 28X24X2	DICHTUNG 28X24X2	JUNTA 28X24X2
	17	8000A4428	1	BIELLA SOSPENSIONE POSTERIORE	ARM RELAY, REAR CUSHION LEVER	BIELLE SUSPENSION ARRIERE	PLEUELSTANGE HINTEN FEDERUNG	BIELA SUSPENSION TRASERA
	18	800097050	1	SPINOTTO	GUDGEON	AXE	BOLZEN	PERNO
	19	800038521	2	PARAOLIO 28X22X4	SEAL, OIL 28X22X4	BAGUE D'ETANCHEITE 28X22X4	WELLENDICHTRING 28X22X4	RETEN DE ACEITE 28X22X4
	20	8000A4427	2	ASTUCCIO A RULLI 28X 22X20	BEARING, NEEDLE 28X 22X20	CAGE A AIGUILLE 28X 22X20	NADELLAGER 28X 22X20	COJINETE DE AGUJAS 28X 22X20
	21	8A0086177	2	DISTANZIALE	SPACER	ENTRETOISE	ABSTANDHALTER	DISTANCIADOR

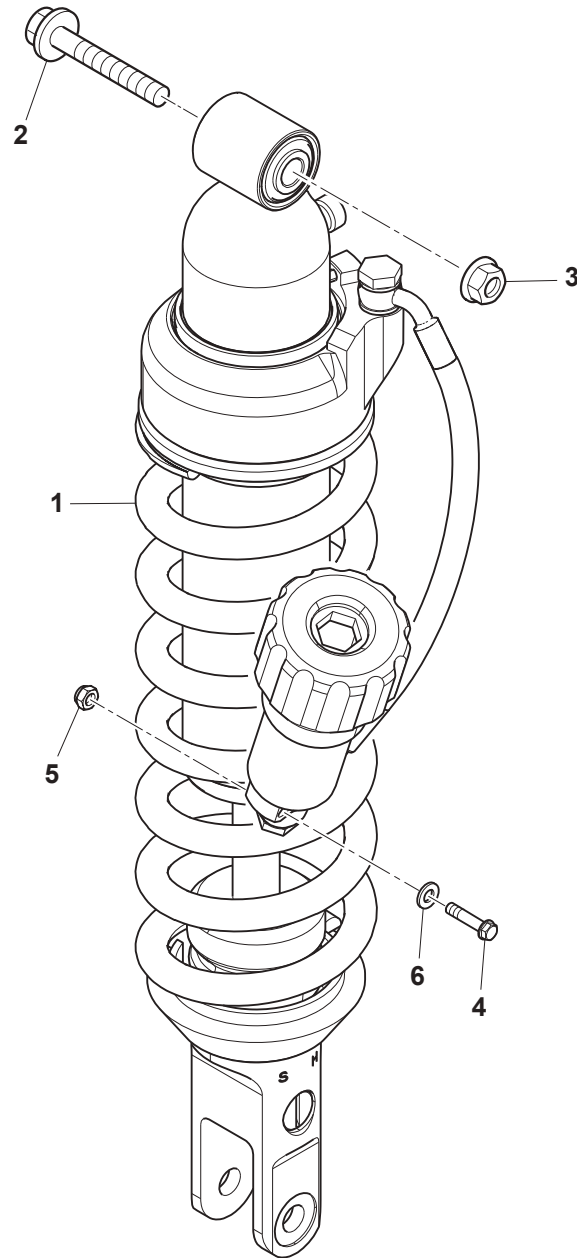



Superdual 2017

**AMMORTIZZATORE POSTERIORE- REAR SUSPENSION  
SUSPENSION ARRIERE- HINTERHAUFHANGUNG  
SUSPENSION TRASERA**

TAVOLA  
DRAWING  
TABLE  
BILD  
TABLA

20

Note Notes Marke Notas	Pos. No. Index Pos.	N. Cod. Code No. Nr. Code Code Nr N. Cod.	Q.tà Q.ty Q.te M.ge C.ad	DENOMINAZIONE	NAME	DESIGNATION	BESHREIBUNG	DENOMINACION
	1	F000A01059	1	AMMORTIZZATORE POSTERIORE	REAR SHOCK ABSORBER	AMORTISSEUR ARRIÈRE COMPLET	STOßDÄMPFER KOMPLETT	AMORTIGUADOR COMPLETO
	2	ZD0062797	1	VITE TE M10X1,25X47 CH14	SCREW TE M10X1.25X47 CH14	VIS TE M10X1,25X47 CH14	SCHRAUBE TE M10X1,25X47 CH14	TORNILLO TE M10X1,25X47 CH14
	3	Z00042022	1	DADO M10X1,25	NUT M10X1.25	ECROU M10X1,25	MUTTER M10X1,25	TUERCA M10X1,25
	4	Z00062730	2	VITE TEF M6X30	FLANGED EXAGON HEAD SCREW M6x30	BOULON DE BRIDE M6x30	SCHRAUBE M6x30	TORNILLO M6x30
	5	Z00044240	2	DADO	NUT	ECROU	MUTTER	TUERCA
	6	62NDI5506	2	ROSETTA	WASHER	RONDELLE	UNTERLEGSCHIEBE	ARANDELA

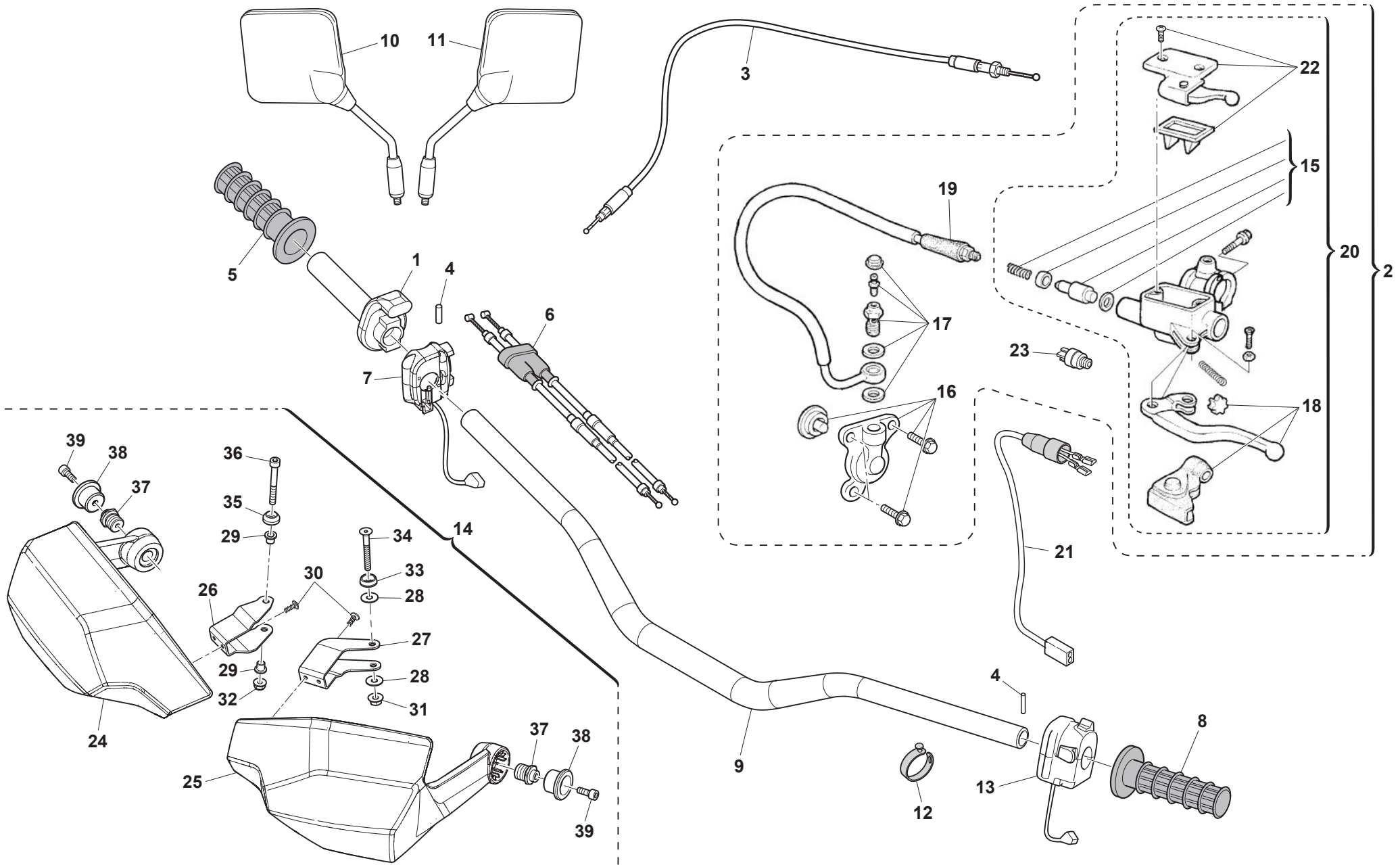



**MANUBRIO E COMANDI - HANDLEBAR AND CONTROLS  
GUIDON ET COMMANDES - LENKER UND STEUERORGANE  
MANILLAR Y MANDOS**

Note Notes Notes Marke Notas	Pos. No. N. Index Pos.	N. Cod. Code No. Nr. Code Code Nr N. Cod.	Q.tà Q.ty Q.te M.ge C.ad	DENOMINAZIONE	NAME	DESIGNATION	BESHREIBUNG	DENOMINACION
	1	8000H6477	1	COMANDO GAS	GRIP, THROTTLE	COMMANDE GAZ	GASSCHALTUNG	MANDO ACELERADOR
	2	F000A00036	1	IMPIANTO COMANDO FRIZIONE	CLUTCH CONTROL SYSTEM	SYSTEME COMMANDE EMBRAYAGE	KUPPLUNGSHEBELSCHALTUNGANLAGE	SISTEMA MANDO EMBRAGUE
	3	8000H1545	1	CAVO STARTER	CABLE, STARTER	CABLE COMMANDE STARTER	STARTERKABEL	CABLE STARTER
	4	8000A1074	2	PIOLO	HOB	BARREAU	PFLOCK	CLAVIJA
	5	F000P00943	1	MANOPOLA DESTRA	RH HANDGRIP	POIGNÉE DROITE	GRIFF RECHTS	PUÑO DERECHA
	6	8000H2115	1	CAVO GAS	CABLE, THROTTLE	CABLE GAZ	GASSEIL	CABLE ACELERADOR
	7	8000H1174	1	COMMUTATORE LUCI DESTRO	HANDLE SWITCH, RH	COMMUTATEUR FEUX DROITE	RECHTER LICHTSCHALTER	CONMUTADOR LUCES DERECHO
	8	F000P00944	1	MANOPOLA SINISTRA	L.H. HANDGRIP	POIGNÉE GAUCHE	GRIFF LINKS	PUÑO IZQUIERDA
	9	F000P01543	1	MANUBRIO	HANDLEBAR	GUIDON	LENKER	MANILLAR
	10	8A00H1673	1	SPECCHIO DESTRO	MIRROR, RH	MIROIR DROIT	SPIEGEL RECHTS	ESPEJO DERECHO
	11	8000H1673	1	SPECCHIO SINISTRO	MIRROR, LEFT	MIROIR GAUCHE	SPIEGEL LINKS	ESPEJO IZQUERDO
	12	800050005	1	FASCETTA	CLAMP	COLLIER	KLAMMER	ABRAZADERA
	13	8000H1173	1	COMMUTATORE LUCI SINISTRO	HANDLE SWITCH, LEFT	COMMUTATEUR FEUX GAUCHE	LINKER LENKERSCHALTER	CONMUTADOR LUCES IZQUERDO
	14	A000A00929	1	KIT PARAMANI	HAND GUARD KIT	KIT DE PROTECTION MAINS	HANDSCHUT-KIT	KIT PROTECTOR MANOS
	15	F000A00797	1	KIT PISTONCINO POMPA FRIZIONE	"CYLINDER KIT, MASTER"	"KIT PISTON POMPE"	KOLBEN, PUMPE KIT	KITPISTON BOMBA
	16	F000A00798	1	SPINGIFRIZIONE IDRAULICO	CYLINDER, CLUTCH PRESSURE	"CYLINDRE POUSSEE EMBRAYAGE"	KUPPLUNGSZYLINDERDRUCH	"CILINDRO EMPUJADOR EMBRAGUE"
	17	F000A00799	1	VITE SPURGO	SCREW, BLEED	VIS VIDANGE	SCHRAUBE, ABLASS	"TORNILLO PURGA"
	18	F000A00800	1	KIT LEVA FRIZIONE	CLUTCH LEVER KIT	KIT LEVIER EMBRAYAGE	"KUPPLUNGSHEBEL KIT"	KIT PALANCA EMBRAGUE
	19	F000P00801	1	TUBO OLIO FRIZIONE	HOSE, CLUTCH OIL	TUYAU HUILE EMBRAYAGE	KUPPLUNGSSTEUERUNGSSCHLAUCH	TUBO MANDO EMBRAGUE
	20	F000A00802	1	POMPA FRIZIONE	CLUTCH MASTER CYLINDER	MAITRE-CYLINDRE EMBRAYAGE	KUPPLUNGSHAUPTZYLINDER	"BOMBA EMBRAGUE"
	21	800075477	1	CAVO MICROINTERRUPTORE	MICROSWITCH CABLE	CABLAGE MICROINTERRUPTEUR	VERKABELUNG MIKROSCHALTER	CABLEADO MICROINTERRUPTOR
	22	F000A00805	1	KIT COPERCHIO POMPA FRIZIONE	CLUTCH PUMP COVER KIT	KIT COUVERCLE MAITRE-CYLINDRE	DECKEL PUMPE KIT	KIT TAPA BOMBA
	23	F000P00804	1	MICROINTERRUPTORE	MICROSWITCH	MICROINTERRUPTEUR	MIKROSCHALTER	MICROINTERRUPTOR
	24	F000P01415	1	PARAMANO DESTRO	R.H. HANDGUARD	PROTECTION MAIN DROITE	HANDSCHUTZ RECHTS	PROTECCIÓN MANO DERECHO
	25	F000P01416	1	PARAMANO SINISTRO	L.H. HANDGUARD	PROTECTION MAIN GAUCHE	HANDSCHUTZ LINKS	PROTECCIÓN MANO IZQUIERDO
	26	F000P01467	1	SUPPORTO DESTRO	R.H. SUPPORT	SUPPORT DROITE	HALTERUNG RECHTS	SOPORTE DERECHO
	27	F000P01468	1	SUPPORTO SINISTRO	L.H. SUPPORT	SUPPORT GAUCHE	HALTERUNG LINKS	SOPORTE IZQUIERDO
	28	62ND15548	2	ROSETTA	WASHER	RONDELLE	UNTERLEGSSCHEIBE	ARANDELA
	29	8000H0822	2	BUSSOLA CON COLLETTA	BUSHING	DOUILLE	BUCHSE	CASQUILLO
	30	F000P01535	4	VITE AUTOFILETTANTE M4x10	SCREW, TAPPING M4x10	VIS TARAUD M4x10	GEWINDESCHRAUBE M4x10	TORNILLO AUTOROSCANTE M4x10
	31	61ND15192	1	DADO	NUT	ECROU	MUTTER	TUERCA
	32	Z00044240	1	DADO AUTOBLOCCANTE	SELF-LOCKING NUT	ECROU AUTOBLOQUANT	SELBSTSICHERNDE MUTTER	TUERCA AUTOBLOCANTE
	33	F000P01536	1	BUSSOLA CONICA	CONIC BUSHING	DOUILLE CONIQUE	UNTERLEGBUCHSE	CASQUILLO CONICO

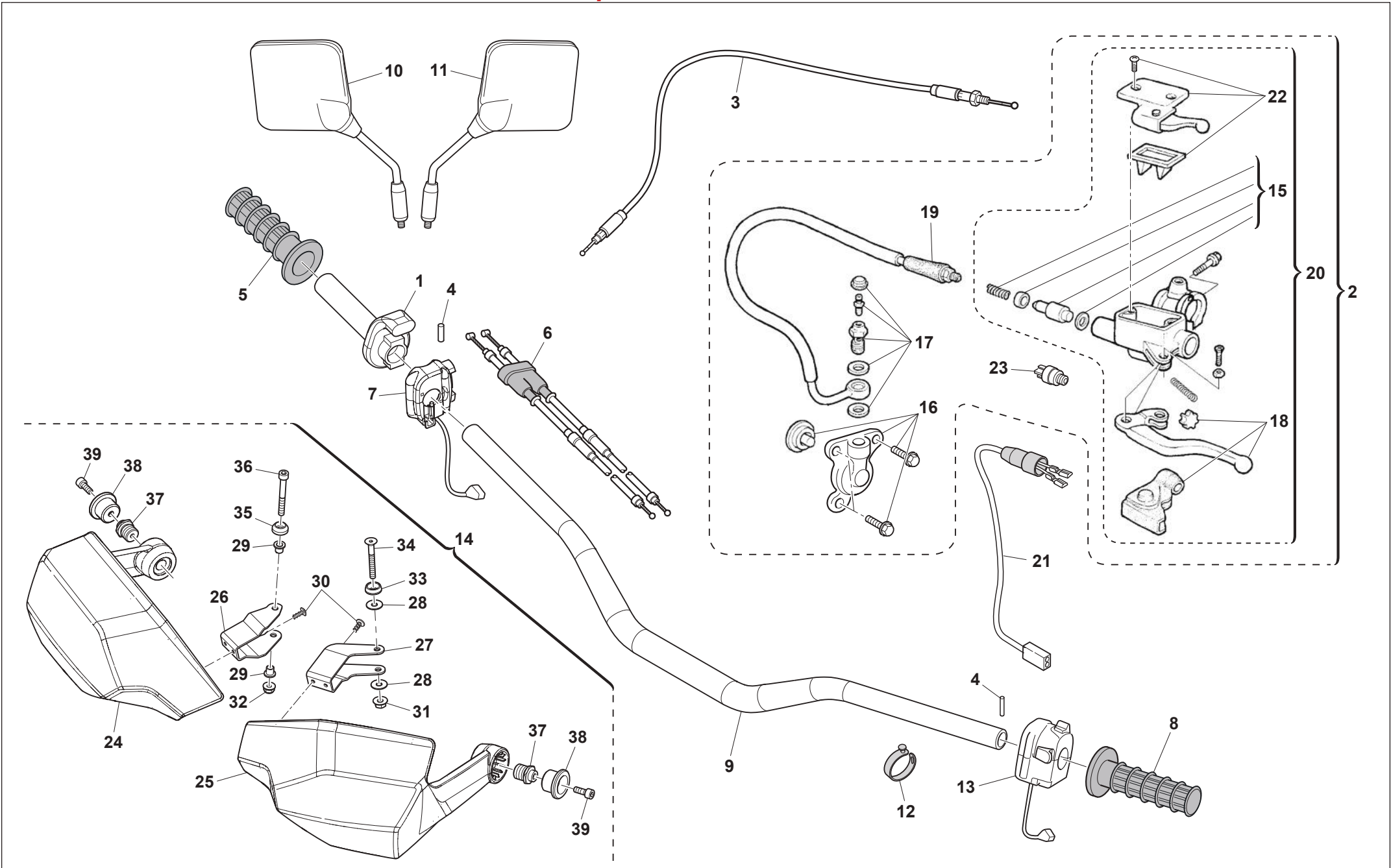



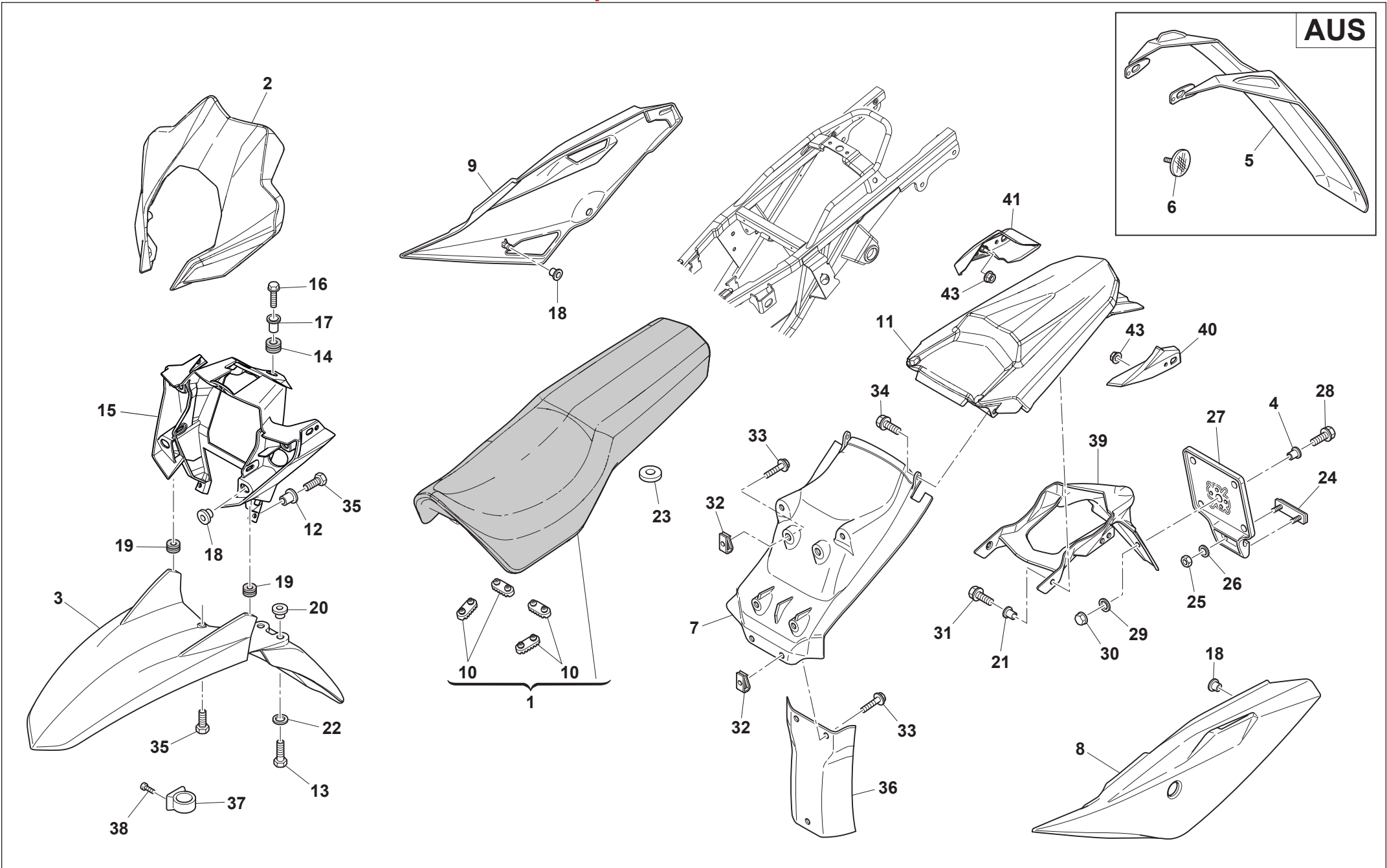





Superdual 2017

**PANNELLI, PARAFANGHI, SELLA - PANEL, FENDERS, SEAT  
 PANNEAU, GARDE-BOUES, SIEGE - STREIFEN, KOTFLUGEL, SATTEL  
 PANELO, GUARDABARROS, SILLIN**

TAVOLA  
 DRAWING  
 TABLE  
 BILD  
 TABLA

22

Note Notes Notes Marke Notas	Pos. No. N. Index Pos.	N. Cod. Code No. Nr. Code Code Nr N. Cod.	Q.tà Q.ty Q.te M.ge C.ad	DENOMINAZIONE	NAME	DESIGNATION	BESHREIBUNG	DENOMINACION
	1	F000A00996	1	SELLA	SADDLE	SELLE	SITZBANK	ASIENTO
	2	F000A01010	1	CUPOLINO	FRONT FAIRING	NEZ DE CARÉNAGE	WINDSCHUTZSCHEIBE	CÚPULA
	3	80E0A4711	1	PARAFANGO ANTERIORE	FRONT MUDGUARD	GARDE-BOUE AVANT	VORDERRADKOTFLÜGEL	GUARDABARROS DELANTERO
	4	800069282	2	BOCCOLA 14X7X5,25 mm	BUSH 14X7X5.25 mm	DOUILLE 14X7X5,25 mm	BUCHSE 14X7X5,25 mm	CASQUILLO 14X7X5,25 mm
	5	8000H1518	1	PROLUNGA PARAFANGO POSTERIORE	EXTENTION, REAR FENDER	BAVETTE GARDE-BOUE ARRIERE	KOTSCHUTZKLAPPEN, HINTEN	PROLONGACION GUARDABARROS TRASERO
AUS	6	800074842	2	CATADIOTTRO	REFLEX REFLECTOR	CATADIOPTRE	RUECKSTRAHLER	CATAFARO
	7	8000H1268	1	PARAFANGO POSTERIORE INTERNO	INTERNAL REAR MUDGUARD	GARDE-BOUE ARRIÈRE	HINT. KOTFLUEGEL	GUARDA-BARROS TRASERO
	8	F000P01096	1	FIANCHETTO SINISTRO	COVER, FRAME L.H.	COUVERCLE CADRE GAUCHE	SEITENDECKEL, LINKS	CUBIERTA BASTIDOR IZQUERDA
	9	F000P01097	1	FIANCHETTO DESTRO	COVER, FRAME R.H.	COUVERCLE CADRE DROIT	SEITENDECKEL, RECHTS	CUBIERTA BASTIDOR DERECHA
	10	86610191A	4	TAMPONE IN GOMMA	CUSHION RUBBER	TAMPON EN CAOUTCHOUC	GUMMISTOPFEN	TAMPON GOMA
	11	F000P01011	1	PARAFANGO POSTERIORE	REAR MUDGUARD	GARDE-BOUE ARRIÈRE	HINTERRADKOTFLÜGEL	GUARDABARROS TRASERO
	12	800069235	2	DISTANZIALE 16X9,5X6,5	SPACER 16X9,5X6,5	ENTRETOISE 16X9,5X6,5	ABSTANDHALTER 16X9,5X6,5	DISTANCIADOR 16X9,5X6,5
	13	Z00062728	4	VITE TE M6X1X16 CH8	SCREW TE M6X1X16 CH8	VIS TE M6X1X16 CH8	SCHRAUBE TE M6X1X16 CH8	TORNILLO TE M6X1X16 CH8
	14	8000H3250	4	GOMMINO	SILENT-BLOCK	ANTIVIBRATION	SCHWINGUNGSDÄMPFER	ANTI-VIBRADOR
	15	8000H1275	1	SUPPORTO FANALE ANTERIORE	STAY, HEADLIGHT	SUPPORT FEU AVANT	KONSOLE, SCHEINWERFER	SOPORTE FARO DELANTERO
	16	8A00A8423	2	VITE FLANGIATA M6X12	BOLT, FLANGE M5X12	VIS A EMBASE M5X12	GEFLANSCHSCHRAUBE M5X12	TORNILLO CON VALONA M5X12
	17	8000H3251	1	BOCCOLA	BUSHING	DOUILLE	BUCHSE	BUJE
	18	800041874	6	GOMMINO 24X13X9	GROMMET 24X13X9	CAOUTCHOUC 24X13X9	GUMMITEILE 24X13X9	GOMA 24X13X9
	19	800095128	2	GOMMINO	SILENT-BLOCK	ANTIVIBRATION	SCHWINGUNGSDÄMPFER	ANTI-VIBRADOR
	20	Z00069429	6	BOCCOLA 9X7X4,8	BUSH 9X7X4.8	DOUILLE 9X7X4,8	BUCHSE 9X7X4,8	BUJE 9X7X4,8
	21	8CA0H3017	4	BOCCOLA	BUSHING	DOUILLE	BUCHSE	CASQUILLO
	22	Z00048814	4	RONDELLA 18X6,4X2	WASHER 18X6.4X2	RONDELLE 18X6,4X2	SCHEIBE 18X6,4X2	ARANDELA 18X6,4X2
	23	8A00H2959	1	RONDELLA IN GOMMA	WASHER, RUBBER	RONDELLE EN CAOUTCHOUC	GUMMISCHEIBE	ARANDELA GOMA
	24	800073834	1	CATADIOTTRO POSTERIORE	REFLEX REFLECTOR, REAR	CATADIOPTRE ARRIERE	RUECKSTRAHLER	CATAFARO TRASERO
	25	Z00040717	1	DADO FLANGIATO M4X0,7	FLANGED NUT M4X0,7	ECROU BRIDE M4X0,7	FLANSCHMUTTER M4X0,7	TUERCA CON BRIDA M4X0,7
	26	62ND15547	2	RONDELLA	WASHER	RONDELLE	UNTERLEGSCHIEBE	ARANDELA
	27	8000H3018	1	PIASTRA PORTATARGA	BRACKET, LICENSE PLATE	PORTE-PLAQUE IMMATRICULATION	KONSOLE, KENNZEICHEN	PORTA-MATRICULA
	28	Z00067997	2	VITE TEF M5X0,8X12	SCREW TEF M5X0.8 CH8	VIS TEF M5X0,8 CH8	SCHRAUBE TEF M5X0,8 CH8	TORNILLO TEF M5X0,8 CH8
	29	62ND15547	2	RONDELLA	WASHER	RONDELLE	SCHEIBE	ARANDELA
	30	Z00040717	2	DADO FLANGIATO M4X0,7	NUT FLANGE M4X0.7	ECROU BRIDE M4X0,7	GEFLANSCHTE MUTTER M4X0,7	TUERCA CON REBORDE M4X0,7
	31	8A00A8423	3	VITE FLANGIATA M6X12	BOLT, FLANGE M5X12	VIS A EMBASE M5X12	GEFLANSCHSCHRAUBE M5X12	TORNILLO CON VALONA M5X12
	32	U00046893	6	DADO ELASTICO M6X1	CLIP NUT M6X1	JONC M6X1	KLEMME M6X1	PREASIENTO M6X1
	33	8A00A8423	6	VITE FLANGIATA M6X12	BOLT, FLANGE M6X12	VIS A EMBASE M6X12	GEFLANSCHSCHRAUBE M6X12	TORNILLO CON VALONA M6X12

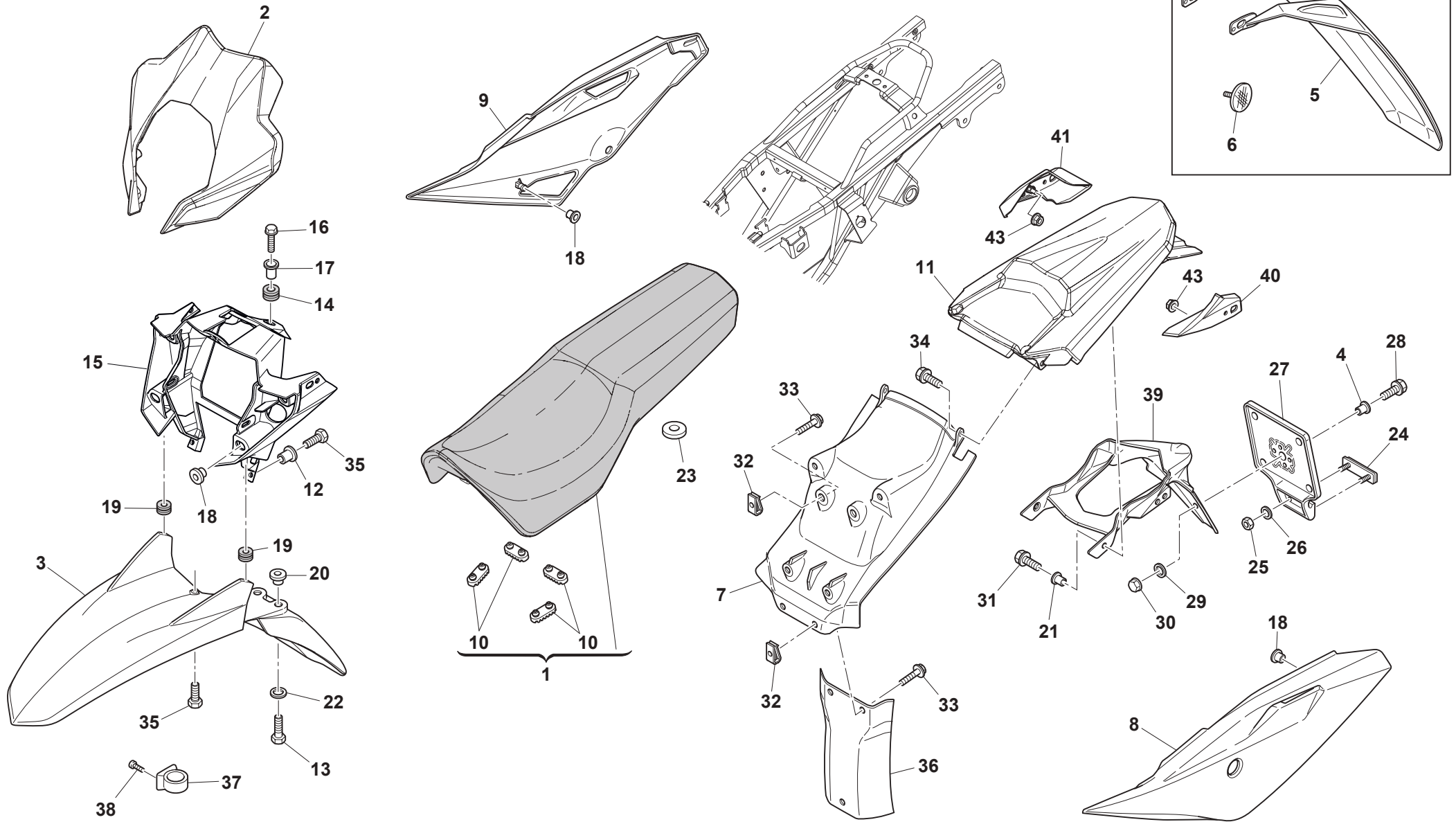



PANNELLI, PARAFANGHI, SELLA - PANEL, FENDERS, SEAT  
 PANNEAU, GARDE-BOUES, SIEGE - STREIFEN, KOTFLUGEL, SATTEL  
 PANELO, GUARDABARROS, SILLIN

Note Notes Notes Marke Notas	Pos. No. N. Index Pos.	N. Cod. Code No. Nr. Code Code Nr N. Cod.	Q.tà Q.ty Q.te M.ge C.ad	DENOMINAZIONE	NAME	DESIGNATION	BESHREIBUNG	DENOMINACION
	34	Z00062727	2	VITE FLANGIATA M6X16	BOLT, FLANGE M6X16	VIS A EMBASE M6X16	GEFLANSCHSCHRAUBE M6X16	TORNILLO CON VALONA M6X16
	35	Z00062728	6	VITE TEF M6X1X20 CH8	SCREW TEF M6X1X20 CH8	VIS TEF M6X1X20 CH8	SCHRAUBE TEF M6X1X20 CH8	TORNILLO TEF M6X1X20 CH8
	36	800069551	1	PROTEZIONE AMMORTIZZATORE	GUARD	PROTECTION	SCHUTZ	PROTECCIÓN
	37	8000A0864	2	GUIDA TUBO FRENO ANTERIORE	GUIDE, FRONT BRAKE HOSE	GUIDE TUYAU FREIN AVANT	BREMSSCHLAUCH VORNEFUEHRUNG	GUIA MANGUERA FRENO DELANTERO
	38	ZA0037283	2	VITE AUTOFILETTANTE AB 3,5X9,5	SCREW SELF-TAPPING AB 3.5X9.5	VIS TARAUD AB 3,5X9,5	GEWINDESCHRAUBE AB 3,5X9,5	TORNILLO AUTOROSCANTE AB 3,5X9,5
	39	8A00H1405	1	PARAFANGO POSTERIORE PORTATARGA	FENDER, REAR NUMBER PLATE HOLDER	GARDE-BOUE ARRIERE PORTE-PLAQUE	KOTFLUEGEL HINTEN KENNZEICHEN	GUARDABARROS TRAS. PORTA-MATRICULA
	40	F000P01552	1	SUPPORTO INDICATORE DIREZIONE SX	RH TURN INDICATOR SUPPORT	SUPPORT CLIGNOTANT D	HALTERUNG RE	SOPORTE INTERMITENTE CDH.
	41	FA00P01552	1	SUPPORTO INDICATORE DIREZIONE DX	LH TURN INDICATOR SUPPORT	SUPPORT CLIGNOTANT G	HALTERUNG LI	SOPORTE INTERMITENTE IZQ.
	42	Z00044240	2	DADO FLANGIATO M6	FLANGED NUT M6	ECROU BRIDE M6	FLANSCHMUTTER M6	TUERCA CON BRIDA M6

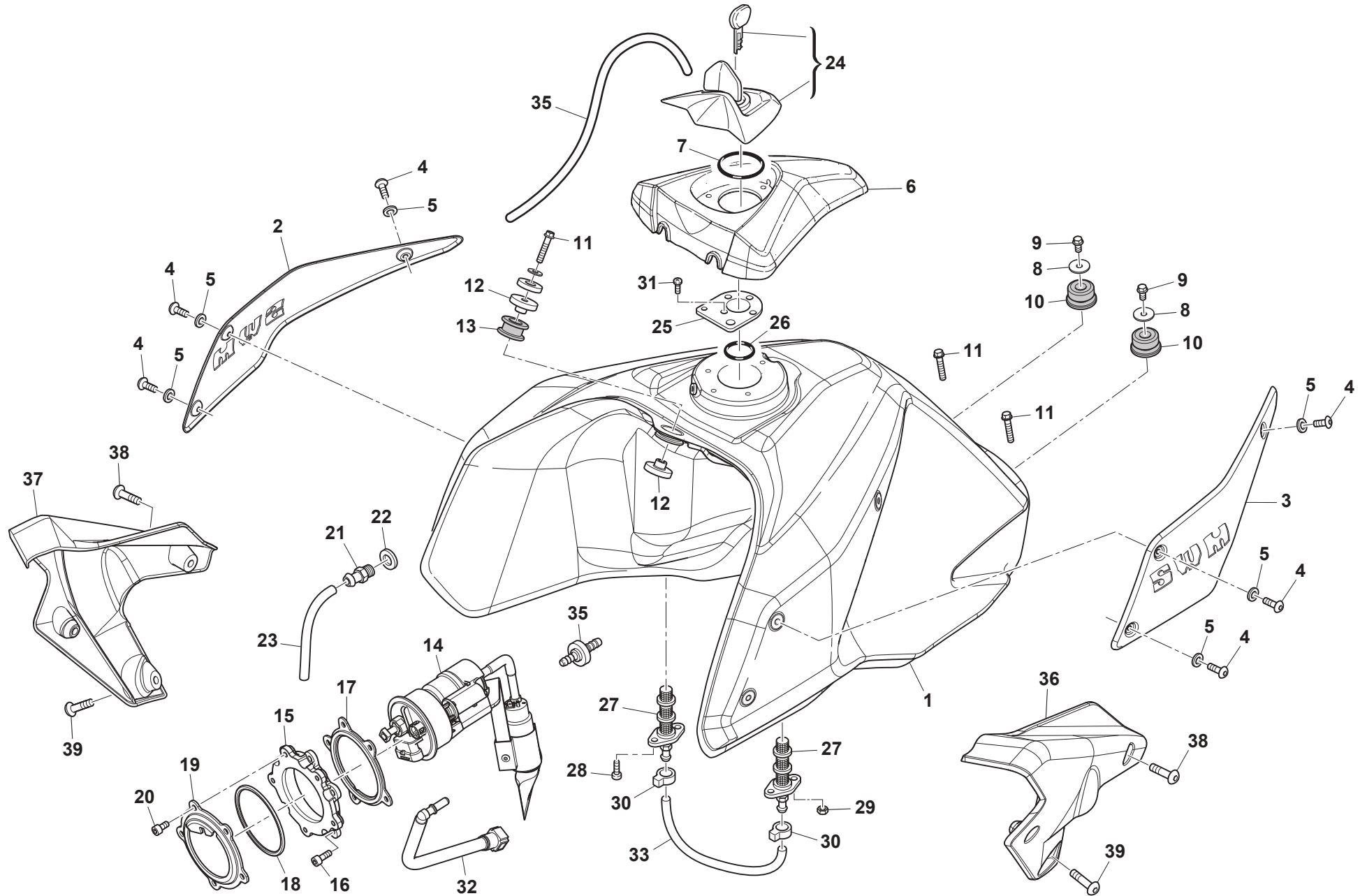



**SERBATOIO CARBURANTE, CONVOGLIATORI - GAS TANK, PANEL -  
RESERVOIR CARBURANT, FLANC - KRAFTSTOFFBEHALTER, FLANKE -  
DEPOSITO GASOLINA, LATERAL**

Note Notes Notes Marke Notas	Pos. No. N. Index Pos.	N. Cod. Code No. Nr. Code Code Nr N. Cod.	Q.tà Q.ty Q.te M.ge C.ad	DENOMINAZIONE	NAME	DESIGNATION	BESHREIBUNG	DENOMINACION
	1	F000P00954	1	SERBATOIO CARBURANTE	FUEL TANK	RÉSERVOIR DE CARBURANT	KRAFTSTOFFTANK	DEPÓSITO COMBUSTIBLE
	2	F000P01020	1	PLACCA DESTRA	R.H. PLATE	PLAQUE DROIT	PLATTE RECHTS	PLACA DERECHA
	3	F000P01021	1	PLACCA SINISTRA	L.H. PLATE	PLAQUE GAUCHE	PLATTE LINKE	PLACA IZQUIERDA
	4	ZA0059572	6	VITE M5x12	BOLT M5x12	VIS M5x12	SCHRAUBE M5x12	TORNILLO M5x12
	5	800035112	6	ROSETTA	WASHER	RONDELLE	UNTERLEGSCHIEBE	ARANDELA
	6	F000P01154	1	COPERCHIETTO	COVER	COUVERCLE	DECKEL	TAPA
	7	F000P01576	1	ANELLO OR	O-RING	JOINT TORIQUE	O-RING	JUNTA TORICA
	8	Z00059801	2	ROSETTA	WASHER	RONDELLE	UNTERLEGSCHIEBE	ARANDELA
	9	ZH0067545	2	VITE M6x12	SCREW M6x12	VIS M6x12	SCHRAUBE M6x12	TORNILLO M6x12
	10	F000P01570	2	ANTIVIBRANTE	SILENT-BLOCK	ANTIVIBRATION	SCHWINGUNGSDAMFER	ANTIVIBRADOR
	11	8A00B1959	4	VITE TEF M8x30	FLANGED EXAGON HEAD SCREW M8x30	BOULON DE BRIDE M8x30	FLANSCHENSCHRAUBE M8x30	TORNILLO DE REBORDE M8x30
	12	F000P02163	2	BUSSOLA	BUSHING	DOUILLE	BUCHSE	CASQUILLO
	13	800089302	1	ANTIVIBRANTE	SILENT-BLOCK	ANTIVIBRATION	SCHWINGUNGSDAMFER	ANTIVIBRADOR
	14	F000P01414	1	POMPA BENZINA	FUEL PUMP	POMPE À CARBURANT	BENZINPUMPE	BOMBA GASOLINA
	15	F000P01230	1	FLANGIA POMPA	FLANGE	BRIDE	FLANSCH	BRIDA
	16	60ND07335	5	VITE TCEI M6x16	SCREW TCEI M6x16	VIS TCEI M6x16	SCHRAUBE TCEI M6x16	TORNILLO TCEI M6x16
	17	F000P02488	1	GUARNIZIONE	GASKET	JOINT	DICHTUNG	JUNTA
	18	8C00H1186	1	GUARNIZIONE POMPA BENZINA	FUEL PUMP GASKET	JOINT POMPE DE CARBURANT	DICHTUNG PUMPE	JUNTA BOMBA COMBUSTIBLE
	19	F000P01377	1	FLANGIA 5 FORI	FLANGE	BRIDE	FLANSCH	BRIDA
	20	60ND02505	5	VITE TCEI M6x12	SCREW TCEI M6x12	VIS TCEI M6x12	SCHRAUBE TCEI M6x12	TORNILLO TCEI M6x12
	21	8000A4031	1	RACCORDO FILETTATO	THREADED CONNECTOR	RACCORD FILETÉ	GEWINDEANSCHLUSS	RACOR ROSCADO
	22	62N015673	1	ROSETTA IN ALLUMINIO	WASHER	RONDELLE	UNTERLEGSCHIEBE	ARANDELA
	23	F000P02214	1	TUBO L= 340 mm	PIPE L= 340 mm	TUBE L= 340 mm	ROHR L= 340 mm	TUBO L= 340 mm
	24	F000A00193	1	TAPPO SERBATOIO CARBURANTE	FUEL TANK PLUG	BOUCHON RÉSERVOIR	STOPFEN	TAPON
	25	8000A7409	1	FLANGIA TAPPO SERBATOIO	FUEL CAP FLANGE	BRIDE BOUCHON CARBURANT	FLANSCH TANKDECKEL	BRIDA TAPON COMBUSTIBLE
	26	8A00A9701	1	ANELLO DI TENUTA	SEALING RING	BAGUE D'ETANCHEITE	DICHTUNGSRING	ANILLO DE ESTANQUEIDAD
	27	F000A01424	2	RUBINETTO COMPLETO	COCK ASSY	ROBINET COMPLET	HAHN KOMPLETT	LLAVE COMPLETA
	28	60ND07335	2	VITE TCEI M6x16	SCREW TCEI M6x16	VIS TCEI M6x16	SCHRAUBE TCEI M6x16	TORNILLO TCEI M6x16
	29	Z00044240	2	DADO AUTOBLOCCANTE M6	SELF-LOCKING NUT M6	ECROU AUTOBLOQUANT M6	SELBSTSICHERNDE MUTTER M6	TUERCA AUTOBLOCANTE M6
	30	8E0095276	2	FASCETTA STRINGITUBO	METALLIC CLIP	COLLIERT	SHELLE	ABRAZADERA
	31	Z00065535	4	VITE TCEI M5x14	SCREW TCEI M5x14	VIS TCEI M5x14	SCHRAUBE TCEI M5x14	TORNILLO TCEI M5x14
	32	F000P01575	1	TUBO MANDATA BENZINA	DELIVERY PIPE	TUYAU DE REFOULEMENT	VORLAUFROHR	TUBO ALIMENTACIÓN
	33	8E0094010	1	TUBO L= 280mm	PIPE L= 280mm	TUBE L= 280mm	ROHR L= 280mm	TUBO L= 280mm

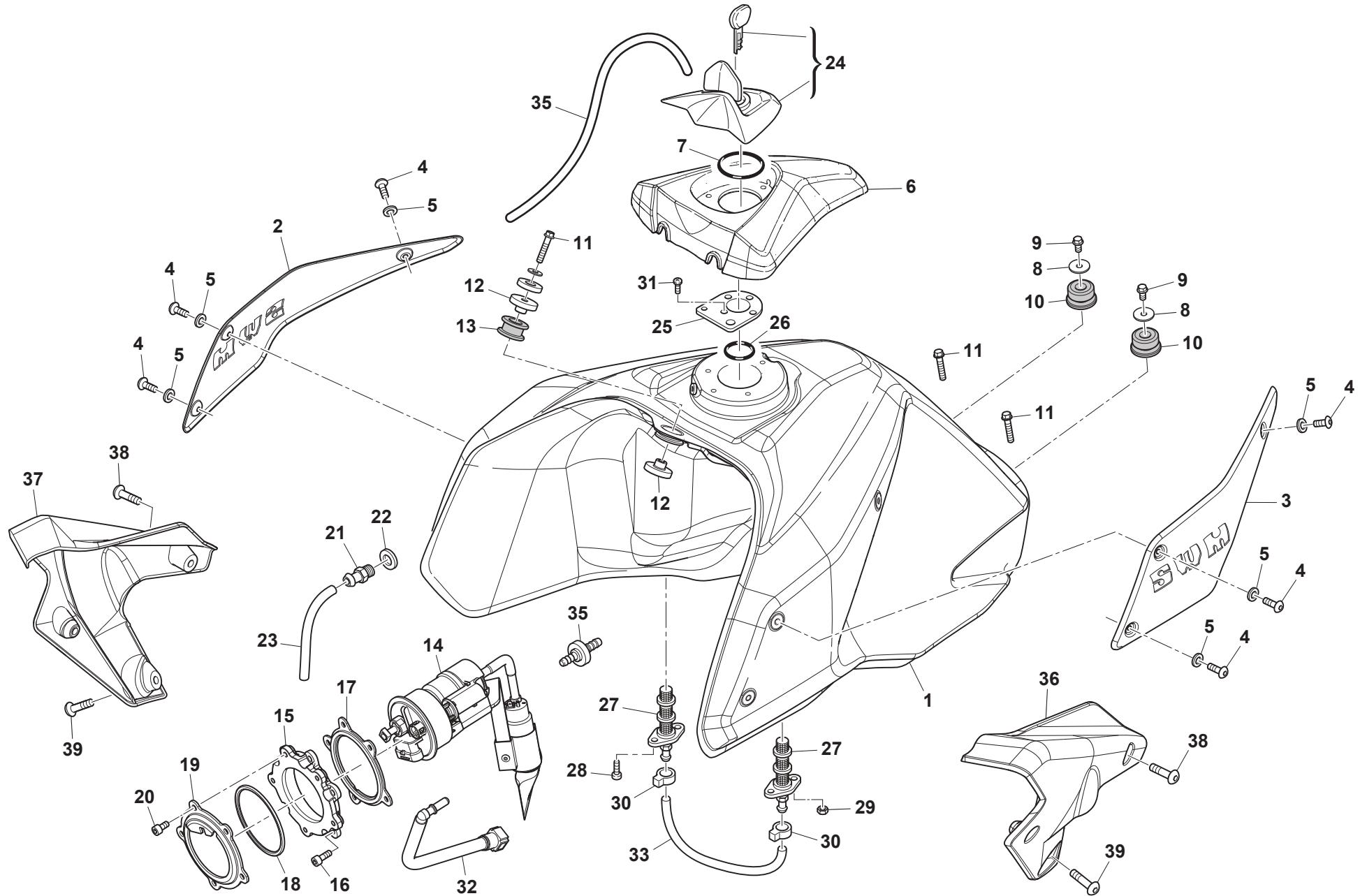



Superdual 2017

SERBATOIO CARBURANTE, CONVOGLIATORI - GAS TANK, PANEL -  
 RESERVOIR CARBURANT, FLANC - KRAFTSTOFFBEHALTER, FLANKE -  
 DEPOSITO GASOLINA, LATERAL

TAVOLA  
 DRAWING  
 TABLE  
 BILD  
 TABLA

23

Note Notes Notes Marke Notas	Pos. No. Index Pos.	N. Cod. Code No. Nr. Code Code Nr N. Cod.	Q.tà Q.ty Q.te M.ge C.ad	DENOMINAZIONE	NAME	DESIGNATION	BESHREIBUNG	DENOMINACION
	34	8H0094010	1	TUBO L= 1380 mm	PIPE L= 1380 mm	TUBE L= 1380 mm	ROHR L= 1380 mm	TUBO L= 1380 mm
	35	8000A5925	1	VALVOLA DI SICUREZZA	SAFETY VALVE	SOUPAPE DE SÉCURITÉ	VENTIL	VÁLVULA DE SEGURIDAD
	36	F000P01420	1	CONVOGLIATORE DESTRO	COVER, RADIATOR, R.H.	OUIE RADIATEUR DROIT	RECHTES LEITBLECH	PROTECTOR RADIADOR DERECHO
	37	FA00P01420	1	CONVOGLIATORE SINISTRO	COVER, RADIATOR, L.H.	OUIE RADIATEUR GAUCHE	LINKES LEITBLECH	DEFLECTOR AIRE IZQUERDO
	38	60ND02508	4	VITE TCEI M6x18	SCREW TCEI M6x18	VIS TCEI M6x18	SCHRAUBE TCEI M6x18	TORNILLO TCEI M6x18
	39	60ND02509	2	VITE TCEI M6x20	SCREW TCEI M6x20	VIS TCEI M6x20	SCHRAUBE TCEI M6x20	TORNILLO TCEI M6x20

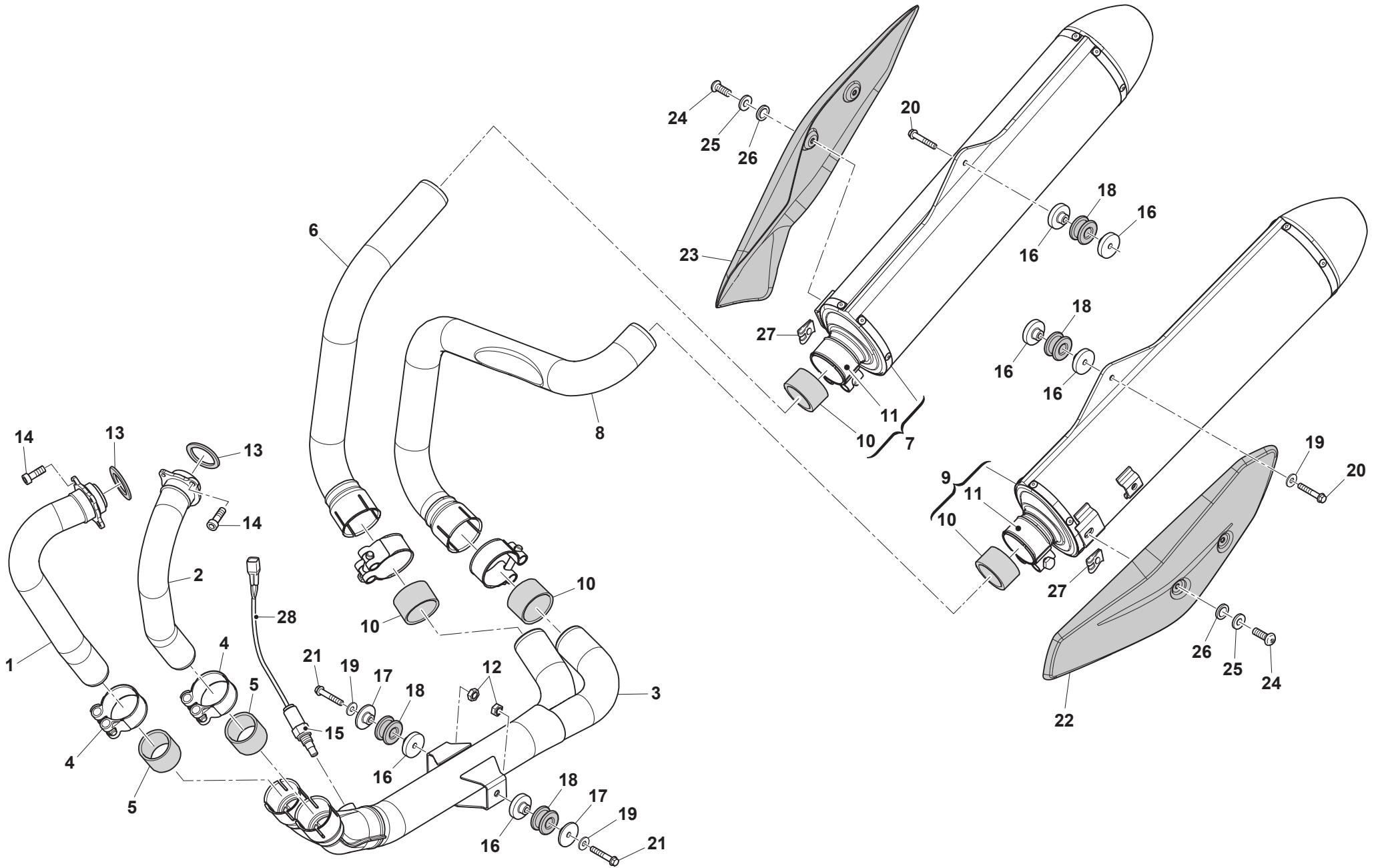





Superdual 2017

**SCARICO - EXHAUST SYSTEM**  
**TUYAU D'ÉCHAPPEMENT - AUSPUFFROHR**  
**TUBO DE ESCAPE**

TAVOLA  
DRAWING  
TABLE  
BILD  
TABLA

24

Note Notes Notes Marke Notas	Pos. No. N. Index Pos.	N. Cod. Code No. Nr. Code Code Nr N. Cod.	Q.tà Q.ty Q.te M.ge C.ad	DENOMINAZIONE	NAME	DESIGNATION	BESHREIBUNG	DENOMINACION
	1	F000P00962	1	COLLETTORE DI SCARICO DESTRO	RIGHT EXHAUST MUFFLER	COLLECTEUR DROITE	KRÜMMER RECHTS	COLECTOR DER.
	2	F000P00963	1	COLLETTORE DI SCARICO SINISTRO	LEFT EXHAUST MUFFLER	COLLECTEUR GAUCHE	KRÜMMER LINKE	COLECTOR IZQ.
	3	F000P00964	1	TUBO DI SCARICO	EXHAUST PIPE	POT D'ÉCHAPPEMENT	AUSPUFFROHR	TUBO DE ESCAPE
	4	8000H2219	2	FASCETTA	CLAMP	COLLIER	SHELLE	ABRAZADERA
	5	8000H1864	2	GUARNIZIONE CILINDRICA COLLETTORI	HEADERS GASKET	JOINT COLLECTEURS	DICHTUNG KRÜMMER	JUNTA COLECTORES
	6	F000P00965	1	TUBO DI SCARICO DESTRO	R.H. EXHAUST PIPE	POT D'ÉCHAPPEMENT DROIT	AUSPUFFROHR RECHTS	TUBO DE ESCAPE DER.
	7	FA00P00468	1	SILENZIATORE DESTRO	R.H. SILENCER	SILENCIEUX DROIT	SCHALLDÄMPFER RECHTS	SILENCIADOR DER.
	8	F000P00966	1	TUBO DI SCARICO SINISTRO	L.H. EXHAUST PIPE	POT D'ÉCHAPPEMENT GAUCHE	AUSPUFFROHR LINKS	TUBO DE ESCAPE IZQ.
	9	F000P00467	1	SILENZIATORE SINISTRO	L.H. SILENCER	SILENCIEUX GAUCHE	SCHALLDÄMPFER LINKS	SILENCIADOR IZQ.
	10	8000H3876	4	GUARNIZIONE CILINDRICA SILENZIATORI	SILENCER GASKET	JOINT SILENCIEUX	DICHTUNG SCHALLDÄMPFER	JUNTA SILENCIADOR
	11	8000H2220	2	FASCETTA	CLAMP	COLLIER	SHELLE	ABRAZADERA
	12	Z00044240	2	DADO AUTOBLOCCANTE M6	SELF-LOCKING NUT M6	ECROU AUTOBLOQUANT M6	SELBSTSICHERNDE MUTTER M6	TUERCA AUTOBLOCANTE M6
	13	8A00A0873	2	GUARNIZIONE	GASKET	JOINT	DICHTUNG	JUNTA
	14	60ND02509	4	VITE TCEI M6x20	SCREW TCEI M6x20	VIS TCEI M6x20	SCHRAUBE TCEI M6x20	TORNILLO TCEI M6x20
	15	F000P01987	1	SONDA LAMBDA	LAMBDA SENSOR	SONDE LAMBDA	LAMBDA-SONDE	SONDA LAMBDA
	16	8C00A7729	6	DISTANZIALE	SPACER	ENTRETOISE	ABSTANDHALTER	DISTANCIADOR
	17	8D00A7729	2	DISTANZIALE	SPACER	ENTRETOISE	ABSTANDHALTER	DISTANCIADOR
	18	800089302	4	SILENT-BLOCK	SILENT-BLOCK	SILENT-BLOCK	SILENT-BLOCK	SILENT-BLOCK
	19	800022271	8	ROSETTA	WASHER	RONDELLE	UNTERLEGSCHLEIBE	ARANDELA
	20	ZE0067545	2	VITE TEF M6x40	FLANGED EXAGON HEAD SCREW M6x40	BOULON DE BRIDE M6x40	SCHRAUBE M6x40	TORNILLO M6x40
	21	ZA0067545	2	VITE TEF M6x35	FLANGED EXAGON HEAD SCREW M6x35	BOULON DE BRIDE M6x35	FLANSCHENSCHRAUBE M6x35	TORNILLO DE REBORDE M6x35
	22	F000A01060	1	PROTEZIONE SILENZIATORE SINISTRO	COVER, L.H. MUFFLER	PROTECTION SILENCIEUX GAUCHE	AUSPUFFROHRSCHUTZ, RECHTS	PROTECCION SILENCIADOR IZQ.
	23	F000A01061	1	PROTEZIONE SILENZIATORE DESTRO	COVER, R.H. MUFFLER	PROTECTION SILENCIEUX DROIT	AUSPUFFROHRSCHUTZ, LINKS	PROTECCION SILENCIADOR DER.
	24	800055703	4	VITE M6x14	BOLT M6x14	VIS M6x14	SCHRAUBE M6x14	TORNILLO M6x14
	25	62N115778	4	ROSETTA	WASHER	RONDELLE	UNTERLEGSCHLEIBE	ARANDELA
	26	800035112	4	RONDELLA ISOLANTE	WASHER	RONDELLE	UNTERLEGSCHLEIBE	ARANDELA
	27	U00046893	4	DADO A GRAFFETTA M6	CLIP NUT M6	ECROU À AGRAFE M6	SICHERUNGSMUTTER M6	TUERCA DE CLIP M6
	28	E000P02164	1	CAVO	CABLE	CÂBLE	KABEL	CABLE

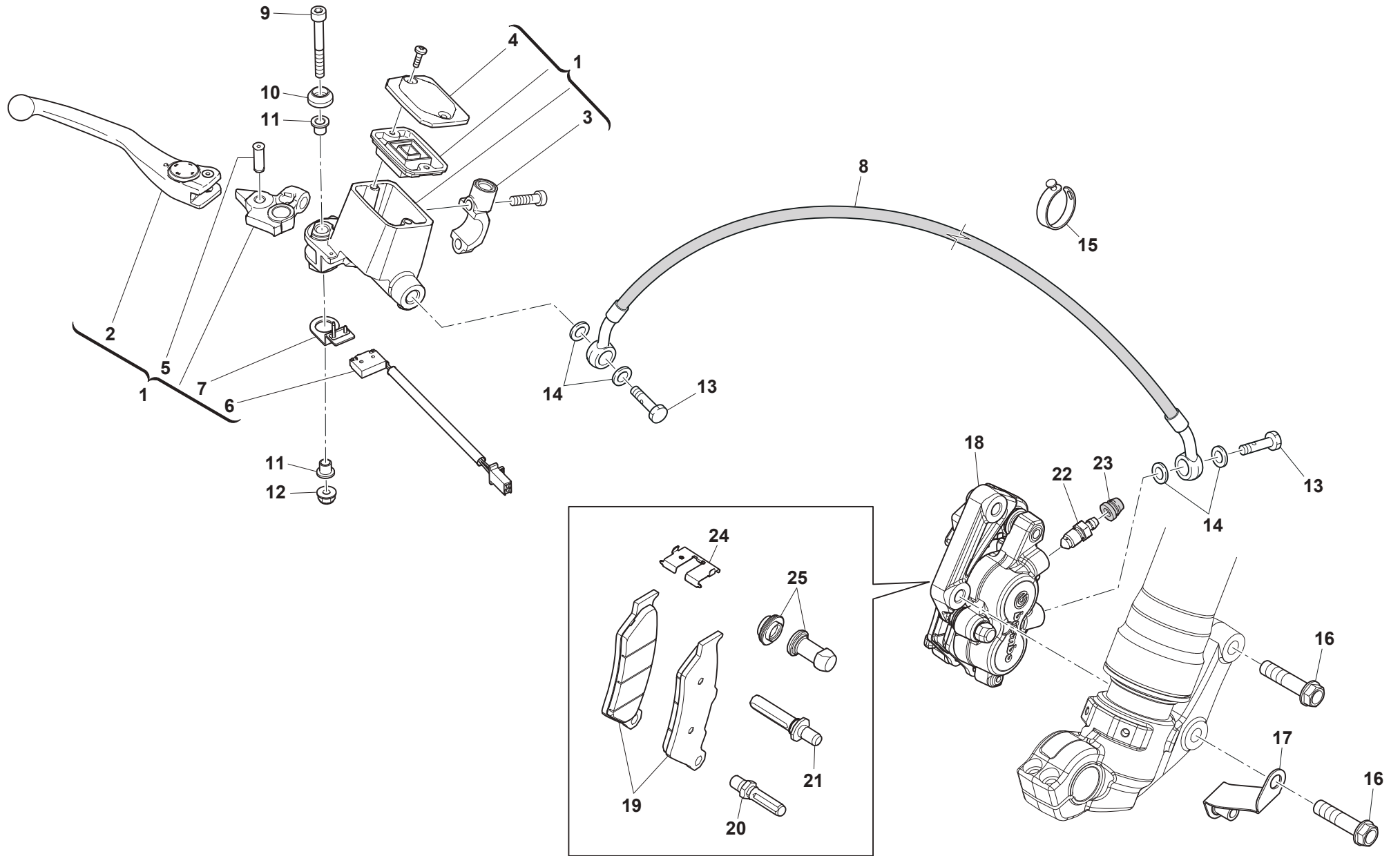



Superdual 2017

**FRENO IDRAULICO ANTERIORE - FRONT HYDRAULIC BRAKE**  
**FREIN HYDRAULIQUE AVANT - VORDERBREMSE**  
**FRENO HIDRAULICO DELANTERO**

TAVOLA  
DRAWING  
TABLE  
BILD  
TABLA

25

Note Notes Marke Notas	Pos. No. N. Index Pos.	N. Cod. Code No. Nr. Code Code Nr N. Cod.	Q.tà Q.ty Q.te M.ge C.ad	DENOMINAZIONE	NAME	DESIGNATION	BESHREIBUNG	DENOMINACION
	1	F000P00942	1	POMPA FRENO ANTERIORE	FRONT MASTER CYLINDER	MAÎTRE-CYLINDRE DE FREIN AVANT	HAUPTBREMSZYLINDER VORNE	BOMBA FRENO DELANTERO
	2	F000P01172	1	LEVA	LEVER	LEVIER	HEBEL	PALANCA
	3	F000P01173	1	CAVALLOTTO	CLAMP	BOULON	BÜGELSCHRAUBE	CABALLETE
	4	F000P01174	1	TAPPO	PLUG	BOUCHON	STOPFEN	TAPON
	5	F000P01175	1	PERNO	PIN	AXE	BOLZEN	EJE
	6	F000P01176	1	MICROINTERRUTTORE CON CABLAGGIO	CABLED MICROSWITCH	MICROINTERRUPTEUR	MIKROSCHALTER	MICROINTERRUPTOR
	7	F000P01177	1	SUPPORTO MICROINTERRUTTORE	MICROSWITCH HOLDER	SUPPORT	HALTERUNG	SOPORTE
	8	F000P00033	1	TUBO FRENO ANTERIORE	FRONT BRAKE HOSE	TUYAU DE FREIN AVANT	ROHR VORDERRADBREMSE	TUBO FRENO DELANTERO
	9	60ND02515	1	VITE TCEI M6X50	SCREW TCEI M6X50	VIS TCEI M6X50	SCHRAUBE TCEI M6X50	TORNILLO TCEI M6X50
	10	F000P00768	1	SCODELLINO	RETAINER	RONDELLE A RESSORT	FEDERTELLER	ASIENTO
	11	8000H0822	2	BUSSOLA	BUSHING	DOUILLE	BUCHSE	CASQUILLO
	12	Z00044240	1	DADO	NUT	ECROU	MUTTER	TUERCA
	13	U00057155	2	VITE RACCORDO TUBO M10X1,00X19	BOLT, BRAKE HOSE M10X1.00X19	VIS FIXATION TUYAU M10X1,00X19	FIXIERSCHRAUBE M10X1,00X19	TORNILLO M10X1,00X19
	14	800021480	4	RONDELLA	WASHER	RONDELLE	UNTERLEGSCHIEBE	ARANDELA
	15	800092247	4	FASCETTA IN GOMMA 62mm	CLAMP, RUBBER 62mm	COLLIER CAOUTCHOUC 62mm	GUMMIBAND 62mm	BANDA DE GOMA 62mm
	16	8H0062797	2	VITE	BOLT	VIS	SCHRAUBE	TORNILLO
	17	F000P01108	1	SUPPORTO SENSORE VELOCITA'	SPEED SENSOR PLATE	PLAQUETTE	PLÄTTCHEN	PLACA
	18	F000A00958	1	PINZA FRENO ANTERIORE	FRONT BRAKE CALLIPER	ETRIER DE FREIN AVANT	BREMSSATTEL VORDERR	PINZA FRENO DELANTERO
	19	F000P01167	1	COPIA PASTIGLIE	PAIR OF BRAKE PADS	PAIRE PLAQUETTES	PAAR BREMSBELÄGE	PAREJA PASTILLAS
	20	8000A0936	1	PERNO COPIGLIA	SPLIT PIN	AXE GOUPILLE	BOLZEN SPLINT	EJE PASADOR
	21	8000A0933	1	PERNO COPIGLIA	SPLIT PIN	AXE GOUPILLE	BOLZEN SPLINT	EJE PASADOR
	22	F000P01170	1	VITE DI SPURGO	BLEEDER SCREW	VIS DE PURGE	ENTLÜFTUNGSSCHRAUBE	TORNILLO DE PURGA
	23	800048432	1	PARAPOLVERE	DUST SEAL	CACHE-POUSSIÈRES	STAUBSCHUTZ	GUARDAPOLVO
	24	F000P01171	1	MOLLA-LAMIERINO	SPRING-PLATE	RESSORT-PLAQUETTE	FEDER-BLECH	MUELLE-CHAPA
	25	800079066	1	CUFFIE	BOOTS	COIFFE	HAUBE	CARCASA

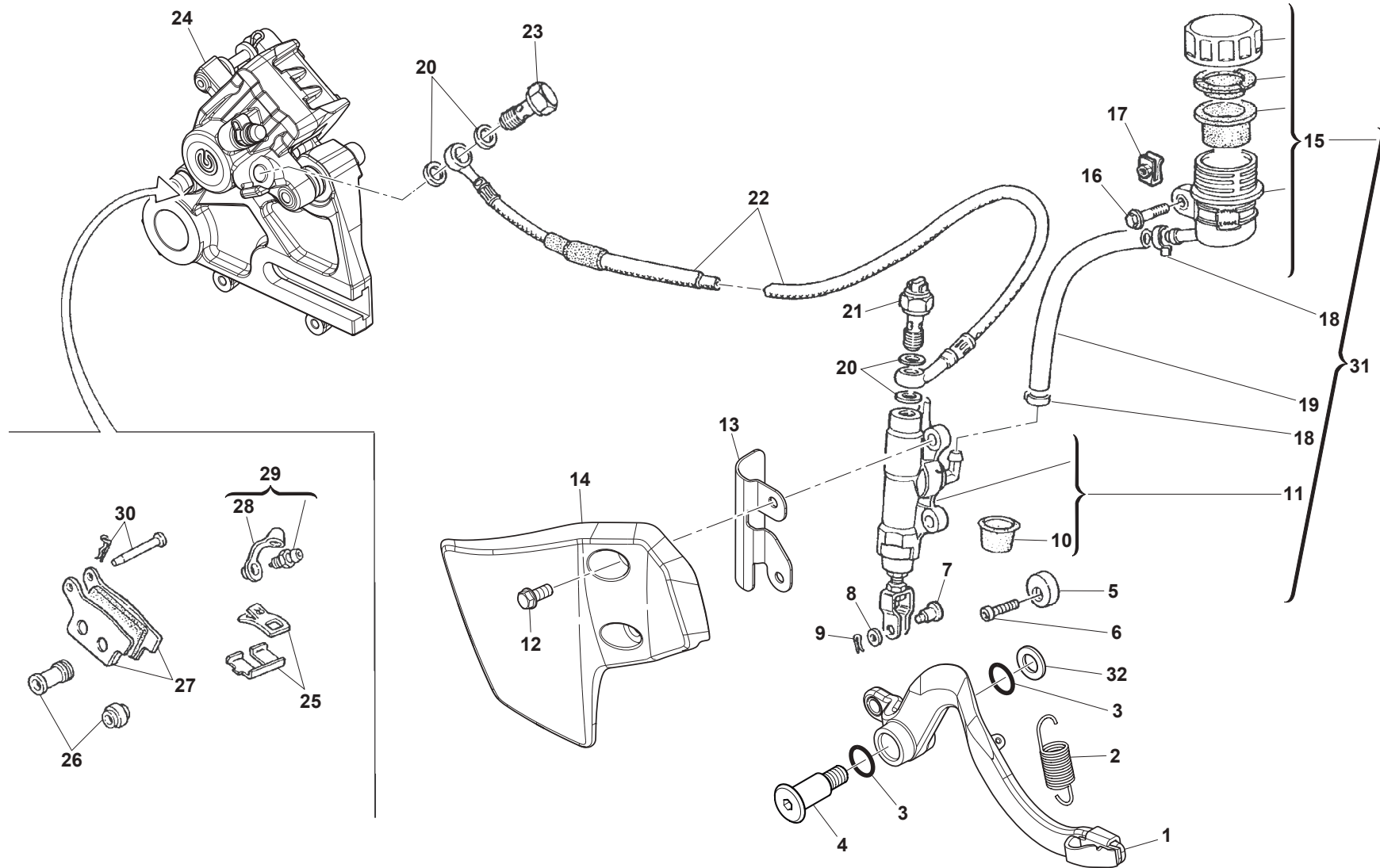

**Superdual 2017**

**FRENO IDRAULICO POSTERIORE - REAR HYDRAULIC BRAKE**  
**FREIN HYDRAULIQUE ARRIERE - HINTERBREMSE**  
**FRENO HIDRAULICO TRASERO**

TAVOLA  
DRAWING  
TABLE  
BILD  
TABLA**26**

Note Notes Notas	Pos. No. Index Pos.	N. Cod. Code No. Nr. Code Code Nr N. Cod.	Q.tà Q.ty Q.te M.ge C.ad	DENOMINAZIONE	NAME	DESIGNATION	BESHREIBUNG	DENOMINACION
	1	F000A01663	1	PEDALE FRENO	PEDAL, BRAKE	PEDALE FREIN	FUSSBREMSPEDAL	PEDAL FRENO
	2	800055903	1	MOLLA PEDALE FRENO	SPRING, BRAKE PEDAL	RESSORT PEDALE FREIN	FEDER, BREMSPEDAL	MUELLE PEDAL FRENO
	3	800022551	2	ANELLO O-RING 2056 14X1,78	O-RING 2056 14X1.78	JOINT TORIQUE 2056 14X1,78	O-RING 2056 14X1,78	JUNTA TORICA 2056 14X1,78
	4	Y00055902	1	VITE TPEI M10X1,25X16	SCREW TPEI M10X1.25X16	VIS TPEI M10X1,25X16	SCHRAUBE TPEI M10X1,25X16	TORNILLO TPEI M10X1,25X16
	5	8A0069125	1	ECCENTRICO PEDALE FRENO	ECCENTRIC, ADJUSTMENT BRAKE PEDAL	EXCENTRIQUE REGLAGE PEDAL FREIN	REGULIEREXZENTIKER BREMSE PEDAL	EXCENTRICO REGULACION PEDAL FRENO
	6	Y00055241	1	VITE TSEI M6X1X14 CH5	SCREW TSEI M6X1X14 CH5	VIS TSEI M6X1X14 CH5	SCHRAUBE TSEI M6X1X14 CH5	TORNILLO TSEI M6X1X14 CH5
	7	800070696	1	PERNO FORCELLINA POMPA 8X20	PIN 8X20	PIVOT 8X20	BOLZEN 8X20	PERNO 8X20
	8	Z00056377	1	RONDELLA 16X8,3X1	WASHER 16X8.3X1	RONDELLE 16X8,3X1	SCHEIBE 16X8,3X1	ARANDELA 16X8,3X1
	9	64ND20068	1	COPIGLIA 18X1,8	SPLIT PIN 18X1.8	GOUPILLE 18X1,8	SPLINT 18X1,8	CLAVIJA 18X1,8
	10	800079075	1	CUFFIA	BOOTS	POUSSIERS	HAUBE	GORRO
	11	800076338	1	POMPA FRENO POSTERIORE	CYLINDER, REAR MASTER	MAITRE CYLINDRE FREIN ARRIERE	HAUPTZYLINDER, HINTEN	BOMBA FRENO TRASERO
	12	8B00A8423	2	VITE TEF M6X12	FLANGED EXAGON HEAD SCREW M6x12	BOULON DE BRIDE M6x12	FLANSCHENSCHRAUBE M6x12	TORNILLO DE REBORDE M6x12
	13	F000P01199	2	PROTEZIONE	PROTECTION	PROTECTION	SCHUTZ	PROTECCIÓN
	14	F000P01122	1	PROTEZIONE POMPA FRENO	MASTER CYLINDER COVER	PROTECTION MAÎTRE-CYLINDRE DE FREIN	SCHUTZ HAUPTBREMSZYLINDER	PROTECCIÓN BOMBA FRENO
	15	800061078	1	VASCHETTA LIQUIDO FRENI POSTERIORE	RESERVOIR, BRAKE FLUID REAR	RESERVOIR LIQUIDE FREINS ARRIERE	BREMSFLUESSIGKEITANK, HINTEN	DEPOSITO LIQUIDO FRENO TRASERO
	16	Z00062727	1	VITE TE M6X1X16 CH8	SCREW TE M6X1X16 CH8	VIS TE M6X1X16 CH8	SCHRAUBE TE M6X1X16 CH8	TORNILLO TE M6X1X16 CH8
	17	U00046893	1	DADO ELASTICO M6X1	CLIP NUT M6X1	JONC M6X1	KLEMME M6X1	PREASIENTO M6X1
	18	800042349	2	FASCETTA	CLAMP	COLLIER	SHELLE	BANDA
	19	8L0066179	1	TUBO IN GOMMA 6,5X10,5X300	HOSE, RUBBER 6.5X10.5X300	TUYAU EN CAOUTCHOUC 6,5X10,5X300	GUMMISCHLAUCH 6,5X10,5X300	TUBO DE GOMA 6,5X10,5X300
	20	800021480	4	RONDELLA	WASHER	RONDELLE	UNTERLEGSCHIEBE	ARANDELA
	21	800094849	1	INTERRUTTORE STOP POSTERIORE	REAR STOP SWITCH	INTERRUPTEUR STOP	STOPSCHALTER	INTERRUPTOR STOP TRASERO
	22	8000A0665	1	TUBO FRENO POSTERIORE	REAR BRAKE TUBE	TUYAU DU FREIN AR.	HINTERE BREMSLEITUNG	TUBO FRENO TRASERO
	23	U00057155	1	VITE RACCORDO TUBO M10X1,00X19	BOLT, BRAKE HOSE M10X1.00X19	VIS FIXATION TUYAU M10X1,00X19	FIXIERSCHRAUBE M10X1,00X19	TORNILLO FIJACION MANGUERA M10X1,00X19
	24	F000A00315	1	PINZA FRENO POSTERIORE	CALIPER, REAR BRAKE	ETRIER FREIN ARRIERE	HINTEN BREMSSELTEL	PINZA FRENO TRASERA
	25	800085932	1	MOLLETTE PASTIGLIE FRENO	SUPPORT, PAD	RESSORT PLAQUETTE FREIN	FEDER, BREMSSEHEIBE	MUELLE PASTILLAS
	26	800079066	1	SERIE SILENTBLOCK PINZA FRENO	CAPS OVERHAUL SET	GROUPE REVISION CAPOUCHONS	GUMMIUBERARBAITUNGSZAZ	GRUPO REVISION GORRO
	27	8000A9231	1	COPPIA PASTIGLIE FRENO POSTERIORE	PADS SET, REAR BRAKE	JEU PLAQUETTES FREIN ARRIERE	HINTERBREMSBELAEGESATZ	JUEGO PASTILLAS FRENO TRASERO
	28	800053259	1	CAPPUCCIO VITE SPURGO	CAP, BLEEDER SCREW	CAPUCHON VIS RENIFLARD	ENTLUEFTUNGSKAPPE	CAPUCHON TORNILLO PURGA PINZA
	29	8000A0931	1	VITE SPURGO PINZA FRENO	BLEED SCREW KIT	VIS VIDANGE ETRIER FREIN	SCHRAUBE, BREMSSELTEL ABLASS	TORNILLO PURGA PINZA FRENO
	30	8000A0933	1	GRUPPO REVISIONE PERNI PASTIGLIE	PAD PINS OVERHAUL SET	GROUPE REVISION PIVOTS PLAQUETTE	BREMSBELAEGEN EBERHOLUNGSGRUPPE	GRUPO REVISION PERNO PASTILLAS FRENO
	31	8A0076026	1	POMPA FRENO POSTERIORE	CYLINDER, REAR MASTER	MAITRE CYLINDRE FREIN ARRIERE	HAUPTZYLINDER, HINTEN	BOMBA FRENO TRASERO
	32	8000H1412	1	ROSETTA	WASHER	RONDELLE	UNTERLEGSCHIEBE	ARANDELA

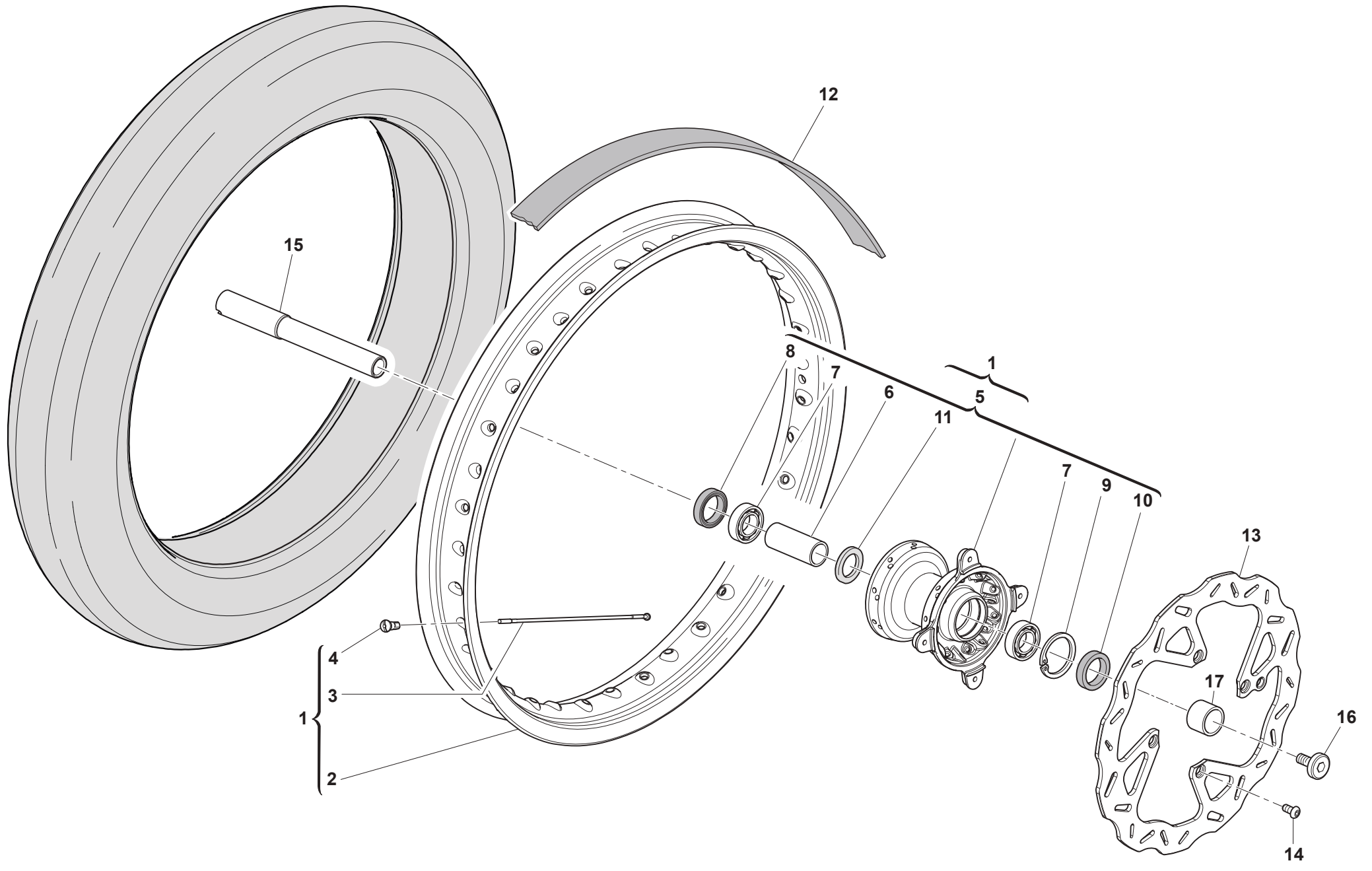



Superdual 2017

**RUOTA ANTERIORE - FRONT WHEEL**  
**ROUE AVANT - VORTERRAD**  
**RUEDA DELANTERA**

TAVOLA  
DRAWING  
TABLE  
BILD  
TABLA

27

Note Notes Notes Marke Notas	Pos. No. Index Pos.	N. Cod. Code No. Nr. Code Code Nr N. Cod.	Q.tà Q.ty Q.te M.ge C.ad	DENOMINAZIONE	NAME	DESIGNATION	BESHREIBUNG	DENOMINACION
	1	FA00A00054	1	RUOTA ANTERIORE SENZA PNEUMATICO	FRONT WHEEL WITHOUT TYRE	ROUE AVANT SANS PNEU	VORDERRAD OHNE TYRE	RUEDA DELANTERA SIN NEUMÁTICO
	2	FOA0P00055	1	CERCHIO RUOTA ANT. 2.5"X19"	FRONT WHEEL RIM 2.5"X19"	JANTE ROUE AVANT 2.5"X19"	FELGE VORDERRAD 2.5"X19"	LLANTA RUEDA DEL. 2.5"X19"
	3	F000P00056	36	RAGGIO	SPOKE	BRAS	SPEICHE	RADIO
	4	69N429004	36	NIPPLO	NIPPLE	NIPPLE	NIPPEL	NIPLE
	5	FA00A00091	1	MOZZO RUOTA ANTERIORE	FRONT WHEEL HUB	MOYEU	NABE	CUBO
	6	F000P00120	1	DISTANZIALE INTERNO	INTERNAL SPACER	ENTRETOISE INTÉRIEUR	INTERNER ABSTANDHALTER	DISTANCIADOR INTERNO
	7	800084938	2	CUSCINETTO D25-D42-L9	BEARING	ROULEMENT	LAGER	COJINETE
	8	8000H6187	1	ANELLO D42-D28-SP7	RING D42-D28-THK7	BAGUE D42-D28-SP7	RING D42-D28-SP7	ANILLO D42-D28-SP7
	9	66N021270	1	ANELLO DI FERMO	RETAINING RING	BAGUE D'ARRET	SICHERUNGSRING	ANILLO DE RETENCION
	10	800022966	1	ANELLO DI TENUTA D42-D32-SP7	SEALING RING D42-D32-THK7	BAGUE D'ETANCHEITE D42-D32-SP7	DICHTUNGSRING D42-D32-SP7	ANILLO DE ESTANQUEIDAD D42-D32-SP7
	11	F000P00121	1	ANELLO DI SUPPORTO	SUPPORT RING	BAGUE DE SUPPORT	HALTERUNG RING	ANILLO DE SOPORTE
	12	8000130777	1	PROTEZIONE CAMERA D'ARIA	AIR TUBE PROTECTION	VAINES DE PROTECTION	HULLE	VAINA DE PROTECCION
	13	F000P00957	1	DISCO FRENO ANTERIORE	FRONT BRAKE DISC	DISQUE DE FREIN	BREMSSCHEIBE	DISCO FRENO
	14	YA0092876	4	VITE M8X16	BOLT M8X16	VIS M8X16	SCHRAUBE M8X16	TORNILLO M8X16
	15	FA00P00058	1	PERNO RUOTA ANTERIORE	FRONT WHEEL AXLE	PIVOT DE ROUE AVANT	FRONT RADASCHE	EJE RUEDA DELANTERO
	16	800096933	1	VITE M20	SCREW M20	VIS M20	SCHRAUBE M20	TORNILLO M20
	17	8A0096930	1	DISTANZIALE	SPACER	ENTRETOISE	ABSTANDHALTER	DISTANCIADOR

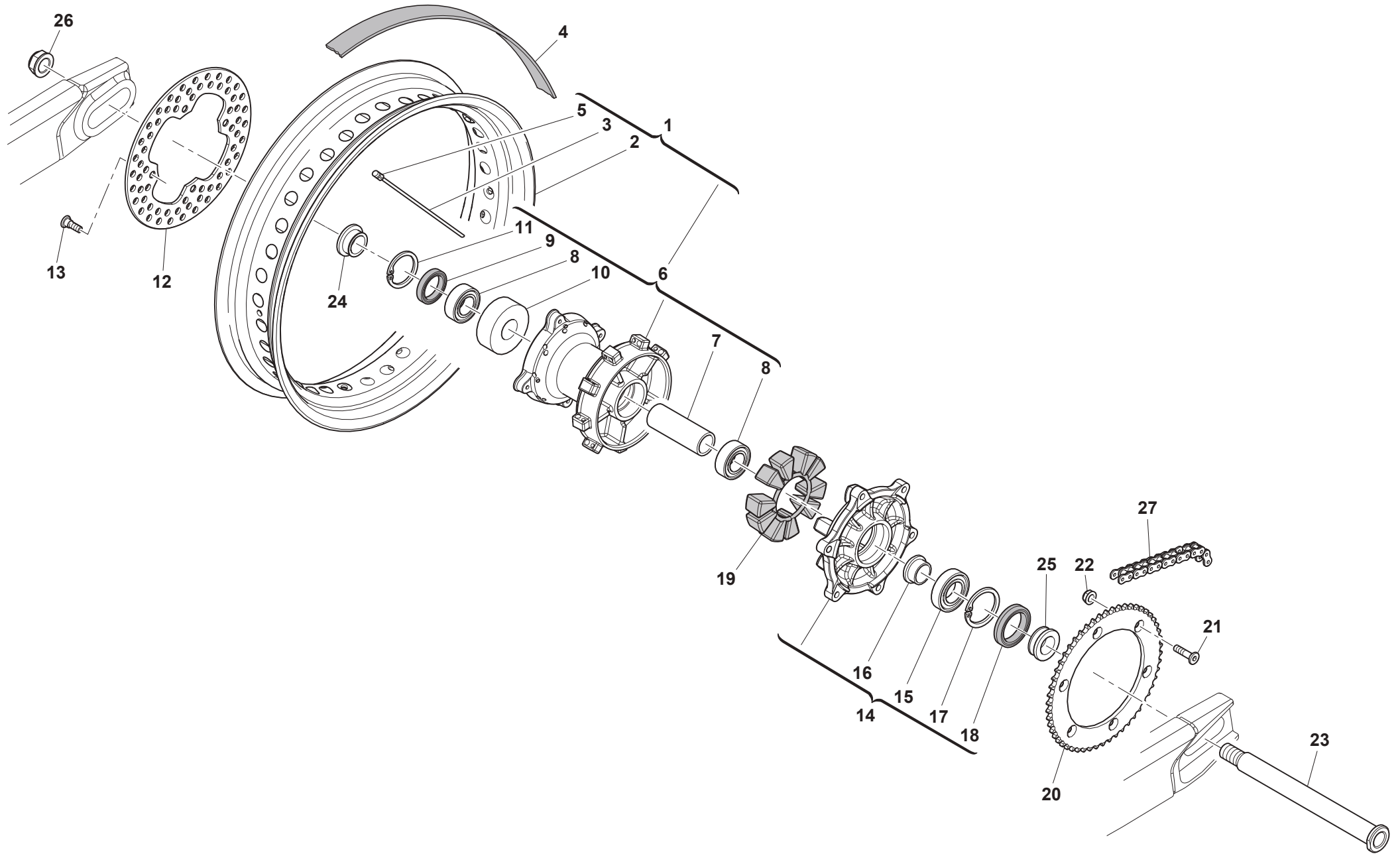



**Superdual 2017**

**RUOTA POSTERIORE - REAR WHEEL**  
**ROUE ARRIERE - HINTERRAD**  
**RUEDA TRASERA**

TAVOLA  
DRAWING  
TABLE  
BILD  
TABLA

**28**

Note Notes Marke Marka Notas	Pos. No. N. Index Pos.	N. Cod. Code No. Nr. Code Code Nr N. Cod.	Q.tà Q.ty Q.te M.ge C.ad	DENOMINAZIONE	NAME	DESIGNATION	BESHREIBUNG	DENOMINACION
	1	F000A00060	1	RUOTA POSTERIORE SENZA PNEUMATICO	REAR WHEEL WITHOUT TYRE	ROUE ARRIÈRE SANS PNEU	HINTERRAD OHNE TYRE	RUEDA TRASERA SIN NEUMÁTICO
	2	F000P00061	1	CERCHIO RUOTA POST. 3,5"x17"	REAR WHEEL RIM 3,5"x17"	JANTE ROUE ARRIÈRE 3,5"x17"	FELGE HINTERRAD 3,5"x17"	LLANTA RUEDA TRAS. 3,5"x17"
	3	8000H1725	18	RAGGIO	SPOKE	BRAS	SPEICHE	RADIO
	3	F000P00063	18	RAGGIO	SPOKE	BRAS	SPEICHE	RADIO
	4	8B0082879	1	PROTEZIONE CAMERA D'ARIA	AIR TUBE PROTECTION	VAINE DE PROTECTION	HULLE	VAINA DE PROTECCION
	5	69N429005	36	NIPPLIO	NIPPLE	NIPPLE	NIPPEL	NIPLE
	6	F000A00997	1	MOZZO RUOTA POSTERIORE	REAR WHEEL HUB	MOYEU	NABE	CUBO
	7	F000P00998	1	DISTANZIALE INTERNO	INTERNAL SPACER	ENTRETOISE INTÉRIEUR	INTERNER ABSTANDHALTER	DISTANCIADOR INTERNO
	8	8B0026846	2	CUSCINETTO A SFERE 25x47x16	BALL BEARING 25x47x16	ROULEMENT À BILLES 25x47x16	KUGELLAGER 25x47x16	COJINETE DE BOLAS 25x47x16
	9	800089572	1	ANELLO 47x32x7	RING 47x32x7	BAGUE 47x32x7	RING 47x32x7	ANILLO 47x32x7
	10	F000P00121	1	PORTA DISTANZIALE	SPACER HOLDER	SUPPORT ENTRETOISE	HALTERUNG ABSTANDHALTER	SOPORTE DISTANCIADOR
	11	66N021272	1	ANELLO ELASTICO	CIRCLIP	CIRCLIP	SPRENGRING	ANILLO ELASTICO
	12	800088887	1	DISCO FRENO POSTERIORE	REAR BRAKE DISC	DISQUE DE FREIN	BREMSSCHEIBE	DISCO FRENO
	13	800055878	4	VITE M6x11	BOLT M6x11	VIS M6x11	SCHRAUBE M6x11	TORNILLO M6x11
	14	F000A01001	1	FLANGIA	FLANGE	BRIDE	FLANSCH	BRIDA
	15	F000P00999	1	CUSCINETTO 55x30x13	BEARING 55x30x13	ROULEMENT 55x30x13	LAGER 55x30x13	COJINETE 55x30x13
	16	F000P01000	1	DISTANZIALE	SPACER	ENTRETOISE	ABSTANDHALTER	DISTANCIADOR
	17	66N021276	1	ANELLO ELASTICO	CIRCLIP	CIRCLIP	SPRENGRING	ANILLO ELASTICO
	18	F000P01098	1	ANELLO PARAPOLVERE	DUST SEAL	CACHE-POUSSIÈRES	STAUBSCHUTZ	GUARDAPOLVO
	19	800082075	1	PARASTRAPPI	ANTI-VIBRATION BUFFERS	AMORTISSEUR DE COUPLE	REIßSCHUTZ	ACOPLAMIENTO ELÁSTICO
	20	8G0085291	1	CORONA DENTATA Z=38	CHAIN SPROCKET T=38	COURONNE DENTÉE Z=38	ZAHNKRANZ Z=38	CORONA DENTADA Z=38
	21	8000H0158	6	VITE SPECIALE TSEI M8x28	M8x28SPECIAL BOLT	VIS SPÉCIAUX M8x28	SPEZIALSCHRAUBE M8x28	TORNILLO ESPECIAL M8x28
	22	Y00043928	6	DADO FRENATO M8	SELF-LOCKING NUT M8	ECROU AUTOBLOQUANT M8	SELBSTSICHERNDE MUTTER M8	TUERCA AUTOBLOCANTE M8
	23	F000P00066	1	PERNO RUOTA POSTERIORE	REAR WHEEL AXLE	PIVOT DE ROUE ARRIÈRE	RADASCHE OHNE	EJE RUEDA TRASERA
	24	800096938	1	DISTANZIALE ESTERNO	SPACER	ENTRETOISE	ABSTANDHALTER	DISTANCIADOR
	25	F000P01099	1	DISTANZIALE ESTERNO	SPACER	ENTRETOISE	ABSTANDHALTER	DISTANCIADOR
	26	Y00093072	1	DADO M20	NUT M20	ECROU M20	MUTTER M20	TUERCA M20
	27	FA00P01133	1	CATENA 110 PASSI				

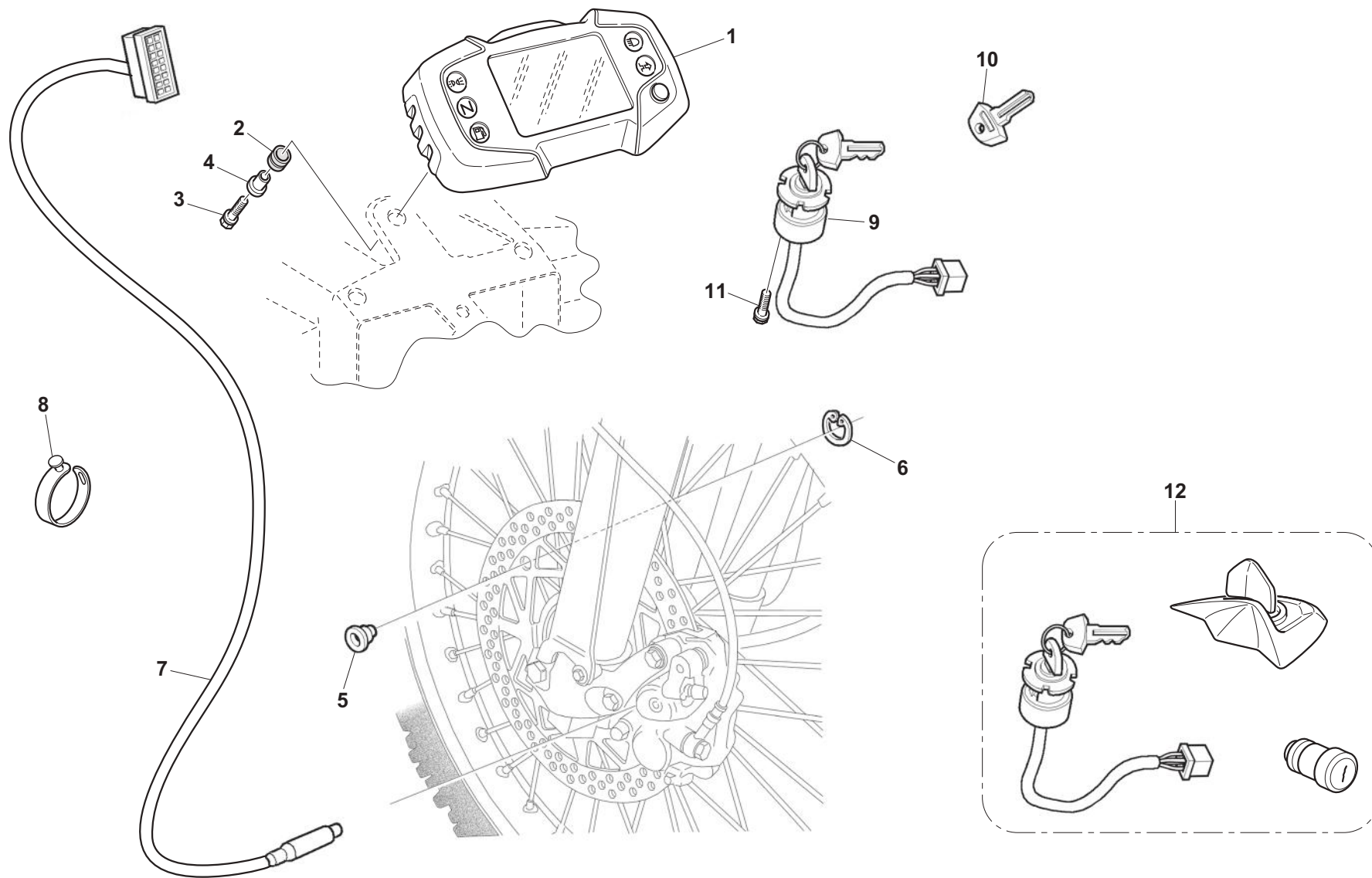



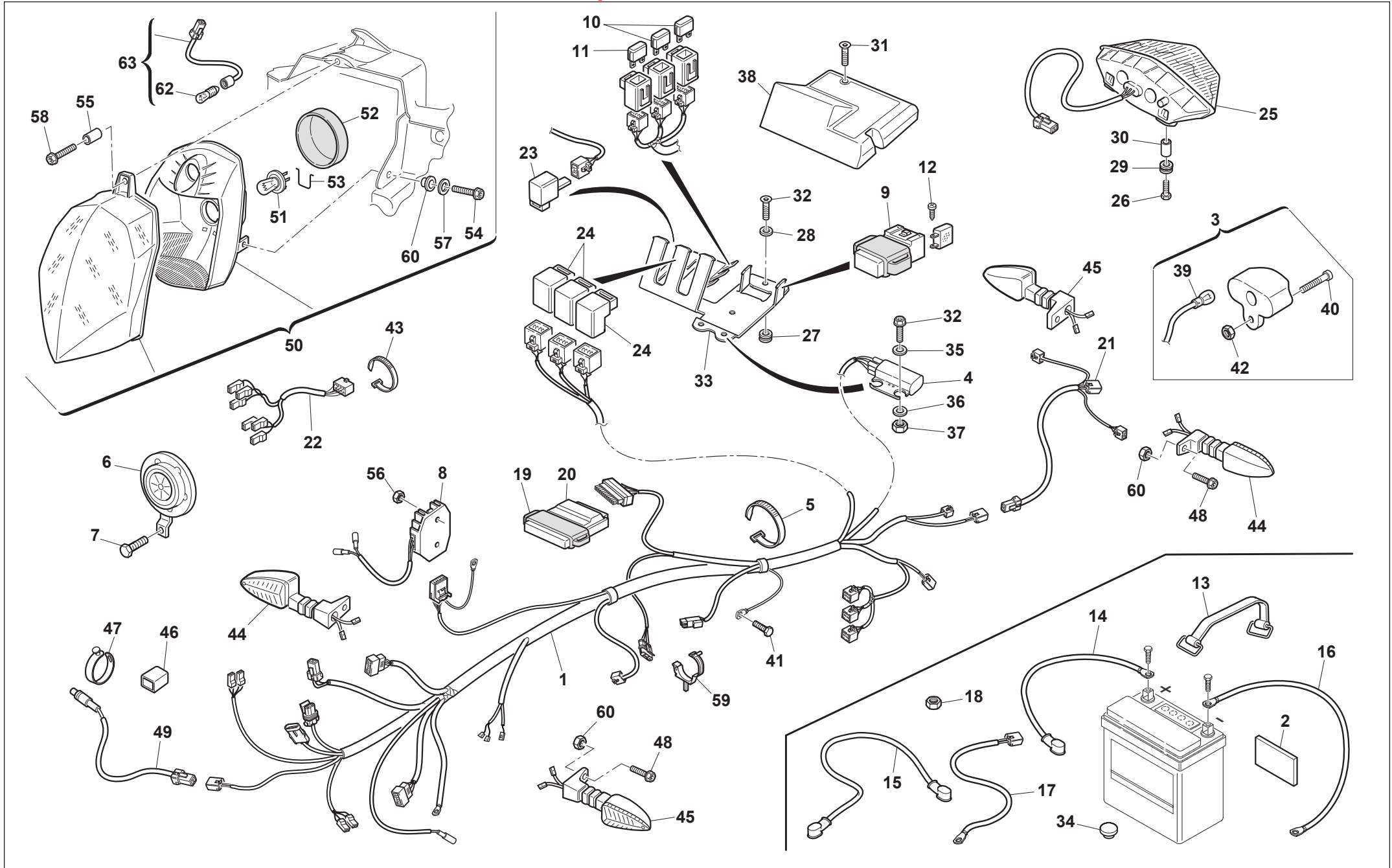



**GRUPPO CAVI, PARTI ELETTRICHE - MAIN WIRING HARNESS, ELECTRICAL PARTS  
CABLES PRINCIPAL, PARTIES ELECTRIQUES - KABEL, ELEKTRISCHE KOMPONENTE  
GRUPO PRINCIPAL CABLES, PARTES ELECTRICAS**

Note Notes Notes Marke Notas	Pos. No. N. Index Pos.	N. Cod. Code No. Nr. Code Code Nr N. Cod.	Q.tà Q.ty Q.te M.ge C.ad	DENOMINAZIONE	NAME	DESIGNATION	BESHREIBUNG	DENOMINACION
	1	E000P00953	1	IMPIANTO ELETTRICO	ELECTRIC SYSTEM	ÉLECTRIQUE INSTALLATION	ELEKTRIK PLANT	EQUIPO ELECTRICO
	2	800057673	1	SPESSORE ELASTICO	ELASTIC SPACER	ENTRETOISE ELASTIQUE	DISTANZSTÜCK	ESPEJOR ELÁSTICO
	3	8000A0212	1	FANALE ILLUMINAZIONE TARGA	LAMP, LICENSE PLATE	FEU ECLARAGE PLAQUE IMMATRICULATION	KENNZEICHENLEUCHTE	FARO LUZ MATRICULA
	4	8000A6756	1	SENSORE DI CADUTA	SENSOR, LEAN ANGLE	CAPTEUR SECURITE CHUTE	NEIGUNG ABTASTER	SENSOR INCLINACION
	5	800056444	10	FASCETTA 188 mm	CLAMP 188 mm	COLLIER 188 mm	SHELLE 188 mm	ABRAZADERA 188 mm
	5	8A005444	9	FASCETTA 188 mm	CLAMP 188 mm	COLLIER 188 mm	SHELLE 188 mm	ABRAZADERA 188 mm
	6	E000A01753	1	AVVISATORE ACUSTICO	HORN	AVERTISSEUR SONORE	HUPE	AVISADOR ACÚSTICO
	7	Z00062726	1	VITE TEF M6X1,00X10 CH8	SCREW TEF M6X1.00X10 CH8	VIS TEF M6X1,00X10 CH8	SCHRAUBE TEF M6X1,00X10 CH8	TORNILLO TEF M6X1,00X10 CH8
	8	8000A6768	1	REGOLATORE DI TENSIONE	VOLTAGE RECTIFIER	RÉGULATEUR DE TENSION	SPANNUNGSREGLER	REGULADOR DE TENSIÓN
	9	8000H0809	1	TELERUTTORE AVVIAMENTO	REMOTE SWITCH	TELERUPTEUR	FERNSHALTER	TELERRUPTOR
	10	8F0095647	2	FUSIBILE 15A	FUSE 15A	FUSIBLE 15A	SICHERUNG 15A	FUSIBLE 15A
	11	8G0095647	1	FUSIBILE 20A	FUSE 20A	FUSIBLE 20A	SICHERUNG 20A	FUSIBLE 20A
	12	ZS0067545	3	VITE TEF M6X1 CH8	SCREW TEF M6X1 CH8	VIS TEF M6X1 CH8	SCHRAUBE TEF M6X1 CH8	TORNILLO TEF M6X CH8
	13	800077612	1	CINGHIA BATTERIA	BAND, BATTERY	SANGLE BATTERIE	GURTEL, BATTERIE	CORREA BATERIA
	14	8000H1868	1	CAVO POLO POSITIVO	WIRE, BATTERY PLUS LEAD	CABLE POSITIF	PLUSPOLKABEL	CABLE POSITIVO
	15	8000H1869	1	CAVO MOTORINO AVVIAMENTO	WIRE STARTER MOTOR	CORDON MOTEUR DEMARRAGE	VERKABELUNG STARTERMOTOR	CABLEADO MOTOR ARRANQUE
	16	8000H1871	1	CAVETTO DI MASSA	CABLE	CABLE	KABEL	CABLE
	17	8000H1870	1	CAVO MASSA BATTERIA	BATTERY GROUNDING CABLE	CABLE MASSE BATTERIE	BATTERIEMASSEKABEL	CABLE TIERRA BATERIA
	18	Z00061313	1	DADO M6X1 H6 CH10	NUT M6X1 H6 CH10	ECROU M6X1 H6 CH10	MUTTER M6X1 H6 CH10	TUERCA M6X1 H6 CH10
	19	F000P00132	1	SUPPORTO CENTRALINA INIEZIONE	BRACKET ENGINE CONTROL UNIT	SUPPORT UNITE' CONTROLE INJECTION	HALTER, EINSPRITZUNG ZENTRALANLAGE	SOPORTE CENTRAL INYECCION
	20	E000P00131	1	CENTRALINA ELETTRONICA DA PROGRAMMARE	ELECTRONIC CONTROL UNIT TO BE PROGRAMMED	BOÎTIER ÉLECTRONIQUE A PROGRAMMER	STEUERELEKTRONIK ZU PROGRAMMIEREN	CENTRALITA ELECTRÓNICA PARA PROGRAMAR
	21	8000H1176	1	CAVO FANALE POSTERIORE	CABLE	CABLE	KABEL	CABLE
	22	8000A6094	1	CAVO FANALE ANTERIORE	CABLE	CABLE	KABEL	CABLE
	23	8000H1082	1	INTERMITTENZA LAMPEGGIATORI	FLASHER RELAY	RELAIS CLIGNOTANTS	BLINKERRELAIS	RELE INTERMITENTES
	24	8000A6749	3	RELE'	RELAY	RELAIS	RELAIS	RELE
	25	8000H1418	1	FANALE POSTERIORE	TAIL LIGHT	FEUX ARRIÈRE	HINTERLEUCHTE	FARO TRASERO
	26	Z00062727	2	VITE TE M6X1X16 CH8	SCREW TE M6X1X16 CH8	VIS TE M6X1X16 CH8	SCHRAUBE TE M6X1X16 CH8	TORNILLO TE M6X1X16 CH8
	27	8000H2374	3	SILENTBLOCK	DAMPER	SILENTBLOC	SCHWINGUNGSDAEMPFER	CASQUILLO ELASTICO
	28	800067245	3	DISTANZIALE	SPACER	ENTRETOISE	DISTANZSTÜCK	SEPARADOR
	29	800095128	2	GOMMINO	SILENT-BLOCK	ANTIVIBRATION	SCHWINGUNGS DÄMPFER	ANTI-VIBRADOR
	30	8000H1735	2	BOCCOLA FLANGIATA	BUSH WITH COLLAR	DOUILLE BRIDEE	GEFLANSCHBUCHSE	CASQUILLO REBORDEADO
	31	Z00065535	3	VITE TCEI M5X0,8X14	SCREW	VIS	SCHRAUBE	TORNILLO
	32	60ND01030	2	VITE TE M4X0,7X25	SCREW TE M4X0.7X25	VIS TE M4X0,7X25	SCHRAUBE TE M4X0,7X25	TORNILLO TE M4X0,7X25

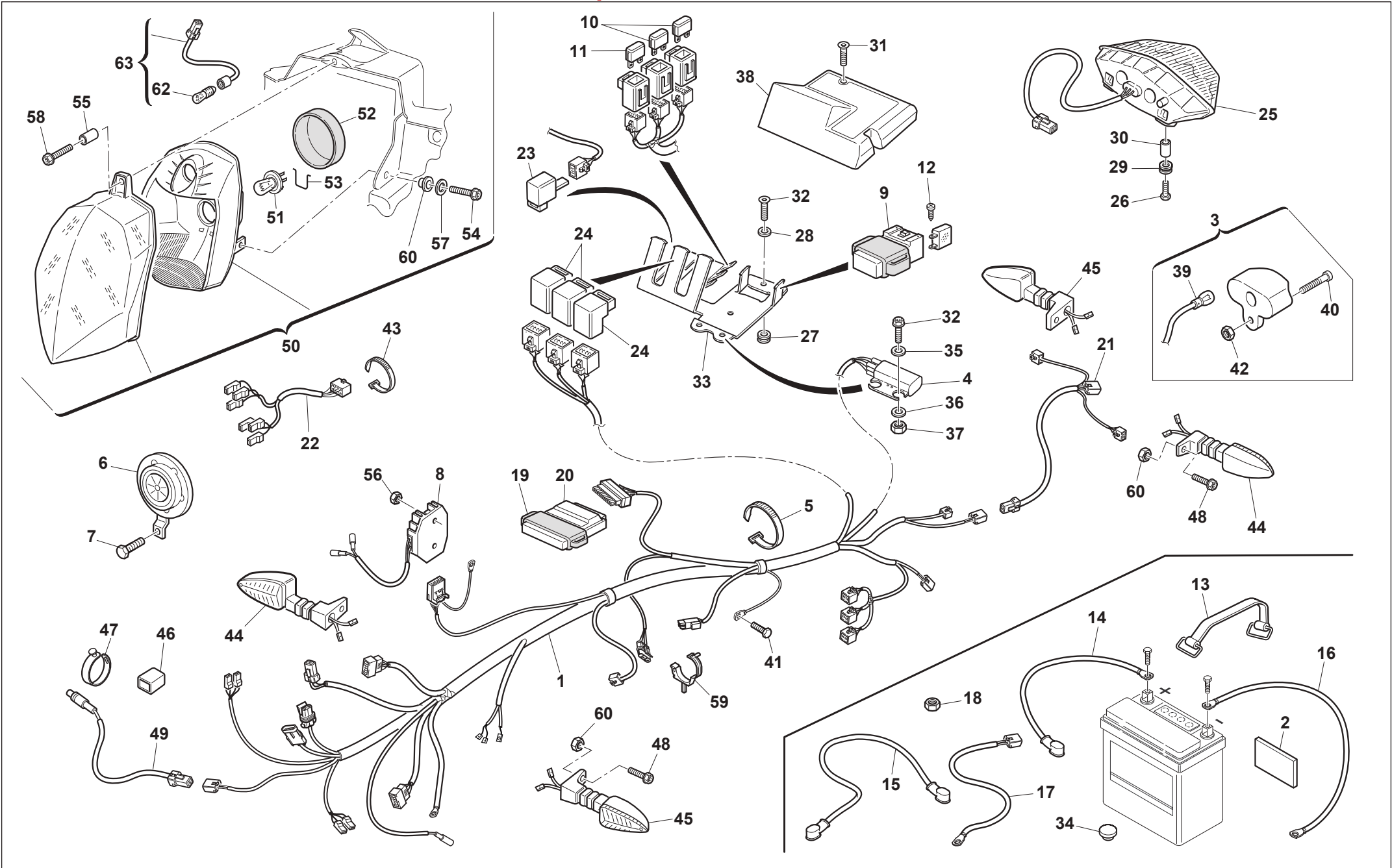



Superdual 2017

GRUPPO CAVI, PARTI ELETTRICHE - MAIN WIRING HARNESS, ELECTRICAL PARTS - CABLES PRINCIPAL, PARTIES ELECTRIQUES - KABEL, ELEKTRISCHE KOMPONENTE - GRUPO PRINCIPAL CABLES, PARTES ELECTRICAS

TAVOLA DRAWING TABLE BILD TABLA

30

Table with 9 columns: Note/Notes/Notas, Pos. No./N. Index/Pos., N. Cod./Code No./Nr. Code/Code Nr./N. Cod., Q.tà/Q. ty/Q. te/M.ge/C.ad, DENOMINAZIONE, NAME, DESIGNATION, BESHREIBUNG, DENOMINACION. Rows 33-64 listing various electrical components like connectors, washers, nuts, covers, lamps, screws, switches, and lights.

**INFORMAZIONI IMPORTANTI**

Pressione pneumatici a freddo

Solo guidatore	ANT.	Kg./cm <sup>2</sup>	psi
	POST.	Kg./cm <sup>2</sup>	psi
Guidat. e passegg.	ANT.	Kg./cm <sup>2</sup>	psi
	POST.	Kg./cm <sup>2</sup>	psi

**REGOLAZIONE CATENA**



4

3

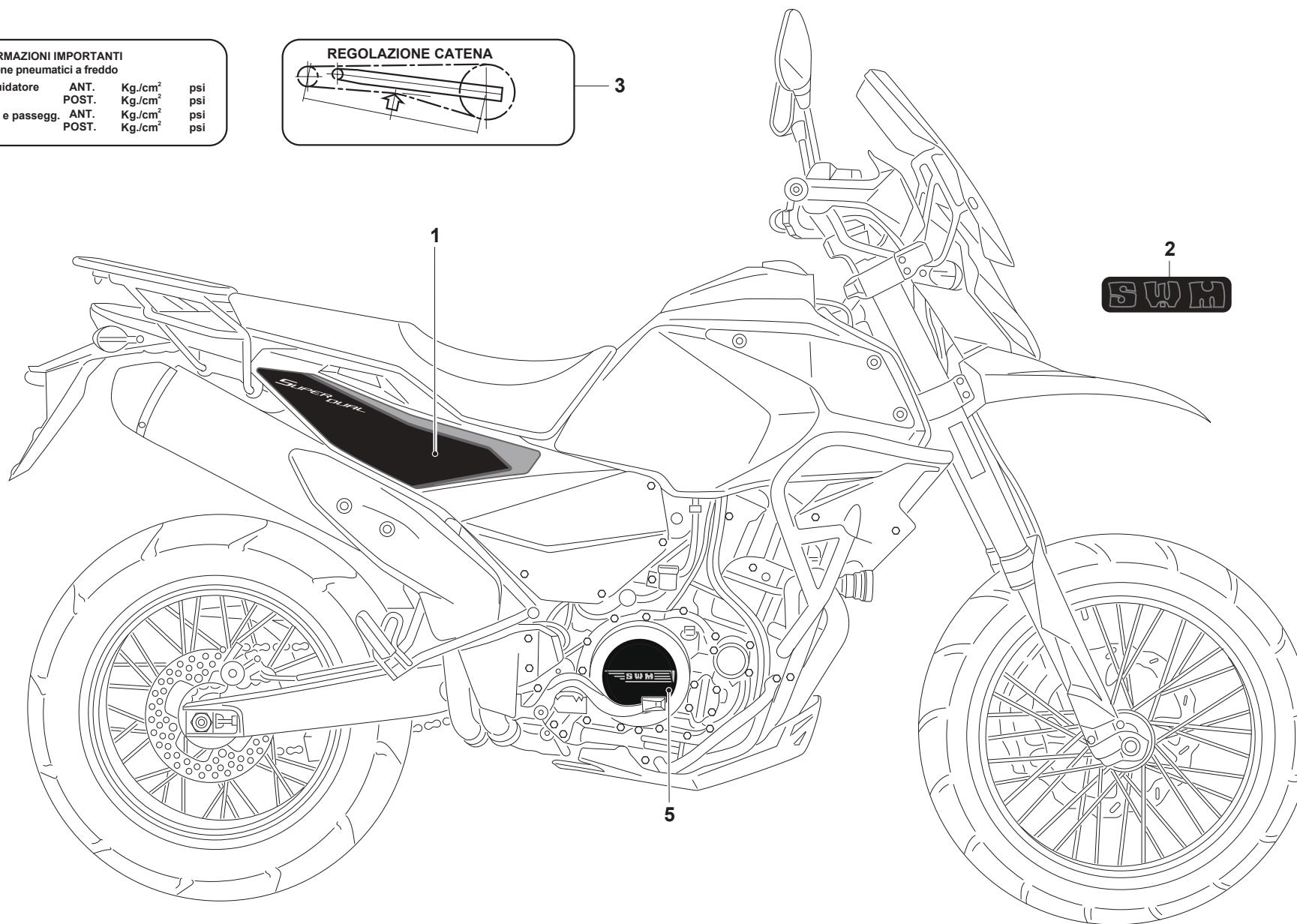





**DECALCOMANIE - TRANSFER  
DACLALCOMANIE - ABZIEHBILD  
CALCOMANIA**

Note Notes Marke Notas	Pos. No. Index Pos.	N. Cod. Code No. Nr. Code Code Nr N. Cod.	Q.tà Q.ty M.ge C.ad	DENOMINAZIONE	NAME	DESIGNATION	BESHREIBUNG	DENOMINACION
	1	F000P00951	1	STICKER FIANCHETTO DESTRO	R.H. PANEL STICKER	EMBLEME COUVERCLE CADRE DROIT	EMBLEM, SEITENABDECKUNG RECHTS	EMBLEMA CUBIERTA LATERAL DERECHA
	1	F000P00949	1	STICKER FIANCHETTO SINISTRO	L.H. PANEL STICKER	EMBLEME COUVERCLE CADRE GAUCHE	EMBLEM, SEITENABDECKUNG LINKS	EMBLEMA CUBIERTA LATERAL IZQUERDA
	2	F000P01095	1	STICKER CUPOLINO	HEADLAMP FAIRING-STICKER	EMBLEME	EMBLEM	EMBLEMA
	3	800077872	1	ETICHETTA RACCOMANDAZIONI CATENA	LABEL DRIVE CHAIN	ETIQUETTE RECOMMANDATION CHAINE	WARNSCHILD, KETTE EMPFEHLUNG	ETIQUETA RECOMENDACION CADENA
	4	800077871	1	ETICHETTA RACCOMANDAZIONI PNEUMATICI	LABEL, TIRE, INFORMATION	ETIQUETTE RECOMMANDATION PNEU	WARNSCHILD REIFEN EMPFEHLUNG	ETIQUETA RECOMENDACION NEUMATICOS
	5	M000P00225	1	STICKER	STICKER	STICKER	STICKER	ETIQUETA

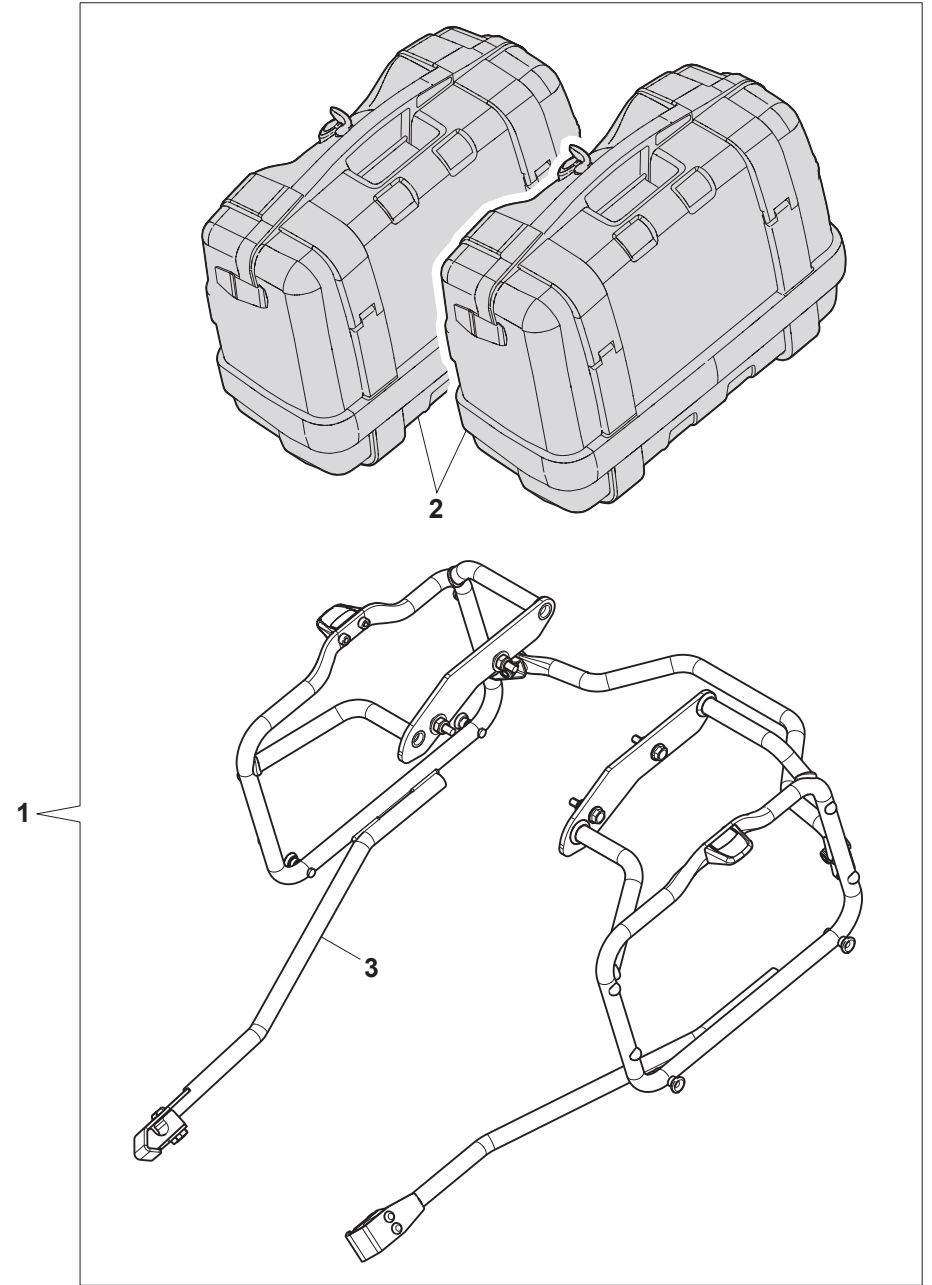
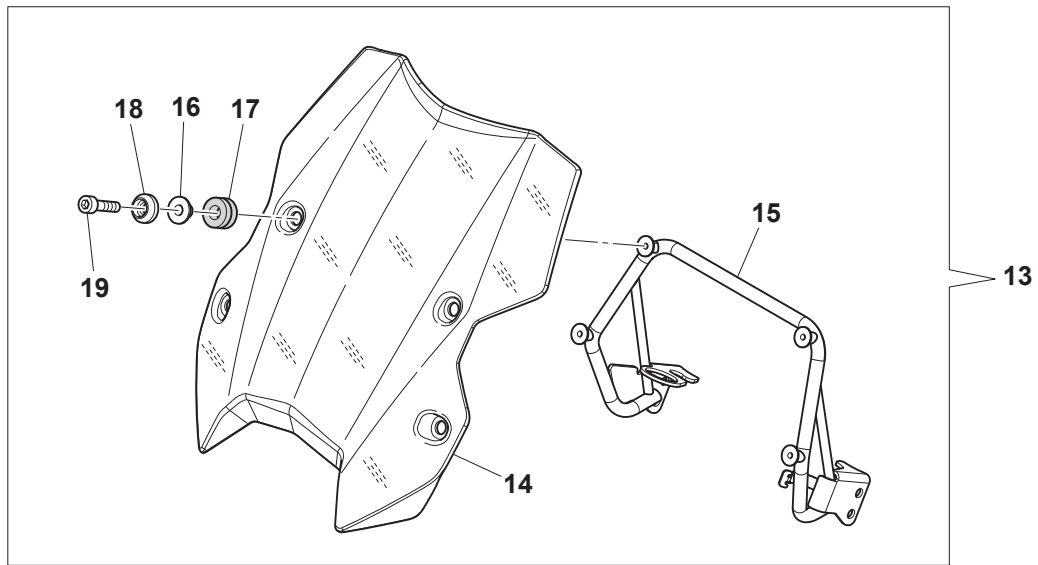
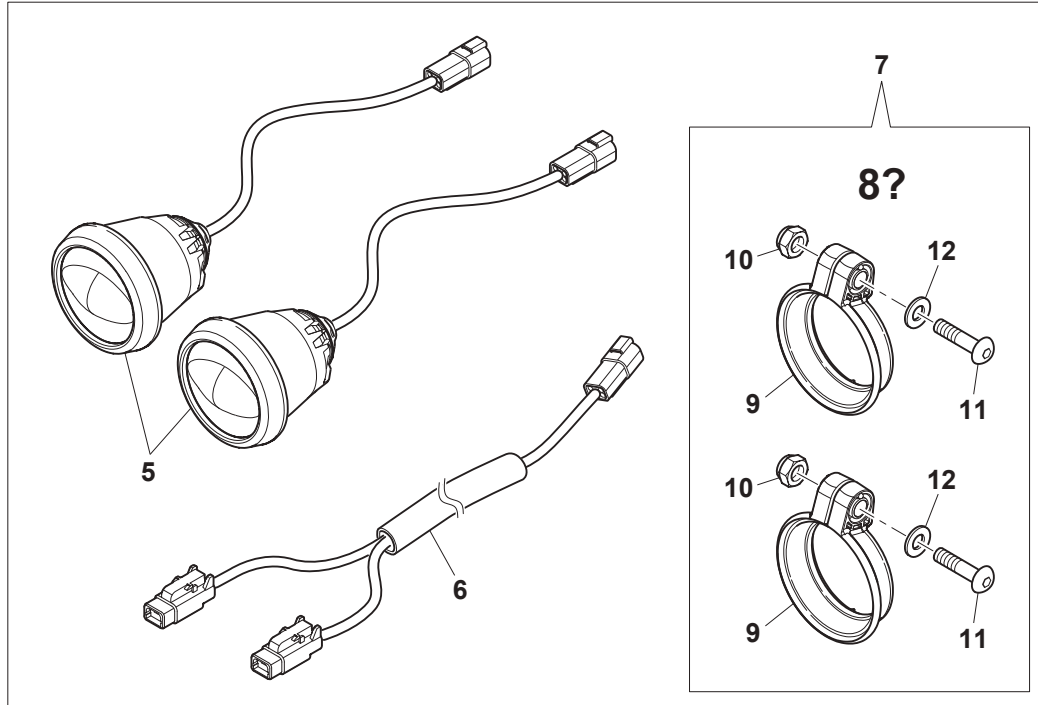



Superdual 2017

**ACCESSORI - ACCESSORIES**  
**ACCESSOIRES - ACCESSOIRE**  
**ACCESORIO**

TAVOLA  
DRAWING  
TABLE  
BILD  
TABLA

32

Note Notes Notes Marke Notas	Pos. No. Index Pos.	N. Cod. Code No. Nr. Code Code Nr N. Cod.	Q.tà Q.ty Q.te M.ge C.ad	DENOMINAZIONE	NAME	DESIGNATION	BESHREIBUNG	DENOMINACION
	1	A000A01056	1	KIT GT PACK	GT PACK KIT	KIT GT PACK	KIT GT PACK	KIT GT PACK
	2	A000A01953	1	COPPIA DI VALIGE	PAIR OF SUITCASES	VALISES	KOFFER	MALETAS
	3	A000A01954	1	TELAIO PORTA VALIGE	SOUITCASES FRAME	CHÂSSIS	RAHMEN	CHASIS
	4	A000A01057	1	KIT FARETTI	FOGLIGHT KIT	KIT ANTI BROUILLARD	KIT NEBELSCHEINWERFER	KIT LUCE ANTINEBLA
	5	A000P01749	2	FENDINEBBIA	FOGLIGHT	ANTI BROUILLARD	NEBELSCHEINWERFER	LUCE ANTINEBLA
	6	A000P01750	1	CAVO FENDINEBBIA	FOGLIGHT CABLE	CÂBLE	KABEL	CABLE
	7	A000P02419	1	KIT FISSAGGIO FARETTI	FOGLIGHT FIXIONG KIT	KIT DE FIXATION	KIT HALTERUNG	KIT DE FIJACIÓN
	8	A000P01419	1	PULSANTE	BUTTON	BOUTON	SCHALTER	INTERRUPTOR
	9	A000P01550	2	SUPPORTO	SUPPORT	SUPPORT	HALTERUNG	SOPORTE
	10	Z00091033	2	DADO AUTOBLOCCANTE M4	SELF-LOCKING NUT M4	ECROU AUTOBLOQUANT M4	SELBSTSICHERNDE MUTTER M4	TUERCA AUTOBLOCANTE M4
	11	F000P02226	2	VITE TBEI M4x22	BOLT TBEI M4x22	VIS TBEI M4x22	SCHRAUBE TBEI M4x22	TORNILLO TBEI M4x22
	12	F000P02227	4	RONDELLA	WASHER	RONDELLE	UNTERLEGSSCHEIBE	ARANDELA
	13	A000A00930	1	KIT PARABREZZA	WINDSHIELD KIT	KIT PARE BRISE	WINDSCHUTZSCHEI KIT	KIT PARABRISA
	14	A000P01054	1	PARABREZZA	WINDSHIELD	PARE BRISE	WINDSCHUTZSCHEI	PARABRISA
	15	A000P01055	1	SUPPORTO PARABREZZA	WINDSHIELD SUPPORT	SUPPORT PARE BRISE	HALTERUNG	SOPORTE PARABRISA
	16	8000B2799	4	DISTANZIALE	SPACER	ENTRETOISE	ABSTANDHALTER	DISTANCIADOR
	17	800041862	4	ANTIVIBRANTE	SILENT-BLOCK	ANTIVIBRATION	SCHWINGUNGSDAMFER	ANTIVIBRADOR
	18	F000P00768	4	RONDELLA CONICA	CONIC SPACER	RONDELLE CONIQUE	UNTERLEGSSCHEIBE	ARANDELA CONICA
	19	60ND02509	4	VITE TCEI M6x20	SCREW TCEI M6x20	VIS TCEI M6x20	SCHRAUBE TCEI M6x20	TORNILLO TCEI M6x20